

**freud.**

---

# **Circular Saw Blades Kružne testere**

Catalogue 2018/19 - Katalog 2018/19



## Circular saw blades for INDUSTRIAL MACHINES - Choose the right tool

Kružne testere za INDUSTRIJSKE MAŠINE - Izaberite odgovarajući alat .....Str. 10

## Circular saw blades for PORTABLE MACHINES - Choose the right tool

Kružne testere za RUČNE CIRKULARE - Izaberite odgovarajući alat.....Str. 11

## Teeth shape varieties as applied to saw blades

Vrste zuba po tipovima testera.....Str. 12 - 13

## Thin kerf multiripping saw blades with rakers

Tanke testere za višelisne cirkulare sa čistačima  
LM01.....Str. 14

## Reduced kerf multiripping saw blades with rakers

Testere smanjene debljine za višelisne cirkulare sa čistačima  
LM02.....Str. 15  
LM03.....Str. 16

## Multiripping saw blades with rakers

Testere za višelisne cirkulare sa čistačima  
LM04.....Str. 17  
LM05.....Str. 18

## Increased kerf multiripping saw blades

Testere povećane debljine za višelisne cirkulare  
LM06.....Str. 19  
LM10 **novo**.....Str. 22

## Shoulder thick kerf saw blades with rakers

Debele testere sa čistačima  
LM07.....Str. 20

## Ultra-thin kerf multiripping saw blades

Izuzetno tanke (krajnje) testere za višelisne cirkulare  
LM08.....Str. 21

## Universal saw blades for cutting solid wood

Univerzalne testere za rezanje masiva  
LU1A.....Str. 23  
LU1B.....Str. 24  
LU1C.....Str. 25  
LU1D.....Str. 26  
LU1E.....Str. 27  
LU1F.....Str. 28  
LU1G.....Str. 29  
LU1H.....Str. 30  
LU1I.....Str. 31  
LU1L.....Str. 32  
LG1C.....Str. 45

## Universal saw blades to cut wood and composite materials

Univerzalne testere za rezanje drveta i kompozitnih materijala  
LU2A.....Str. 33  
LU2B.....Str. 34  
LU2C.....Str. 35  
LU2D.....Str. 36  
LU2E.....Str. 37  
LU2F.....Str. 38  
LG2A.....Str. 46  
LG2B.....Str. 47  
LG2C.....Str. 48

## Universal saw blades to cut bilaminated panels

Univerzalne testere za rezanje obostrano oplemenjenih pločastih materijala  
LU3A.....Str. 39  
LU3B.....Str. 40  
LU3C.....Str. 41  
LU3D.....Str. 42  
LU3E.....Str. 43  
LU3F.....Str. 44  
LG3D.....Str. 49

## Reference table of saw blades for panel sizing machines

Referentna tabela testera za formatizere .....Str. 50 - 57

## Panel sizing saw blades

Testere za rezanje pločastih materijala  
LSB X.....Str. 58 - 59  
LSB.....Str. 60 - 62  
LSC.....Str. 63

## Conical scoring saw blades

Predrezači sa konusnim zubom  
LI25M.....Str. 64 - 65

## Adjustable scoring saw blades

Podesivi predrezači  
LI16M.....Str. 66

## Postforming scoring saw blades

Predrezači za radne ploče  
LI27M.....Str. 67

## Flat tooth scoring saw blades

Predrezači sa ravnim zubom  
LI20M.....Str. 67  
LI17M.....Str. 68

## Bevelled tooth scoring saw blades

Predrezači sa kosim zubom  
LI22MD - LI22MS.....Str. 68  
LI13MD - LI13MS.....Str. 69

## End trim unit for panels with banded edges

Testere za odsecanje kant trake  
LI14MD - LI14MS.....Str. 69

## Saw blades for freud hogging units

Testere za FREUD drobljače  
LT16MD - LT16MS.....Str. 70  
LT18MD - LT18MS.....Str. 71

## Saw blades for hogging units

Testere za drobljače  
LT12MD - LT12MS.....Str. 70  
LT14MD - LT14MS.....Str. 71

## Saw blades for Leuco hogging units

Testere za LEUCO drobljače  
LT20MD - LT20MS.....Str. 72

## Hogging units with SR06M interchangeable inserts

Drobljači sa SR06M zamjenjivim pločicama  
TR16MD - TR16MS.....Str. 73

## Mounting sleeves for hogging units

Nosači za drobljače  
MT01M.....Str. 73

## Saw blades to cut plastic materials

Testere za rezanje plastičnih materijala  
LU4A.....Str. 74  
LU4B.....Str. 75

## Saw blades to cut solid surfaces

Testere za rezanje radnih ploča  
LU4D.....Str. 76

## Saw blades to cut non-ferrous metals

Testere za rezanje obojenih metala  
LU5A.....Str. 77  
LU5C.....Str. 79  
LU5E.....Str. 81

## Saw blades to cut non-ferrous metals and PVC

Testere za rezanje obojenih metala i PVC-a  
LU5B.....Str. 78  
LU5D.....Str. 80  
LU5F **novo**.....Str. 82

## Saw blades to cut mild steel

Testere za rezanje crnih metala i čelika  
LU6A.....Str. 83

## SAW BLADES FOR PORTABLE MACHINES

### TESTERE ZA RUČNE CIRKULARE

## Saw blades for cutting solid wood

Testere za rezanje masiva  
LP20M.....Str. 84  
LP30M.....Str. 85  
LP40M.....Str. 86

## Saw blades for hardwood and softwood

Testere za tvrdo i meko drvo

LP60M .....Str. 87 - 88

## Saw blades for on-site jobs

Testere za rezanje na terenu

LP70M .....Str. 87

## Saw blades to cut non-ferrous metals

Testere za rezanje aluminijuma i obojenih metala

LP40M .....Str. 89

LP80M .....Str. 89

## Saw blades to cut ferrous metals

Testere za rezanje gvožđa i crnih metala

LP90M .....Str. 90

## Saw blades to cut bilaminated panels

Testere za rezanje obostrano oplemenjenih pločastih materijala

LP67M **ново** .....Str. 88

## Saw blades to cut aluminum and bilaminated panels

Testere za rezanje aluminijuma i obostrano oplemenjenih pločastih materijala

LP85M .....Str. 90

## Saw blades to cut multi-material

Testere za rezanje više materijala

LP91M .....Str. 91

## Standard reduction rings for saw blades

Standardni redukcionni prstenovi za testere

BL15M - BL20M.....Pag. 91

## Optional workings - Standard keyways

Opcioni radovi - Standardni tasteri

OPT06.....Str. 92

## Optional workings - Special keyways

Opcioni radovi - Standardni tasteri

OPT07.....Str. 92

## Optional workings - Special reboring

Opcioni radovi - Proširenje otvora

OPT08.....Str. 92

## Optional workings - Safety pin holes for saw blades

Opcioni radovi - Sigurnosni otvori

OPTFO.....Str. 92

## Tips for the correct use of a saw blade

Saveti za ispravno korišćenje testere.....Str. 93 - 99

## Explanation of symbols and abbreviations

Pojašnjenje simbola i skraćenica ..... Str. 100

# freud.

---

## Circular Saw Blades Kružne testere

Catalogue 2018/19 - Katalog 2018/19

GATECH  
[www.freud.rs](http://www.freud.rs)

The firm reserves the rights to partially modify this catalogue without any obligations to third parties.  
Kompanija zadržava pravo delimične izmene kataloga bez obaveza prema trećim stranama.



# Your productive partner Vaš pouzdan partner

Premium quality industrial tools for superior efficiency

Industrijski alati vrhunskog kvaliteta za maksimalnu efikasnost



### A wide range of top performing products

An extensive variety of precise and high-tech tools.

- Circular Saw Blades: the biggest manufacturer of high quality saw blades worldwide.
- Cutterheads and Brazed Cutters: freud sets the highest standard in the wood industry and window tooling.
- Knives, Spare parts and Accessories: in-house production of all Carbide inserts, unique in the world.
- Drilling, Routing & CNC Tools: a complete range for all applications.

### Široka gama vrhunskih proizvoda

Veliki izbor preciznih i modernih alata.

- Kružne testere: najveći proizvođač visokokvalitetnih testera na svetu.
- Glodala sa izmenjivim i lemljenim pločicama: FREUD postavlja najviše standarde u drvoju i industriji prozora.
- Pločice, rezervni delovi i dodaci: FREUD je jedinstven u svetu po proizvodnji svih karbidnih elemenata u okviru kuće.
- Alati za CNC: kompletna gama za sve aplikacije.



A wide range of industrial cutting tools.  
Široka gama industrijskih alata za rezanje.

**GATECH**  
[www.freud.rs](http://www.freud.rs)

### High quality solutions for your applications

Engineering competence and manufacturing know-how.

- Customized-to-Order: products to match special production needs.
- Enhanced technologies: Silver I.C.E., Perma-SHIELD, EXrim, ISOprofil, High Speed ISOprofil and Split-Edge.

### Visokokvalitetna rešenja za Vaše aplikacije

Stručnost u konstruisanju i proizvodnji.

- Specifični zahtevi: proizvodi po specijalnim zahtevima proizvodnje.
- Napredne tehnologije: Silver I.C.E, Perma-SHIELD, EXrim, ISOprofil, High Speed ISOprofil i Split-Edge.



Advanced engineering and technology.  
Napredno projektovanje i tehnologija.

### Global services wherever you are

A belief in "think global and act local".

- Our worldwide subsidiaries and partners in over 90 countries ensure an extensive service and distribution network.
- Since 2009 freud is part of Bosch group, leveraging the global network of the world leading technology supplier.

### Globalna usluga gde god da se nalazite

Verovanje u "misli globalno, radi lokalno".

- Naši agenti i partneri širom sveta u preko 90 zemalja osiguravaju dobru uslugu i distribuciju.
- Od 2009. godine FREUD je deo BOSCH grupe, čineći globalnu mrežu vodećeg svetskog dobavljača tehnoloških proizvoda.



Worldwide presence.  
Prisutnost širom sveta.



# Advanced technology Napredna tehnologija

Innovative solutions to maximize  
your investments

Inovativna rešenja  
za maksimizaciju Vaših investicija

### In-house Tungsten Carbide (HW) production

- TiCo Carbide is a specially formulated, highly compact Titanium Cobalt Carbide, engineered and manufactured in-house by Freud.
- Special HW grades are mixed based on application needs and checked according to strict quality criteria.
- Special tooth geometries are developed for perfect cuts.

### Proizvodnja Tungsten Karbida (HW) "u kući"

- TiCo Karbid je specijalna formula, visokokompaktna verzija Titanijum Kobalt Karbida, stvorena i proizvedena "u kući" od strane FREUD-a.
- Specijalne klase HW mešaju se po potrebi i proveravaju po striktnim kriterijumima kvaliteta.
- Specijalna geometrija zuba razvijena je da bi se omogućio savršen rez.

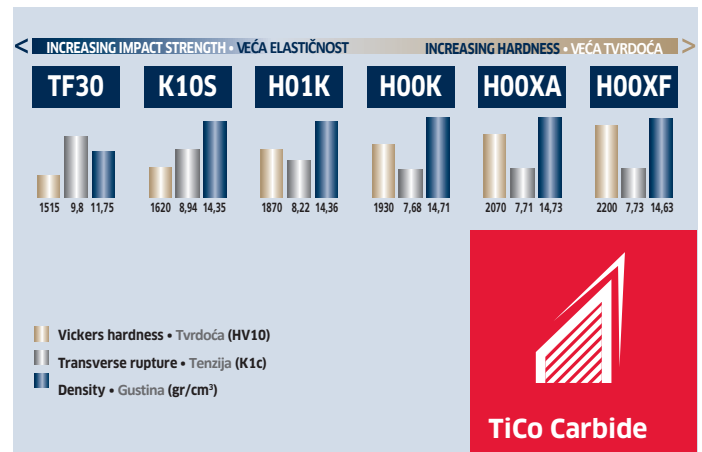

Overview of different standard HW grades.  
Tablica različitih standardnih HW klasa.

**GATECH**  
[www.freud.rs](http://www.freud.rs)

### Multiple sharpenings: super square tooth design

- Tip thickness 30% greater than standard tips.
- Up to 25 sharpenings to extend the product life-time.

### Višetraka oštrenja: superkvadratni zub

- Debljina vrha 30% veća od standardne.
- Do 25 oštrenja i znatno duži radni vek alata.

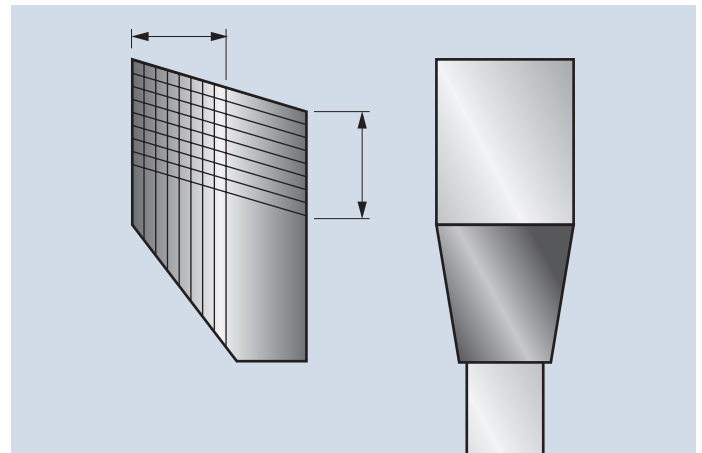

Supersquare tooth.  
Superkvadratni zub.

### Maximum durability: tri-metal shock resistant brazing

- Freud special tri-metal alloy consists of copper wrapped between layers of silver.
- This solution allows the Carbide tips to withstand extreme impact, for maximum durability.

### Maksimalna izdržljivost: trimetalni izuzetno otporan sloj

- FREUD-ov specijalni trimetalni sloj sastoji se od bakra između dva sloja srebra.
- Ovakvo rešenje omogućava da Karbidni vrhovi mogu da podnesu ekstremne uslove i imaju maksimalnu trajnost.

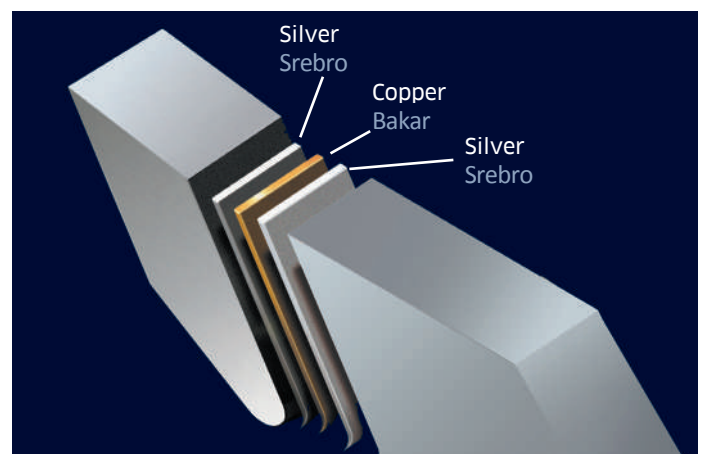

Tri-metal brazing.  
Trimetalni sloj.

# Superior finishing Superioran završni rez

A flawless result with no re-work  
Besprekoran rezultat od prvog do  
poslednjeg reza



### Reduced friction: Silver I.C.E. Coating

- A high performing and anticorrosive coating to maintain the blade temperature low during the working process.
- The non-stick feature improves chip ejection and notably reduces resin build-up, significantly reducing friction and extending the life time of the blade.

### Smanjeno trenje: Silver I.C.E. zaštitni sloj

- Antikorozivni zaštitni sloj visokih performansi održava temperaturu testere nižom tokom rada.
- Nelepljivi sloj poboljšava radne karakteristike smanjenjem lepljenja piljevine, značajnim smanjenjem trenja i produžavanjem veka trajanja sečiva.



Silver I.C.E. coating.  
Silver I.C.E. zaštitni sloj

GATECH  
[www.freud.rs](http://www.freud.rs)

### Improved precision: Anti-vibration slots for the perfect finishing

- Body slots laser cut with freud innovative technology.
- Also available with thermoplastic polyurethane filling, that considerably reduces vibration and minimizes noise.

### Poboljšana preciznost: Antivibracioni prorezi za savršen rez

- Prorezi na telu testere laserski su usečeni uz pomoć inovativne FREUD-ove tehnologije.
- Prorezi su popunjeni termoplastičnim poliuretanskim materijalom, koji značajno smanjuje vibracije vibracije i buku.

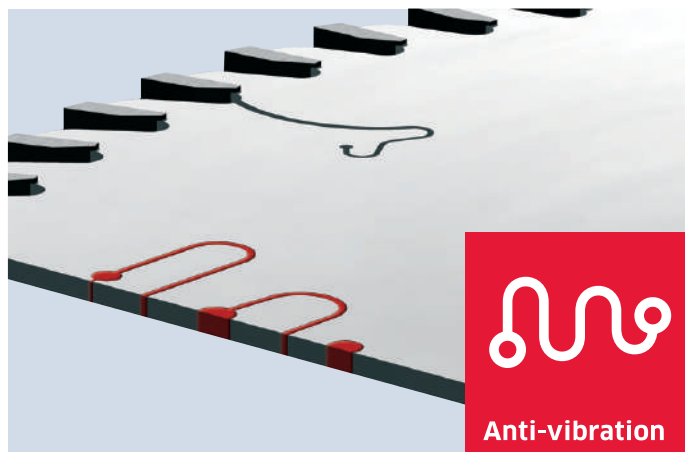

Section view of the antivibration slots.  
Presek antivibracionih proseka

### No blade distortion: laser cut steel, tensioning and balancing

- The high strength laser cut steel extends the blade durability, whereas the tensioning process guarantees maximum precision.
- An automated system balances freud blades one by one, eliminating completely the harmful vibrations.

### Nema krivljenja testere: laserski sečen čelik, zategnut i balansiran

- Izuzetno izdržljiv laserski sečen čelik produžava vek trajanja testere, dok proces zatezanja garantuje maksimalnu preciznost.
- Automatizovan sistem balansira sve FREUD testere. eliminišući potpuno štetne vibracije.



Balancing.  
Balansiranje.

# Circular saw blades for INDUSTRIAL MACHINES

## Kružne testere za INDUSTRIJSKE MAŠINE

Choose the right tool  
Izaberite odgovarajući alat

\* LM10 - Only softwood  
\* LM10 - Samo meko drvo











Suitable for / Odgovarajuće za	PERFORMANCE / PERFORMANSE		
	Ultimate Najbolja	High Odlična	Good Dobra
 Multi-rip saw blades for ripping Testere za višelične cirkulare - uzdužan rez   Ripping Uzdužan rez   Cross cutting Poprečan rez   Ripping and cross cutting Uzdužan i poprečan rez	LM01 - LM10*	LM02-LM03-LM04-LM05- LM06-LM07-LM08	
	LU1F-LU1G	LU1C-LU1D-LU1E-LU2A- LU2B-LG1C	
	LU2A-LU2B-LU2C- LU2D-LU2F	LU2E-LG2C	LU1A-LU1E
		LG2A-LG2B-LU1H	LU1B
 Saw blades for cutting laminates Testere za rezanje laminata   Scoring saw blades for laminates Predrezači za laminate	<b>LSB X</b> LSB-LU3A-LU3B-LU3C- LU3D-LU3E-LU3F	LG3D	
	LI13MD-LI13MS-LI14MD- LI14MS-LI16M-LI17M- LI20M-LI22MD-LI22MS- LI25M-LI27M		
 Wood composites Drveni kompoziti	<b>LSB X</b> LSB-LU2C-LU2D-LU2E-LU2F- LU3A-LU3B-LU3C-LU3D-LU3F	LU2A-LU2B-LU3E- LG2A-LG2B-LG2C-LG3D	LU1E-LU1H
 Veneered Furnir	LU3A-LU3B-LU3C-LU3D- LU3E-LU3F	LG3D	
 Picture frames Ramovi	LU1I-LU1L		
 Non ferrous metals Obojeni metali	<b>LU5F</b> LU5A-LU5B-LU5C-LU5D- LU5E		
 Ferrous metals Crni metali	LU6A		
 Plexiglas Pleksiglas	LU4A-LU4B		
 Plastic materials Plastični materijali	<b>LU5F</b> LU4A-LU4B-LU5D-LU5B	LU2C-LU2D-LU2F- LG2C-LU3F	
 PVC PVC	<b>LU5F</b>	LU5B - LU5D	
 Solid surfaces Radne ploče	LU4D		

**GATECH**  
www.freud.rs

# Circular saw blades for PORTABLE MACHINES













## Kružne testere za RUČNE CIRKULARE

Choose the right tool  
Izaberite odgovarajući alat























Suitable for / Odgovarajuća za:	PERFORMANCE / PERFORMANSE		
	Ultimate Najbolja	High Odlična	Good Dobra
Solid wood Masiv	 Ripping Uzdužan rez	LP60M	
	 Cross cutting Poprečan rez	LP40M-LP60M	
	 Ripping and cross cutting Uzdužan i poprečan rez		LP20M-LP30M-LP60M LP70M
Laminated Laminati	 Saw blades for cutting laminates Testere za rezanje laminata	LP67M	LP85M-LP91M-LP40M
Wood composites Drveni kompoziti			LP91M LP40M
Veneered Furnir			LP91M
Non ferrous metals Obojeni metali		LP80M	LP85M-LP91M-LP40M
Ferrous metals Crni metali		LP90M	LP91M
Plexiglas & plastic materials Pleksiglas i plastični materijali			LP91M
PVC PVC			LP91M
Solid surfaces Radne ploče			LP91M

GATECH  
www.freud.rs

# Teeth shape varieties as applied to saw blades Vrste zuba po tipovima testera









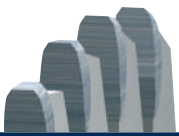

FLAT TOOTH RAVAN ZUB	DOUBLE TRIPLE CHIP TOOTH DUPLI TRAPEZNI ZUB	CONICAL TOOTH NAIZMENIČAN KOSI ZUB	BEVELLED TOOTH NAIZMENIČAN BW ZUB
LM01 - LM02 - LM05 - LM06 - LM07 - LM08 - LM10 - LU1E - LI20M - LI17M - LT18M - LT20M	LSC - LU4D - LU6A	LI25M	LU1B
			
<b>Suitable for / Odgovarajući za:</b>	<b>Suitable for / Odgovarajući za:</b>	<b>Suitable for / Odgovarajući za:</b>	<b>Suitable for / Odgovarajući za:</b>
 Ripping of softwood Legno tenero lungo vena	 Ferrous metals Metalli ferrosi	 Laminates (scoring saw blades) Laminati (lame incisore)	 Ripping and cross cutting of softwood Legno tenero lungo e trasverso vena
 Ripping of hardwood Legno duro lungo vena	 Solid surfaces Materiali polimerici		 Ripping and cross cutting of hardwood Legno duro lungo e trasverso vena
			 Chipboard Truciolare
			 Solid wood and composites with nails and impurities Legni e compositi con chiodi o impurità

GATECH  
www.freud.rs











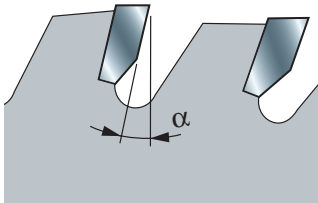
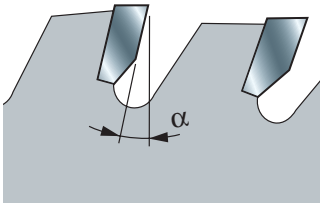
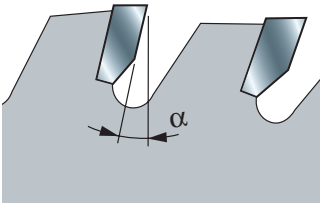
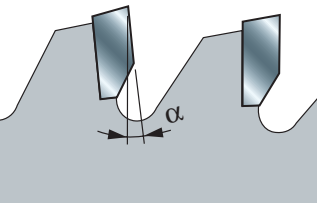



FLAT-TRIPLE CHIP TOOTH RAVAN - TRAPEZNI ZUB	INCLINED TOOTH KOSI ZUB	PYRAMID TOOTH PIRAMIDALNI ZUB	AXIAL TOOTH AKSIJALNI ZUB
LU3D - LU3E - LU3F - LG3D - LU4A - LU5A - LU5B - LU5C - LU5D - LU5E - LP40 - LP80 - LP90 - LP85 - LP91	LI22M - LI13M - LI14M - LT16M - LT12M - LT14M	LU5F	LU1L - LU4B
			
<b>Suitable for / Odgovarajući za:</b>	<b>Suitable for / Odgovarajući za:</b>	<b>Suitable for / Odgovarajući za:</b>	<b>Suitable for / Odgovarajući za:</b>
 Laminates / bilaminates Laminati / obostrano oplemenjeni pločasti materijali	 Cross cutting of soft-wood Poprečno rezanje mekog drveta	 PVC PVC	 Cross cutting of soft-wood Poprečno rezanje mekog drveta
 Chipboard Iverica	 Cross cutting of hard-wood Poprečno rezanje tvrdog drveta	 Non-ferrous metals Obojeni metali	 Cross cutting of hard-wood Poprečno rezanje tvrdog drveta
 MDF Medijapan (MDF)	 Laminates / bilaminates Laminati / obostrano oplemenjeni pločasti materijali		 Picture frames Ramovi za slike
 Plywood Furnir (šper)	 Plywood Furnir (šper)		 Plexiglas Pleksiglas
 Plexiglas Pleksiglas	 Scoring saw blades, for laminates Predrezači, za laminat		 Plastic materials Plastični materijali
 Plastic materials Plastični materijali			
 Non-ferrous metals Obojeni metali			

# Teeth shape varieties as applied to saw blades

## Vrste zuba po tipovima testera

CONCAVE TOOTH KONKAVNI ZUB	ROUNDED TOOTH ZAOBLJENI ZUB	ALTERNATE TOP BEVEL TOOTH NAIZMENIČNI BW ZUB
LU3B - LU3C	LU1G	LM03 - LM04 - LM08 - LU1A/C/D/F/H/I - LU2A/B/C/D/E/F - LU3A - LG1C - LG2A - LG2B - LG2C - LI16M LI27M - LP20M - LP30M - LP40M - LP60M - LP67M - LP70M
		
<b>Suitable for / \</b>	<b>Suitable for / \</b>	<b>Suitable for / \</b>
 Laminates / bilaminates Laminati / obostrano oplemenjeni pločasti materijali	 Ripping of softwood Uzdužno rezanje mekog drveta	 Ripping and cross cutting of softwood Uzdužno i poprečno rezanje mekog drveta
		 Ripping and cross cutting of hardwood Uzdužno i poprečno rezanje tvrdog drveta
		 Chipboard Iverica
		 MDF Medijapan (MDF)
		 Plywood Furnir (šper)
		 Picture frames Ramovi za slike

GATECH  
www.freud.rs

HOOK ANGLES GRUDNI UGLOVI			
( $\alpha$ ) 15° ÷ 25°	( $\alpha$ ) 5° ÷ 15°	( $\alpha$ ) 0° ÷ 5°	( $\alpha$ ) 0° ÷ -10°
			
<b>Suitable for / \</b>	<b>Suitable for / \</b>	<b>Suitable for / \</b>	<b>Suitable for / \</b>
 Cross cutting of softwood Poprečno rezanje mekog drveta	 Chipboard Iverica	 Chipboard Iverica	 Plexiglas Pleksiglas
 Cross cutting of hardwood Poprečno rezanje tvrdog drveta	 Plywood Furnir (šper)	 Non-ferrous metals Obojeni metali	 Plastic materials Plastični materijali
 Solid surfaces Kompaktni materijali (radne ploče)	 Laminates / bilaminates Laminati / obostrano oplemenjeni pločasti materijali	 Ferrous metals Crni metali	 Non-ferrous metals Obojeni metali
	 PVC PVC		 Laminates / bilaminates Laminati / obostrano oplemenjeni pločasti materijali



# LM01

## HW - Thin kerf multiripping saw blades with rakers TM - Tanke testere sa čistačima za višelisne cirkulare

Saw blades suitable for ripping where the thin body greatly reduces material wastes. Not suitable for twisted timber.

**Machines:** Multiripping machines, molders.

**Features:** Flat tooth.

**Material:** Soft and hardwood dried at max 10-12% humidity rate.

Testere za uzdužno rezanje kod kojih tanje telo značajno smanjuje količinu otpada pri rezanju.

**Mašine:** Višelisni cirkulari i četverostrane blanjalice.

**Oblik zuba:** Ravan zub.

**Materijal:** Meko i tvrdo drvo sa maksimalno 10-12% vlage.

**FT02:** 2/9/46,4 + 2/10/60

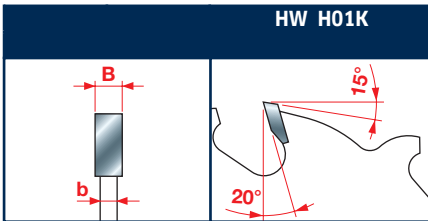
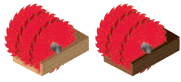
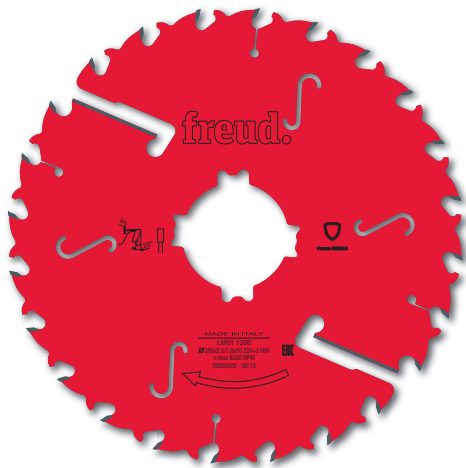

Tooth features - Karakteristike zuba

D	B	b	d	Z	KN	Code	SAP
mm	mm	mm	mm		Pomoćni otvori	Šifra	SAP
180	2,2	1,6	40	16+2	2CH 12x5	LM01 0100	F03FS02751
200	2,2	1,6	40	16+2	2CH 12x5	LM01 0200	F03FS02753
200	2,2	1,6	60	16+2	2CH 21x5	LM01 0300	F03FS02755
200	2,2	1,6	70	16+2	2CH 21x5	LM01 0400	F03FS02757
225	2,2	1,6	70	16+2	4CH 21x5	LM01 0500	F03FS02759
250	2,2	1,6	30	20+2	2CH 10x4 + FT02	LM01 0600	F03FS02763
250	2,2	1,6	60	20+2	4CH 21x5	LM01 0700	F03FS02765
250	2,2	1,6	70	20+2	4CH 21x5	LM01 0800	F03FS02767
250	2,2	1,6	80	20+2	2CH 13x5+2CH 21x5	LM01 0900	F03FS02769
250	2,2	1,6	50	24+2	4CH 21x5	LM01 1400	F03FS02780
250	2,2	1,6	60	24+2	4CH 21x5	LM01 1500	F03FS02781
250	2,2	1,6	70	24+2	4CH 21x5	LM01 1600	F03FS07200
300	2,5	1,8	30	24+2	2CH 10x4 + FT02	LM01 1000	F03FS02772
300	2,5	1,8	60	24+2	4CH 21x5	LM01 1100	F03FS02774
300	2,5	1,8	70	24+2	4CH 21x5	LM01 1200	F03FS02776
300	2,5	1,8	80	24+2	2CH 13x5+2CH 21x5	LM01 1300	F03FS02778

GATECH  
www.freud.rs

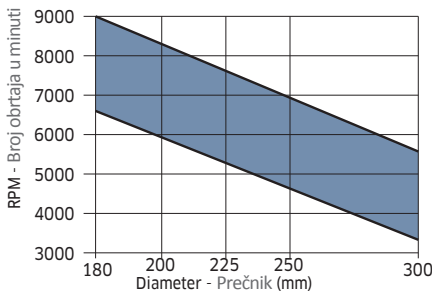

Minimum and maximum RPM based on the blade diameter.

Minimalan i maksimalan broj obrtaja u odnosu na prečnik testere.

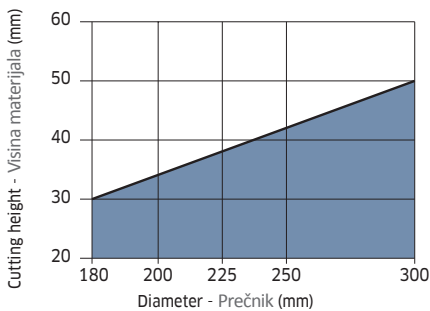

Maximum depth of cut based on the blade diameter.  
Maksimalna visina materijala koji se reže u odnosu na prečnik testere.

■ Solid wood  
Masiv

Ultimate Najbolja High Odlična Good Dobra

Ripping of softwood  
Uzdužno rezanje mekog drveta

Ripping of hardwood  
Uzdužno rezanje tvrdog drveta

# LM02

## HW - Reduced kerf multiripping saw blades with rakers TM - Testere redukovane debljine sa čistima za višelisne cirkulare

Saw blades suitable for ripping where the thin body greatly reduces material wastes.

**Machines:** Multiripping machines, molders.

**Features:** Flat tooth.

**Material:** Soft and hardwood dried at max 15% humidity rate.

Testere za uzdužno rezanje kod kojih tanje telo značajno smanjuje količinu otpada pri rezanju.

**Mašine:** Višelisni cirkulari i četverostrane blanjalice.

**Oblik zuba:** Ravan zub.

**Materijal:** Meko i tvrdo drvo sa maksimalno 15% vlage.

**FT02:** 2/9/46,4 + 2/10/60

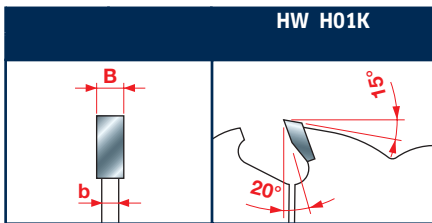
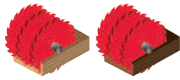

Tooth features - Karakteristike zuba

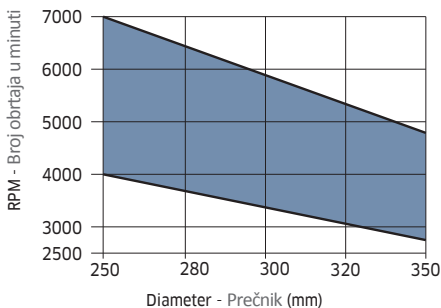

Minimum and maximum RPM based on the blade diameter.  
Minimalan i maksimalan broj obrtaja u odnosu na prečnik testere.

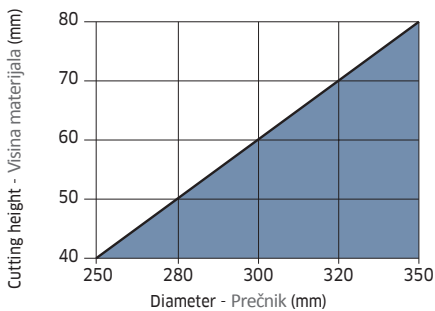

Maximum depth of cut based on the blade diameter.  
Maksimalna visina materijala koji se reže u odnosu na prečnik testere.

■ Solid wood  
Masiv

D	B	b	d	Z	KN	Code	SAP
mm	mm	mm	mm		Pomoćni otvori	Šifra	SAP
250	2,8	2,0	30	16+2	2CH 10x4 + FT02	LM02 0100	F03FS02797
250	2,8	2,0	60	16+2	4CH 21x5	LM02 0200	F03FS02799
250	2,8	2,0	70	16+2	4CH 21x5	LM02 0300	F03FS02801
250	2,8	2,0	80	16+2	2CH 13x5+2CH 21x5	LM02 0400	F03FS02803
280	2,8	2,0	80	18+2	2CH 13x5+2CH 21x5	LM02 0500	F03FS02805
300	2,8	2,0	30	20+2	2CH 10x4 + FT02	LM02 0600	F03FS02807
300	2,8	2,0	60	20+2	4CH 21x5	LM02 0700	F03FS02809
300	2,8	2,0	70	20+2	4CH 21x5	LM02 0800	F03FS02811
300	2,8	2,0	80	20+2	2CH 13x5+2CH 21x5	LM02 0900	F03FS02813
320	3,0	2,2	30	20+2+2	2CH 10x4 + FT02	LM02 1000	F03FS02815
320	3,0	2,2	80	20+2+2	2CH 13x5+2CH 21x5	LM02 1100	F03FS02817
350	3,0	2,2	30	24+2+2	2CH 10x4 + FT02	LM02 1200	F03FS02819
350	3,0	2,2	60	24+2+2	4CH 21x5	LM02 1300	F03FS02821
350	3,0	2,2	70	24+2+2	4CH 21x5	LM02 1400	F03FS02823
350	3,0	2,2	80	24+2+2	2CH 13x5+2CH 21x5	LM02 1500	F03FS02825

GATECH  
www.freud.rs

Ultimate Najbolja	High Odlična	Good Dobra
	●	
	●	

Ripping of softwood  
Uzdužno rezanje mekog drveta  
Ripping of hardwood  
Uzdužno rezanje tvrdog drveta

# LM03

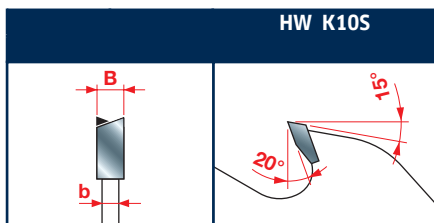
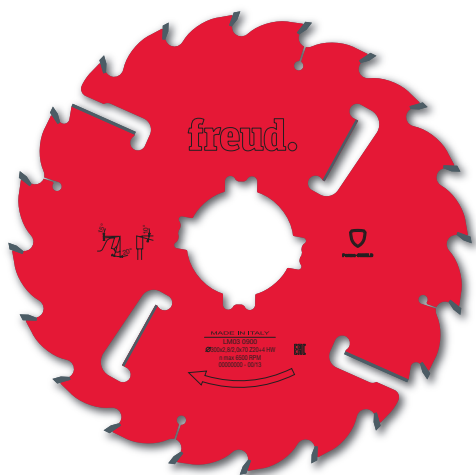

Tooth features - Karakteristike zuba

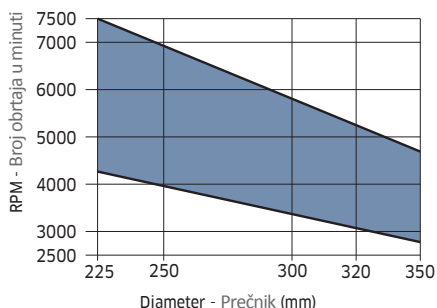

Minimum and maximum RPM based on the blade diameter.  
Minimalan i maksimalan broj obrtaja u odnosu na prečnik testere.

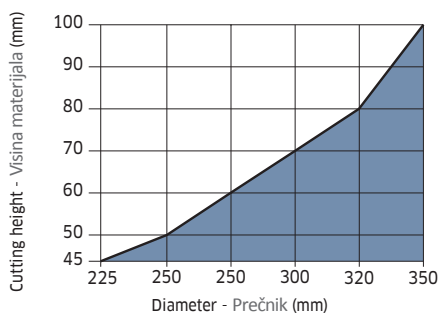

Maximum depth of cut based on the blade diameter.  
Maksimalna visina materijala koji se reže u odnosu na prečnik testere.

■ Solid wood  
Masiv

## HW - Reduced kerf multiripping saw blades with rakers TM - Testere redukovane debljine sa čistačima za višelisne cirkulare

Saw blades suitable for ripping where the thin body greatly reduces material wastes. Not suitable for cutting poplar.

**Machines:** Multiripping machines.

**Features:** ATB 10° tooth.

**Material:** Soft and hardwood dried at max 15% humidity rate.

Testere za uzdužno rezanje kod kojih tanje telo značajno smanjuje količinu otpada pri rezanju. Nisu podobne za rezanje TOPOLE.

Mašine: Višelisni cirkulari.

Oblik zuba: ATB 10°.

Materijal: Meko i tvrdo drvo sa maksimalno 15% vlage.

**FT02:** 2/9/46,4 + 2/10/60

D	B	b	d	Z	KN	Code	SAP
mm	mm	mm	mm		Pomoćni otvori	Šifra	SAP
225	2,5	1,8	70	16+2+2	4CH 21x5	<b>LM03 0100</b>	F03FS02843
250	2,8	2,0	30	16+2+2	2CH 10x4 + FT02	<b>LM03 0200</b>	F03FS02845
250	2,8	2,0	60	16+2+2	4CH 21x5	<b>LM03 0300</b>	F03FS02847
250	2,8	2,0	70	16+2+2	4CH 21x5	<b>LM03 0400</b>	F03FS02849
250	2,8	2,0	80	16+2+2	2CH 13x5+2CH 21x5	<b>LM03 0500</b>	F03FS02851
280	2,8	2,0	80	18+2+2	2CH 13x5+2CH 21x5	<b>LM03 0600</b>	F03FS02853
300	2,8	2,0	30	20+2+2	2CH 10x4 + FT02	<b>LM03 0700</b>	F03FS02855
300	2,8	2,0	60	20+2+2	4CH 21x5	<b>LM03 0800</b>	F03FS02857
300	2,8	2,0	70	20+2+2	4CH 21x5	<b>LM03 0900</b>	F03FS02859
300	2,8	2,0	80	20+2+2	2CH 13x5+2CH 21x5	<b>LM03 1000</b>	F03FS02861
320	3,0	2,2	30	20+2+2	2CH 10x4 + FT02	<b>LM03 1100</b>	F03FS02863
320	3,0	2,2	80	20+2+2	2CH 13x5+2CH 21x5	<b>LM03 1200</b>	F03FS02865
350	3,0	2,2	30	24+2+2	2CH 10x4	<b>LM03 1300</b>	F03FS02867
350	3,0	2,2	60	24+2+2	4CH 21x5	<b>LM03 1400</b>	F03FS02869
350	3,0	2,2	70	24+2+2	4CH 21x5	<b>LM03 1500</b>	F03FS02871
350	3,0	2,2	80	24+2+2	2CH 13x5+2CH 21x5	<b>LM03 1600</b>	F03FS02873
350	3,0	2,2	90	24+2+2	4CH 20x7	<b>LM03 1700</b>	F03FS05808

**GATECH**  
www.freud.rs

Ultimate Najbolja	High Odlična	Good Dobra
	●	
	●	

Ripping of softwood  
Uzdužno rezanje mekog drveta

Ripping of hardwood  
Uzdužno rezanje tvrdog drveta

# LM04

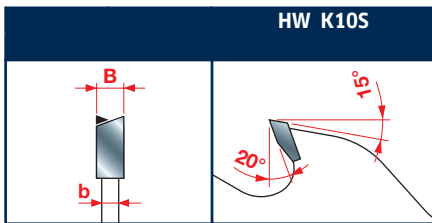

Tooth features - Karakteristike zuba

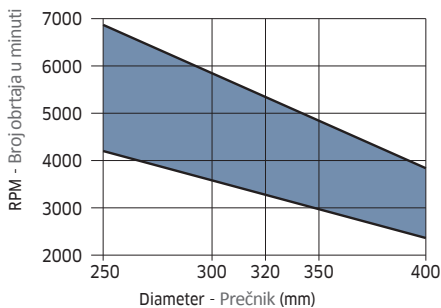

Minimum and maximum RPM based on the blade diameter.  
Minimalan i maksimalan broj obrtaja u odnosu na prečnik testere.

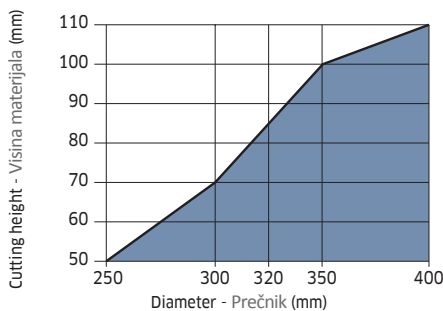

Maximum depth of cut based on the blade diameter.  
Maksimalna visina materijala koji se reže u odnosu na prečnik testere.

■ Solid wood  
Masiv

## HW - Multiripping saw blades with rakers TM - Testere sa čistačima za višelisne cirkulare

Saw blades suitable for ripping.

**Machines:** Multiripping machines.

**Features:** ATB 10° tooth.

**Material:** Soft and hardwood dried at 15% humidity rate.

T

**Mašine:** †

**Oblik zuba:** ° u'

**Materijal:** U

**FT02:** 2/9/46,4 + 2/10/60

D	B	b	d	Z	KN	Code	SAP
mm	mm	mm	mm		Pomoćni otvori	Šifra	SAP
250	3,2	2,2	30	20+2+2	2CH 10x4 + FT02	LM04 0100	F03FS02891
250	3,2	2,2	60	20+2+2	4CH 21x5	LM04 0200	F03FS02893
250	3,2	2,2	70	20+2+2	4CH 21x5	LM04 0300	F03FS02895
250	3,2	2,2	80	20+2+2	2CH 13x5+2CH 21x5	LM04 0400	F03FS02897
300	3,2	2,2	30	24+2+2	2CH 10x4 + FT02	LM04 0500	F03FS02899
300	3,2	2,2	60	24+2+2	4CH 21x5	LM04 0600	F03FS02901
300	3,2	2,2	70	24+2+2	4CH 21x5	LM04 0700	F03FS02903
300	3,2	2,2	80	24+2+2	2CH 13x5+2CH 21x5	LM04 0800	F03FS02906
320	3,2	2,2	30	24+2+2	2CH 10x4 + FT02	LM04 0900	F03FS02908
320	3,2	2,2	80	24+2+2	2CH 13x5+2CH 21x5	LM04 1000	F03FS02910
350	3,5	2,5	70	24+2+4	4CH 21x5	LM04 2400	F03FS06243
350	3,5	2,5	80	24+2+4	2CH 13x5+2CH 21x5	LM04 2500	F03FS06244
350	3,5	2,5	30	28+2+4	2CH 10x4 + FT02	LM04 1100	F03FS02912
350	3,5	2,5	60	28+2+4	4CH 21x5	LM04 1200	F03FS02914
350	3,5	2,5	70	28+2+4	4CH 21x5	LM04 1300	F03FS02916
350	3,5	2,5	80	28+2+4	2CH 13x5+2CH 21x5	LM04 1400	F03FS02919
350	3,5	2,5	90	28+2+4	4CH 21x5	LM04 2200	F03FS02935
400	4,0	2,8	30	28+2+4	2CH 10x4 + FT02	LM04 1500	F03FS02921
400	4,0	2,8	70	28+2+4	4CH 21x5	LM04 1600	F03FS02923
400	4,0	2,8	80	28+2+4	2CH 13x5+2CH 21x5	LM04 1700	F03FS02926

GATECH  
www.freud.rs

Ultimate Najbolja	High Odlična	Good Dobra
	●	
	●	

Ripping of softwood  
Uzdužno rezanje mekog drveta  
Ripping of hardwood  
Uzdužno rezanje tvrdog drveta

# LM05

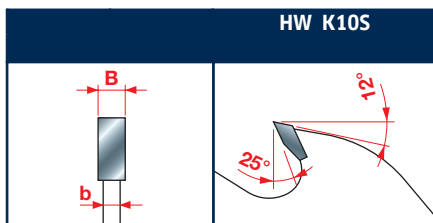

Tooth features - Karakteristike zuba

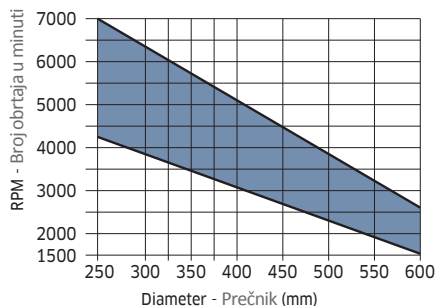

Minimum and maximum RPM based on the blade diameter.  
Minimalan i maksimalan broj obrtaja u odnosu na prečnik testere.

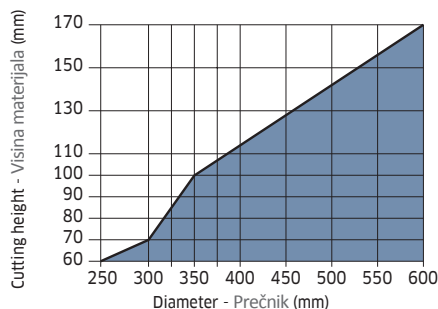

Maximum depth of cut based on the blade diameter.  
Maksimalna visina materijala koji se reže u odnosu na prečnik testere.

■ Solid wood  
Masiv

## HW - Multiripping saw blades with rakers TM - Testere sa čistačima za višelisne cirkulare

Saw blades for ripping extra thick timber. Particularly suitable in sawmills for cutting wood with humidity rate over 10%.

**Machines:** Multiripping machines.

**Features:** Flat tooth.

**Material:** Soft and hardwood and long fibre wood.

Testere za uzdužno rezanje debelog drveta. Posebno pogodne za pilane i rezanje vlažnog drveta sa preko 10% vlage.

**Mašine:** Višelisni cirkulari.

**Oblik zuba:** Ravan.

**Materijal:** Meko i tvrdo drvo, drvo dugog vlakna (TOPOLA).

**FT02:** 2/9/46,4 + 2/10/60

D	B	b	d	Z	KN	Code	SAP
mm	mm	mm	mm		Pomoćni otvori	Šifra	SAP
250	3,4	2,2	30	16+2+2	2CH 10x4 + FT02	LM05 0100	F03FS02973
250	3,4	2,2	60	16+2+2	4CH 21x5	LM05 0200	F03FS02975
250	3,4	2,2	70	16+2+2	4CH 21x5	LM05 0300	F03FS02977
250	3,4	2,2	80	16+2+2	2CH 13x5+2CH 21x5	LM05 0400	F03FS02979
300	3,4	2,2	30	20+2+2	2CH 10x4 + FT02	LM05 0500	F03FS02981
300	3,4	2,2	60	20+2+2	4CH 21x5	LM05 0600	F03FS02983
300	3,4	2,2	70	20+2+2	4CH 21x5	LM05 0700	F03FS02985
300	3,4	2,2	80	20+2+2	2CH 13x5+2CH 21x5	LM05 0800	F03FS02990
320	3,4	2,2	30	20+2+2	2CH 10x4 + FT02	LM05 0900	F03FS02993
320	3,4	2,2	80	20+2+2	2CH 13x5+2CH 21x5	LM05 1000	F03FS02995
350	3,7	2,5	30	20+2+4	2CH 10x4 + FT02	LM05 1100	F03FS02997
350	3,7	2,5	50	20+2+4	2CH 10x4	LM05 1200	F03FS02999
350	3,7	2,5	60	20+2+4	4CH 21x5	LM05 1300	F03FS03001
350	3,7	2,5	70	20+2+4	4CH 21x5	LM05 1400	F03FS03003
350	3,7	2,5	80	20+2+4	2CH 13x5+2CH 21x5	LM05 1500	F03FS03005
350	3,7	2,5	90	20+2+4	4CH 21x5	LM05 4100	F03FS03060
380	4,0	2,8	30	20+2+4	2CH 10x4 + FT02	LM05 1600	F03FS03007
380	4,0	2,8	70	20+2+4	4CH 21x5	LM05 1700	F03FS03009
380	4,0	2,8	80	20+2+4	2CH 13x5+2CH 21x5	LM05 1800	F03FS03011
400	4,0	2,8	30	24+2+4	2CH 10x4 + FT02	LM05 1900	F03FS03013
400	4,0	2,8	50	24+2+4	2CH 10x4	LM05 2000	F03FS03015
400	4,0	2,8	70	24+2+4	4CH 21x5	LM05 2100	F03FS03017
400	4,0	2,8	80	24+2+4	2CH 13x5+2CH 21x5	LM05 2200	F03FS03019
450	4,4	3,0	30	24+2+4	2CH 10x4 + FT02	LM05 2400	F03FS03023
450	4,4	3,0	50	24+2+4	2 CH 10x4	LM05 2500	F03FS03025
450	4,4	3,0	70	24+2+4	4CH 21x5	LM05 2600	F03FS03027
450	4,4	3,0	80	24+2+4	2CH 13x5+2CH 21x5	LM05 2700	F03FS03029
500	4,8	3,5	30	28+2+4	FT02+2CH 10x4	LM05 2900	F03FS03033
500	4,8	3,5	50	28+2+4	2CH 10x4	LM05 3000	F03FS03036
500	4,8	3,5	70	28+2+4	4CH 21x5	LM05 3100	F03FS03039
500	4,8	3,5	80	28+2+4	2CH 13x5+2CH 21x5	LM05 3200	F03FS03041
550	4,8	3,5	30	28+2+4	2CH 10x4 + FT02	LM05 3400	F03FS03045
550	4,8	3,5	50	28+2+4	2CH 10x4	LM05 3500	F03FS03047
550	4,8	3,5	70	28+2+4	4CH 21x5	LM05 3600	F03FS03050
550	4,8	3,5	80	28+2+4	2CH 13x5+2CH 21x5	LM05 3700	F03FS03052
600	5,2	3,5	30	32+2+4	2CH 10x4	LM05 4200	F03FS05860
600	5,2	3,5	80	32+2+4	4CH 21x5	LM05 3900	F03FS03056

GATECH  
www.freud.rs

Ultimate Najbolja	High Odlična	Good Dobra
	●	
	●	

Ripping of softwood  
Uzdužno rezanje mekog drveta

Ripping of hardwood  
Uzdužno rezanje tvrdog drveta



# LM06

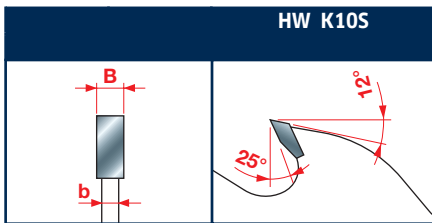
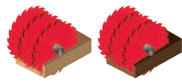

Tooth features - Karakteristike zuba

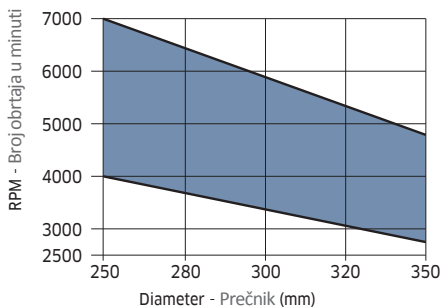

Minimum and maximum RPM based on the blade diameter.

Minimalan i maksimalan broj obrtaja u odnosu na prečnik testere.

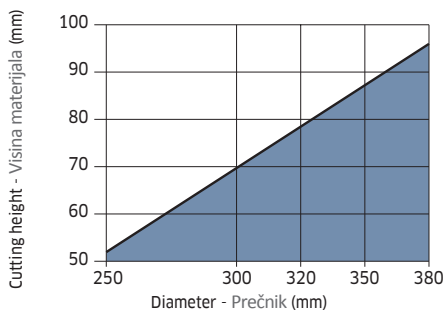

Maximum depth of cut based on the blade diameter. Maksimalna visina materijala koji se reže u odnosu na prečnik testere.

■ Solid wood  
Masiv

## HW - Increased kerf multiripping saw blades TM - Testere povećane debljine za višelisne cirkulare

Saw blades for ripping extra thick timber. Most suitably employed in sawmills when cutting wet wood and with a high resin content.

**Machines:** Multiripping machines.

**Features:** Flat tooth.

**Material:** Humid over 10% soft and hardwood and long fibre wood.

Testere za uzdužno rezanje debelog drveta. Posebno pogodne za pilane i rezanje vlažnog drveta i drveta sa velikim sadržajem smole.

**Mašine:** Višelisni cirkulari.

**Oblik zuba:** Ravan.

**Materijal:** Meko i tvrdo drvo sa preko 10% vlage, drvo dugog vlakna (TOPOLA), drvo sa velikim sadržajem smole (ČETINARI).

**FT02:** 2/9/46,4 + 2/10/60

D	B	b	d	Z	KN	Code	SAP
mm	mm	mm	mm		Pomoćni otvori	Šifra	SAP
250	4,2	3,0	30	16+2+2	2CH 10x4 + FT02	LM06 0100	F03FS03104
250	4,2	3,0	60	16+2+2	4CH 21x5	LM06 0200	F03FS03106
250	4,2	3,0	70	16+2+2	4CH 21x5	LM06 0300	F03FS03108
250	4,2	3,0	80	16+2+2	2CH 21x5+2CH13x5	LM06 0400	F03FS03110
300	3,5	2,5	70	20+2+2	4CH 21x5	LM06 1500	F03FS03133
300	3,5	2,5	80	20+2+2	2CH 13x5+2CH 21x5	LM06 1600	F03FS03135
300	4,2	3,0	30	20+2+2	2CH 10x4 + FT02	LM06 0500	F03FS03113
300	4,2	3,0	60	20+2+2	4CH 21x5	LM06 0600	F03FS03115
300	4,2	3,0	70	20+2+2	4CH 21x5	LM06 0700	F03FS03117
300	4,2	3,0	80	20+2+2	2CH 13x5+2CH 21x5	LM06 0800	F03FS03119
320	4,2	3,0	30	20+2+2	2CH 10x4 + FT02	LM06 0900	F03FS03121
320	4,2	3,0	70	20+2+2	4CH 21x5	LM06 1900	F03FS03140
320	4,2	3,0	80	20+2+2	2CH 13x5+2CH 21x5	LM06 1000	F03FS03123
350	4,2	3,0	30	20+2+4	2CH 10x4 + FT02	LM06 1100	F03FS03125
350	4,2	3,0	50	20+2+4	2CH 10x4	LM06 1800	F03FS03138
350	4,2	3,0	60	20+2+4	4CH 21x5	LM06 1200	F03FS03127
350	4,2	3,0	70	20+2+4	4CH 21x5	LM06 1300	F03FS03129
350	4,2	3,0	80	20+2+4	2CH 13x5+2CH 21x5	LM06 1400	F03FS03131

GATECH  
www.freud.rs

Ultimate Najbolja	High Odlična	Good Dobra
	●	
	●	

Ripping of softwood  
Uzdužno rezanje mekog drveta  
Ripping of hardwood  
Uzdužno rezanje tvrdog drveta

# LM07

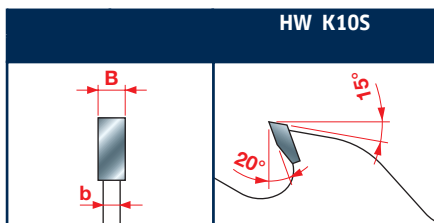

Tooth features - Karakteristike zuba

## HW - Shoulder thick kerf saw blades with rakers TM - Debele testere sa čistačima za višelisne cirkulare

Saw blades for ripping. Essential for ensuring correct distribution of lateral forces created by crooked plank in heavy duty use. Use as a shoulder saw blade on multiripping machines.

**Machines:** Multiripping machines.

**Features:** Flat tooth.

**Material:** Solid hard and softwood, dried and wet.

Testere za uzdužno rezanje. Idealne za obezbeđivanje pravilne raspodele bočnih sila koje stvara kriva daska. Preporuka za krajnje testere na višelisnim cirkularima.

**Mašine:** Višelisni cirkulari.

**Oblik zuba:** Ravan.

**Materijal:** Meko i tvrdo drvo, suvo ili vlažno.

**FT02:** 2/9/46,4 + 2/10/60

D	B	b	d	Z	KN	Code	SAP
mm	mm	mm	mm		Pomoćni otvori	Šifra	SAP
250	5,5	3,5	30	16+2+2	2CH 10x4 + FT02	LM07 0100	F03FS03141
250	5,5	3,5	60	16+2+2	4CH 21x5	LM07 0200	F03FS03143
250	5,5	3,5	70	16+2+2	4CH 21x5	LM07 0300	F03FS03145
250	5,5	3,5	80	16+2+2	2CH 13x5+2CH 21x5	LM07 0400	F03FS03147
300	5,5	3,5	30	20+2+2	2CH 10x4 + FT02	LM07 0500	F03FS03149
300	5,5	3,5	60	20+2+2	4CH 21x5	LM07 0600	F03FS03151
300	5,5	3,5	70	20+2+2	4CH 21x5	LM07 0700	F03FS03153
300	5,5	3,5	80	20+2+2	2CH 13x5+2CH 21x5	LM07 0800	F03FS03155
320	5,5	3,5	30	20+2+2	2CH 10x4 + FT02	LM07 0900	F03FS03157
320	5,5	3,5	80	20+2+2	2CH 13x5+2CH 21x5	LM07 1000	F03FS03159
350	5,5	3,5	30	24+2+4	2CH 10x4 + FT02	LM07 1100	F03FS03161
350	5,5	3,5	60	24+2+4	4CH 21x5	LM07 1200	F03FS03163
350	5,5	3,5	70	24+2+4	4CH 21x5	LM07 1300	F03FS03165
350	5,5	3,5	80	24+2+4	4CH 21x5	LM07 1400	F03FS03167

GATECH  
www.freud.rs

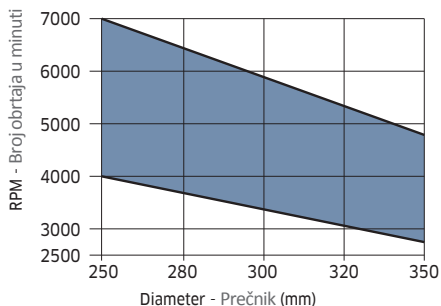

Minimum and maximum RPM based on the blade diameter.  
Minimalan i maksimalan broj obrtaja u odnosu na prečnik testere.

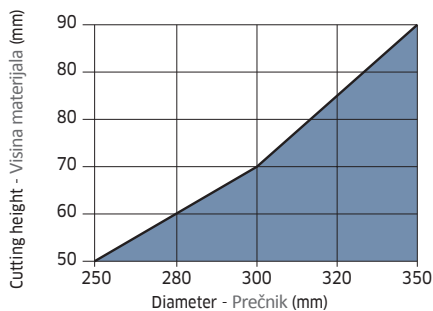

Maximum depth of cut based on the blade diameter.  
Maksimalna visina materijala koji se reže u odnosu na prečnik testere.

■ Solid wood  
Masiv

Ultimate Najbolja	High Odlična	Good Dobra
----------------------	-----------------	---------------

Ripping of softwood  
Uzdužno rezanje mekog drveta

Ripping of hardwood  
Uzdužno rezanje tvrdog drveta

# LM08

## HW - Ultra-thin kerf multiripping saw blades

### TM - Izuzetno tanke (krajnje) testere za višelisne cirkulare

Saw blades for ripping, mostly suited when wastes must be brought down to a minimum. **Reboring and keyways optional not available. We recommend the saw blade to be regularly cleaned in order to prevent the formation of resin deposits.**

**Machines:** Molders and cleaving machines.

**Features:** Flat tooth (P) or ATB tooth.

**Material:** Good quality soft and hardwood dried at max 10% humidity rate.

Testere za uzdužno rezanje drveta kada je vitalno da količina otpadaka bude svedena na minimum. **Preporučujemo redovno čišćenje testera da bi se izbeglo nagomilavanje smole.**

**Mašine:** Višelisni cirkulari, mašine za sečenje lamela.

**Oblik zuba:** Ravan (P) ili ATB zub.

**Materijal:** Kvalitetno meko i tvrdo drvo sa maksimalno 10% vlage.

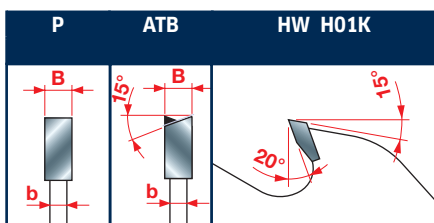
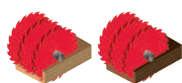

Tooth features - Karakteristike zuba

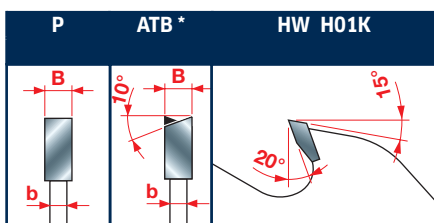

Tooth features - Karakteristike zuba

D	B	b	d	Z	NL - KN	Code	SAP
mm	mm	mm	mm		Pomoćni otvori	Šifra	SAP
180	1,5	1,0	40	24	P	2CH 12x5	LM08 0100 F03FS03169
180	1,5	1,0	60	24	P	FT 3/10/75	LM08 0200 F03FS03171
200	1,5	1,0	40	28	P	2CH 12x5	LM08 0300 F03FS03173
200	1,5	1,0	60	28	P	FT 3/10/75	LM08 0400 F03FS03176
200	1,5	1,0	60	36	ATB*	FT 3/10/75	LM08 0500 F03FS03179
200	1,7	1,2	50	36	ATB*		LM08 0600 F03FS03182
200	1,7	1,2	60	36	ATB*	FT 3/10/75	LM08 2800 F03FS03240
225	1,5	1,0	40	28	P	2CH 12x5	LM08 0700 F03FS03185
225	1,5	1,0	60	28	P	FT 3/10/75	LM08 0800 F03FS03188
225	1,5	1,0	70	28	P	2CH 21x5	LM08 0900 F03FS03191
225	1,5	1,0	40	36	ATB	2CH 12x5	LM08 1000 F03FS03194
225	1,5	1,0	60	36	ATB	FT 3/10/75	LM08 1100 F03FS03197
225	1,5	1,0	70	36	ATB	2CH 21x5	LM08 1200 F03FS03200
225	1,7	1,2	65	36	ATB	FT 3/10/80	LM08 1300 F03FS03203
250	1,7	1,2	40	24	P	2CH 12x5	LM08 1400 F03FS03206
250	1,7	1,2	60	24	P	FT 3/10/75	LM08 1500 F03FS03209
250	1,7	1,2	70	24	P	2CH 21x5	LM08 1600 F03FS03212
250	1,7	1,2	40	36	ATB*	2CH 12x5	LM08 1700 F03FS03215
250	1,7	1,2	60	36	ATB*	FT 3/10/75	LM08 1800 F03FS03218
250	1,7	1,2	70	36	ATB	2CH 21x5	LM08 1900 F03FS03223
250	2,2	1,6	50	30	ATB*	2CH 21x5	LM08 2500 F03FS03237
250	2,2	1,6	60	30	ATB*	2CH 21x5	LM08 2600 F03FS03238
250	2,2	1,6	70	30	ATB*	2CH 21x5	LM08 2700 F03FS03239
255	1,7	1,2	70	24	P	2CH 21x5	LM08 2400 F03FS03236
280	2,2	1,6	60	36	ATB	FT 3/10/75	LM08 2200 F03FS03232
300	2,2	1,6	50	36	ATB		LM08 2000 F03FS03226
300	2,2	1,6	70	36	ATB	2CH 21x5	LM08 2300 F03FS03235
350	2,5	1,8	50	40	ATB		LM08 2100 F03FS03229

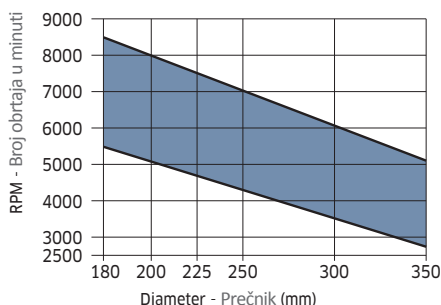

Minimum and maximum RPM based on the blade diameter.  
Minimalan i maksimalan broj obrtaja u odnosu na prečnik testere.

■ Solid wood  
■ Masiv

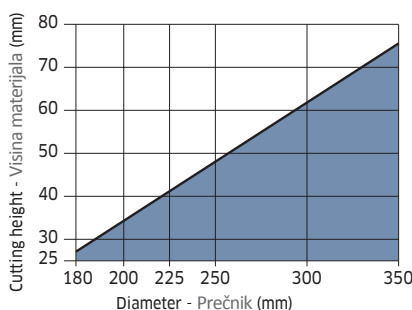

Maximum depth of cut based on the blade diameter.  
Maksimalna visina materijala koji se reže u odnosu na prečnik testere.

GATECH  
www.freud.rs

Ultimate Najbolja	High Odlična	Good Dobra
	●	
	●	

Ripping of softwood  
Uzdužno rezanje mekog drveta  
Ripping of hardwood  
Uzdužno rezanje tvrdog drveta

# LM10

**new**  
**ново**

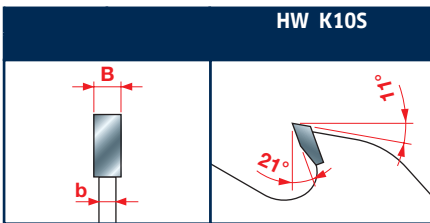
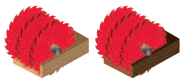
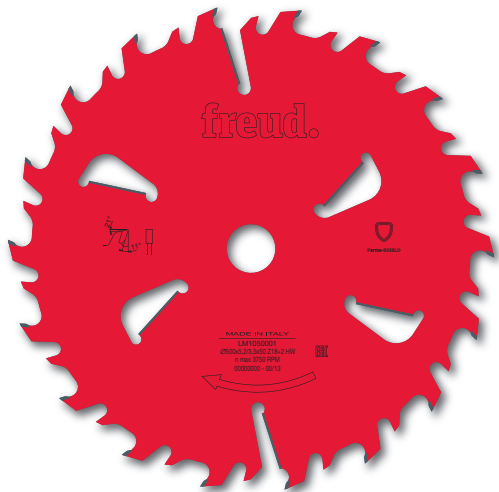

Tooth features - Karakteristike zuba

## HW - Multiripping saw blades with rakers for soft wet wood TM - Testere sa čistačima za višelisne cirkulare, za rezanje mekog i vlažnog drveta

Saw blades for ripping extra thick timber. Most suitably employed in sawmills when cutting wet wood and with a high resin content.

**Machines:** Multiripping machines, single or double arbor.

**Features:** Flat tooth. The special gullets are designed to significantly improve chip evacuation with the support of the internal rakers slots. The blade stays cleaner for longer, therefore limiting the dull-wear of the cutting edges.

**Material:** Wet softwood (e.g. pine, spruce, poplar).

Testere za uzdužno rezanje izuzetno debelog drveta. Posebno pogodne za pilane i rezanje vlažnog drveta i drveta sa visokim sadržajem smole.

**Mašine:** Višelisni cirkulari, sa jednim ili dva vretena.

**Oblik zuba:** Ravan. Specijalno dizajnirano međuzublje i čistači omogućavaju bolje izbacivanje piljevine. Testera duže ostaje čista uz smanjeno habanje zuba.

**Materijal:** Meko drvo sa visokim stepenom vlage (bor, jela, topola).

	D	B	b	d	Z	KN	Code	SAP
	mm	mm	mm	mm		Pomoćni otvori	Šifra	SAP
novi	350	3,9	2,5	50	18+2+2		LM1035001	F03FS07701
novi	400	4,4	3,0	50	18+2+2		LM1040001	F03FS07702
novi	450	4,8	3,0	50	18+2+4		LM1045001	F03FS07703
novi	500	5,2	3,5	50	18+2+4		LM1050001	F03FS07704
novi	560	5,5	3,5	50	18+2+4		LM1056001	F03FS07705

**GATECH**  
www.freud.rs

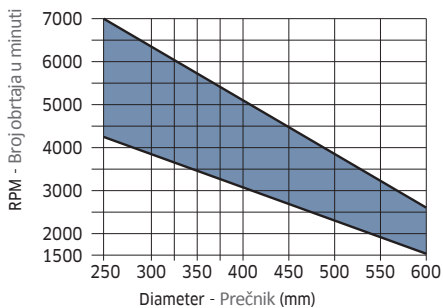

Minimum and maximum RPM based on the blade diameter.  
Minimalan i maksimalan broj obrtaja u odnosu na prečnik testere.

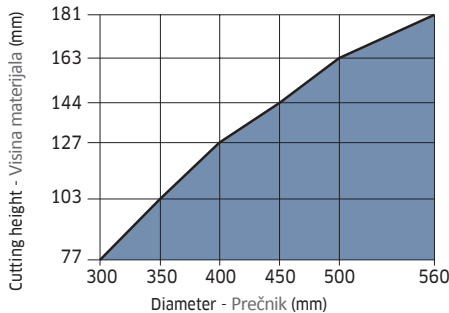

Maximum depth of cut based on the blade diameter.  
Maksimalna visina materijala koji se reže u odnosu na prečnik testere.

■ Solid wood  
Masiv

**Ultimate**      **High**      **Good**  
**Najbolja**      **Odlična**      **Dobra**

Ripping of softwood  
Uzdužno rezanje mekog drveta



# LU1A

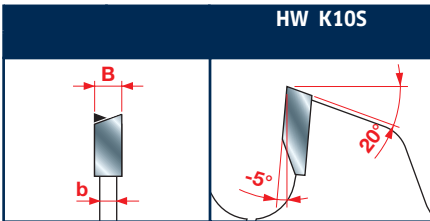
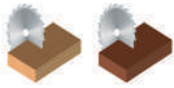

Tooth features - Karakteristike zuba

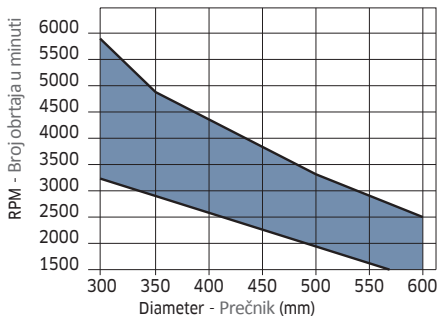

Minimum and maximum RPM based on the blade diameter.  
Minimalan i maksimalan broj obrtaja u odnosu na prečnik testere.

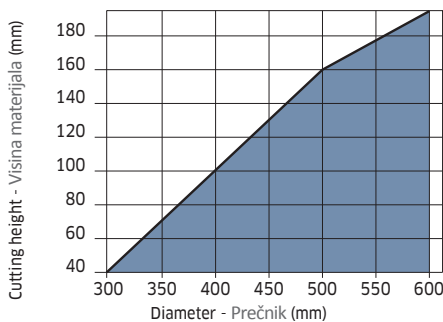

Maximum depth of cut based on the blade diameter.  
Maksimalna visina materijala koji se reže u odnosu na prečnik testere.

■ Solid wood  
Masiv

## HW - Saw blades for radial and pendulum machines TM - Testere za pomezne prezeivače

Saw blades suitable for crosscutting.

**Machines:** Radial, pendulum and portable machines.

**Features:** ATB 15° tooth with negative cutting angle.

**Material:** Soft, hard, dried and wet solid wood.

Testere za poprečno rezanje.

**Mašine:** Pomezni prezeivači, prenosni cirkulari.

**Oblik zuba:** ATB 15° sa negativnim uglom rezanja.

**Materijal:** Meko i tvrdo drvo, suvo ili vlažno.

**FT02:** 2/9/46,4 + 2/10/60

**FT03:** 2/7/42 + 2/10/60

D	B	b	d	Z	NL	Code	SAP
mm	mm	mm	mm		Pomoćni otvori	Šifra	SAP
300	4,4	3,0	30	36	FT02	LU1A 0100	F03FS04572
350	4,4	3,0	30	42	2/10/60	LU1A 0200	F03FS04573
400	4,4	3,0	30	48	FT02	LU1A 0300	F03FS04574
450	4,4	3,0	30	54	FT03	LU1A 0400	F03FS04575
500	4,8	3,2	30	60	2/10/60	LU1A 0500	F03FS04576
550	4,8	3,2	30	72	2/10/60	LU1A 0600	F03FS04577
600	5,0	3,5	30	72	FT02	LU1A 0700	F03FS04578

GATECH  
www.freud.rs

### Working with spindle over the workpiece

Mašinska obrada sa osovinom iznad radne površine

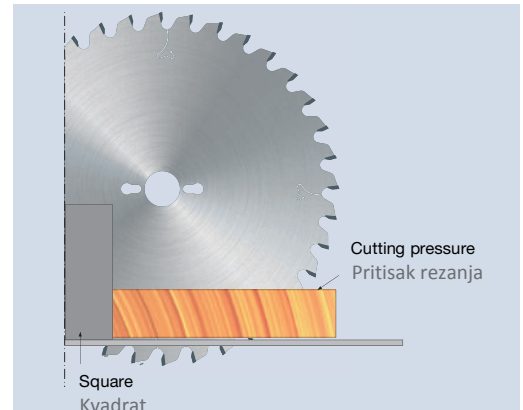

Ultimate Najbolja	High Odlična	Good Dobra
----------------------	-----------------	---------------

Cross cutting of softwood  
Poprečno rezanje mekog drveta

Cross cutting of hardwood  
Poprečno rezanje tvrdog drveta





# LU1B

## HW - Saw blades for carpentry works

### TM - Testere za stolarske radove

Saw blades suitable for ripping and crosscutting.

**Machines:** Table saws, portable machines.

**Features:** ATB/bevelled tooth with positive cutting angle.

**Material:** Soft and hard solid wood and panels, even in case of nails or metal clips.

Testere za uzdužno i poprečno rezanje.

**Mašine:** Stabilni cirkulari, prenosni cirkulari.

**Oblik zuba:** ATB/smaknuti zub sa pozitivnim uglom rezanja.

**Materijal:** Meko i tvrdo drvo i drveni paneli, čak i sa prisustvom eksera ili metalnih klamerica.

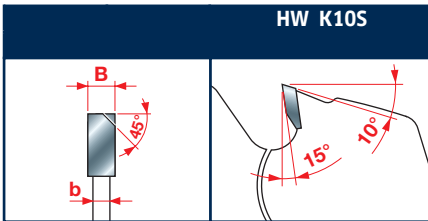

Tooth features - Karakteristike zuba

**FT01:** 2/7/42 + 2/9/46,4 + 2/10/60

**FT02:** 2/9/46,4 + 2/10/60

**FT03:** 2/7/42 + 2/10/60

D	B	b	d	Z	NL	Code	SAP
mm	mm	mm	mm		Pomoćni otvori	Šifra	SAP
250	3,4	2,2	30	18	FT01	<b>LU1B 0100</b>	F03FS04579
300	3,4	2,2	30	20	FT01	<b>LU1B 0200</b>	F03FS04580
315	3,4	2,2	30	20	FT01	<b>LU1B 0300</b>	F03FS04582
350	3,7	2,5	30	24	FT02	<b>LU1B 0400</b>	F03FS04583
400	4,0	2,8	30	28	2/10/60	<b>LU1B 0500</b>	F03FS04585
450	4,2	3,0	30	32	FT03	<b>LU1B 0600</b>	F03FS04586
500	4,4	3,2	30	36	FT03	<b>LU1B 0700</b>	F03FS04587
550	4,8	3,5	30	44	2/10/60	<b>LU1B 0800</b>	F03FS04588
600	5,2	4,0	30	48	FT03	<b>LU1B 0900</b>	F03FS04589
650	5,6	4,2	30	54	FT02	<b>LU1B 1000</b>	F03FS08324
700	5,6	4,2	30	60	2/10/60	<b>LU1B 1100</b>	F03FS05892

**GATECH**  
www.freud.rs

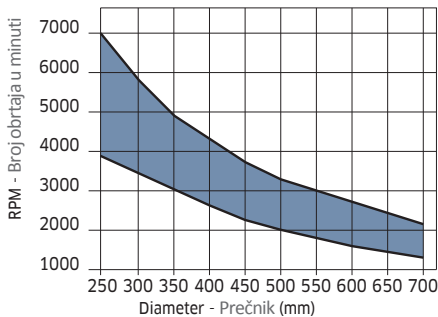

Minimum and maximum RPM based on the blade diameter.  
Minimalan i maksimalan broj obrtaja u odnosu na prečnik testere.

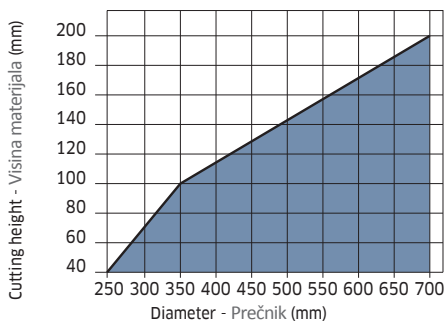

Maximum depth of cut based on the blade diameter.  
Maksimalna visina materijala koji se reže u odnosu na prečnik testere.

■ Solid wood  
Masiv

Ultimate Najbolja	High Odlična	Good Dobra
----------------------	-----------------	---------------

Ripping and cross cutting of softwood  
Uzdužno i poprečno rezanje mekog drveta  
Ripping and cross cutting of hardwood  
Uzdužno i poprečno rezanje tvrdog drveta

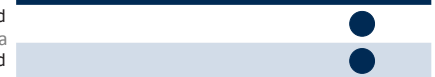

# LU1C

## HW - Saw blades to cut solid wood TM - Testere za rezanje masiva

Saw blades suitable for ripping.

**Machines:** Table saws, multiripping machines.

**Features:** ATB 10° tooth with positive cutting angle.

**Material:** Soft and hard solid wood, also with loose knots.

Testere za uzdužno rezanje.

**Mašine:** Stabilni cirkulari, višelisni cirkulari.

**Oblik zuba:** ATB 10° sa pozitivnim uglom rezanja.

**Materijal:** Meko i tvrdo drvo, može i sa čvorovima.

**FT01:** 2/7/42 + 2/9/46,4 + 2/10/60

**FT02:** 2/9/46,4 + 2/10/60

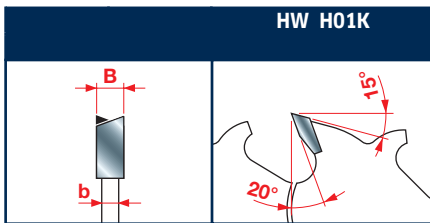

Tooth features - Karakteristike zuba

D	B	b	d	Z	NL - KN	Code	SAP
mm	mm	mm	mm		Pomoćni otvori	Šifra	SAP
250	3,2	2,2	30	22	FT01	LU1C 0100	F03FS04590
250	3,2	2,2	70	22	4CH 21x5	LU1C 0200	F03FS04592
300	3,2	2,2	30	26	FT01	LU1C 0400	F03FS04595
300	3,2	2,2	35	26		LU1C 0500	F03FS04597
300	3,2	2,2	70	26	4CH 21x5	LU1C 0700	F03FS04599
315	3,2	2,2	30	28	FT01	LU1C 0800	F03FS04601
350	3,5	2,5	30	30	FT02	LU1C 1000	F03FS04603
350	3,5	2,5	35	30		LU1C 1100	F03FS04605
350	3,5	2,5	70	30	4CH 21x5	LU1C 1200	F03FS04607
400	4,0	2,8	30	34	2/10/60	LU1C 1300	F03FS04609
450	4,4	3,0	30	38	2/10/60	LU1C 1400	F03FS04611
500	4,4	3,2	30	42	2/10/60	LU1C 1500	F03FS04612
550	4,4	3,5	30	48	2/10/60	LU1C 1600	F03FS04613

GATECH  
www.freud.rs

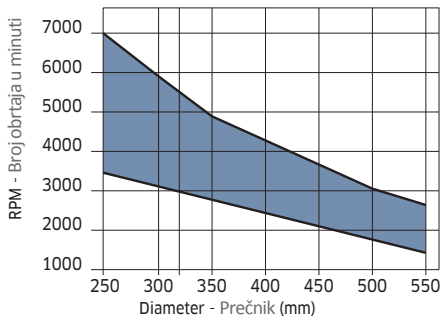

Minimum and maximum RPM based on the blade diameter.

Minimalan i maksimalan broj obrtaja u odnosu na prečnik testere.

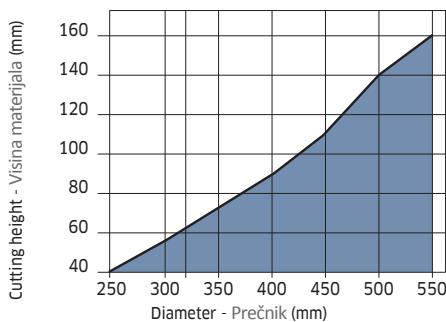

Maximum depth of cut based on the blade diameter.

Maksimalna visina materijala koji se reže u odnosu na prečnik testere.

■ Solid wood  
Masiv

Ultimate Najbolja	High Odlična	Good Dobra
----------------------	-----------------	---------------

Ripping of softwood  
Uzdužno rezanje mekog drveta

Ripping of hardwood  
Uzdužno rezanje tvrdog drveta

# LU1D

## HW - Saw blades to cut solid wood TM - Testere za rezanje masiva

Saw blades suitable for ripping.

**Machines:** Table saws, multiripping machines.

**Features:** ATB 10° tooth with positive cutting angle.

**Material:** Soft, hard and exotic solid wood without loose knots.

Testere za uzdužno rezanje.

**Mašine:** Stabilni cirkulari, višelisni cirkulari.

**Oblik zuba:** ATB 10° sa pozitivnim uglom rezanja.

**Materijal:** Meko, tvrdo i egzotično drvo bez čvorova.

**FT01:** 2/7/42 + 2/9/46,4 + 2/10/60

**FT02:** 2/9/46,4 + 2/10/60



D mm	B mm	b mm	d mm	Z	NL - KN Pomoćni otvori	Code Šifra	SAP SAP
250	3,2	2,2	30	24	FT01	LU1D 0100	F03FS04615
250	3,2	2,2	70	24	4CH 21x5	LU1D 0200	F03FS04617
300	3,2	2,2	30	28	FT01	LU1D 0500	F03FS04620
300	3,2	2,2	60	28	4CH 21x5	LU1D 0600	F03FS04622
300	3,2	2,2	70	28	4CH 21x5	LU1D 0800	F03FS04624
350	3,5	2,5	30	32	FT02	LU1D 1100	F03FS04628
350	3,5	2,5	70	32	4CH 21x5	LU1D 1000	F03FS04626

GATECH  
www.freud.rs

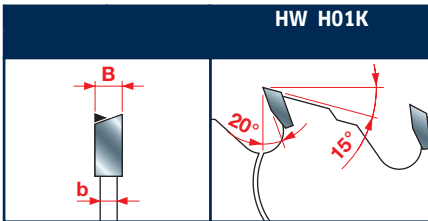

Tooth features - Karakteristike zuba

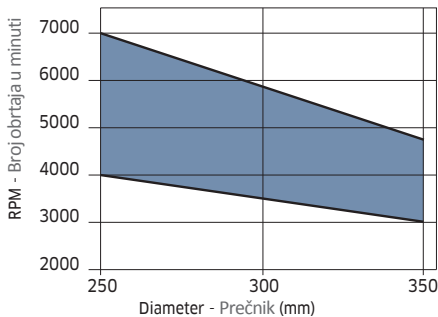

Minimum and maximum RPM based on the blade diameter.  
Minimalan i maksimalan broj obrtaja u odnosu na prečnik testere.

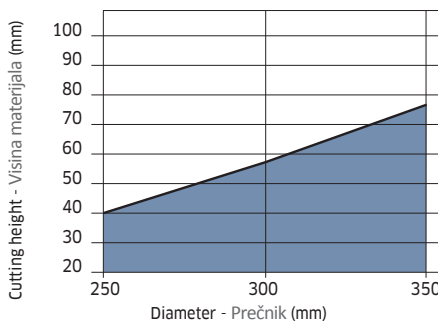

Maximum depth of cut based on the blade diameter.  
Maksimalna visina materijala koji se reže u odnosu na prečnik testere.

■ Solid wood  
Masiv

Ultimate Najbolja	High Odlična	Good Dobra
	●	
	●	

Ripping of softwood  
Uzdužno rezanje mekog drveta  
Ripping of hardwood  
Uzdužno rezanje tvrdog drveta

# LU1E

## HW - Saw blades to cut solid wood - Thin kerf TM - Testere za rezanje masiva - Uzak rez

Saw blades suitable for ripping. The reduced cutting height makes workpiece feeding easier.

**Machines:** Table saws, portable machines.

**Features:** Flat tooth with positive cutting angle and anti-kickback device.

**Material:** Soft and hard dried wood, also with loose knots.

Testere za uzdužno rezanje. Smanjena visina reza omogućava lakše ubacivanje komada.

**Mašine:** Stabilni cirkulari, ručni cirkulari.

**Oblik zuba:** Ravan sa pozitivnim uglom rezanja i sistemom protiv odskakanja.

**Materijal:** Meko i tvrdo suvo drvo, može i sa čvorovima.

**FT01:** 2/7/42 + 2/9/46,4 + 2/10/60

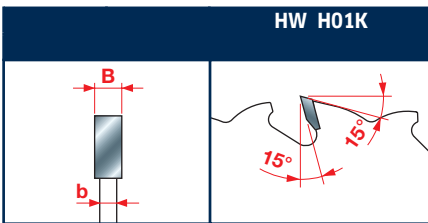

Tooth features - Karakteristike zuba

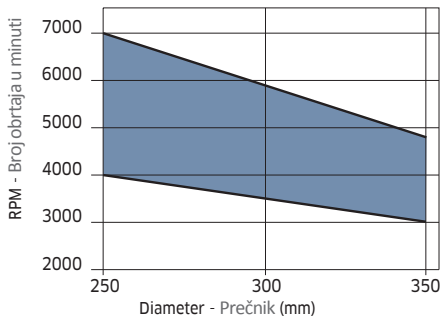

Minimum and maximum RPM based on the blade diameter.

Minimalan i maksimalan broj obrtaja u odnosu na prečnik testere.

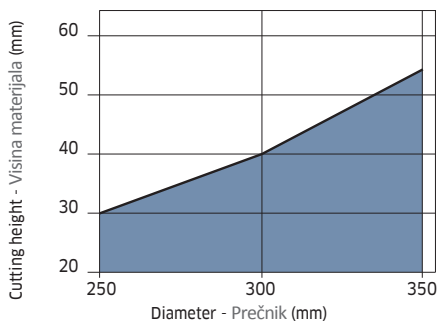

Maximum depth of cut based on the blade diameter.

Maksimalna visina materijala koji se reže u odnosu na prečnik testere.

■ Solid wood  
Masiv

D	B	b	d	Z	NL	Code	SAP
mm	mm	mm	mm		Pomoćni otvori	Šifra	SAP
250	2,5	1,6	30	24	FT01	LU1E 0100	F03FS04630
300	2,6	1,8	30	24		LU1E 0500	F03FS04638
300	2,7	1,8	25	28		LU1E 0200	F03FS04632
300	2,7	1,8	30	28	FT01	LU1E 0300	F03FS04634
350	3,0	2,2	30	32	FT01	LU1E 0400	F03FS04636

GATECH  
www.freud.rs

	Ultimate Najbolja	High Odlična	Good Dobra
Ripping of solid wood Uzdužno rezanje masiva		●	
Cross cutting of solid wood Poprečno rezanje masiva			●
Wood composites Drveni kompoziti			●

# LU1F

## HW - Saw blades to cut solid wood - Thin kerf

### TM- Testere za rezanje masiva - Uzak rez

Saw blades suitable for ripping. The reduced cutting height makes workpiece feeding easier.

**Machines:** Table saws, portable machines.

**Features:** ATB 10° tooth with positive cutting angle.

**Material:** Soft and hard dried wood, without loose knots.

Testere za uzdužno rezanje. Smanjena visina reza omogućava lakše ubacivanje komada.

**Mašine:** Stabilni cirkulari, ručni cirkulari.

**Oblik zuba:** ATB 10° sa pozitivnim uglom rezanja.

**Materijal:** Meko i tvrdo suvo drvo, bez čvorova.

**FT01:** 2/7/42 + 2/9/46,4 + 2/10/60



D mm	B mm	b mm	d mm	Z	NL Pomoćni otvori	Code Šifra	SAP SAP
250	2,5	1,6	30	24	FT01	LU1F 0100	F03FS04640
300	2,7	1,8	30	28	FT01	LU1F 0200	F03FS04642
350	3,0	2,2	30	32	FT01	LU1F 0300	F03FS04644

GATECH  
www.freud.rs

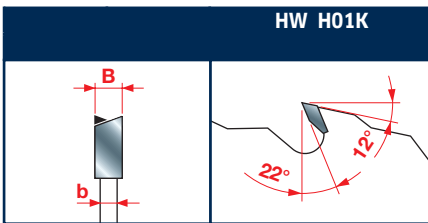

Tooth features - Karakteristike zuba

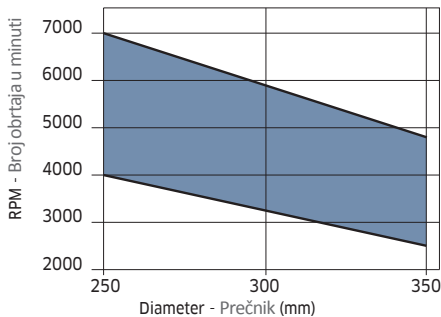

Minimum and maximum RPM based on the blade diameter.  
Minimalan i maksimalan broj obrtaja u odnosu na prečnik testere.

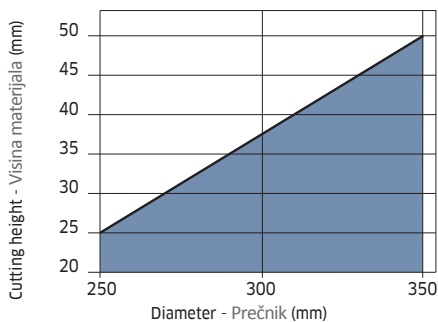

Maximum depth of cut based on the blade diameter.  
Maksimalna visina materijala koji se reže u odnosu na prečnik testere.

■ Solid wood  
■ Masiv

Ultimate Najbolja	High Odlična	Good Dobra
----------------------	-----------------	---------------

Ripping of softwood  
Uzdužno rezanje mekog drveta  
Ripping of hardwood  
Uzdužno rezanje tvrdog drveta

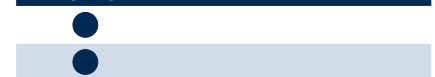



# LU1G

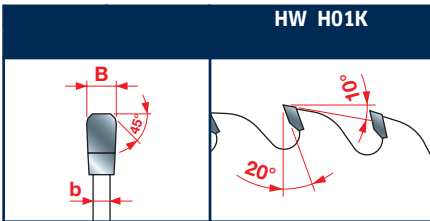

Tooth features - Karakteristike zuba

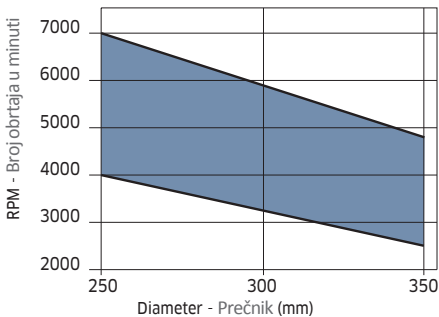

Minimum and maximum RPM based on the blade diameter.  
Minimalan i maksimalan broj obrtaja u odnosu na prečnik testere.

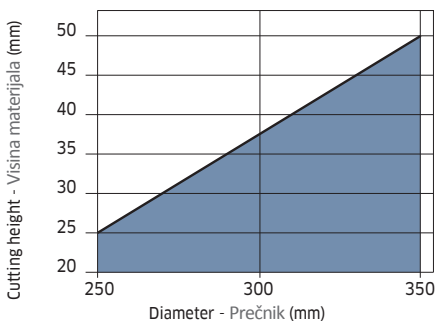

Maximum depth of cut based on the blade diameter.  
Maksimalna visina materijala koji se reže u odnosu na prečnik testere.

■ Solid wood  
Masiv

## HW - Saw blades to cut solid wood - rounded teeth on the side TM - Testere za rezanje masiva - ravan zub zaobljenih ivica

Saw blades suitable for ripping with fine cutting finish and without scratching, in order to achieve a perfectly smoothed surface.

**Machines:** Table saws.

**Features:** Straight tooth, rounded on the side, with positive cutting angle.

**Material:** Softwood.

Testere za uzdužno rezanje - za fini rez i završnu obradu bez grebanja.

**Mašine:** Stabilni cirkulari.

**Oblik zuba:** Ravan zub zaobljenih ivica, sa pozitivnim uglom rezanja.

**Materijal:** Meko drvo.

**FT01:** 2/7/42 + 2/9/46,4 + 2/10/60

D	B	b	d	Z	NL	Code	SAP
mm	mm	mm	mm		Pomoćni otvori	Šifra	SAP
250	3,0	2,0	30	40	FT01	LU1G 0100	F03FS04646
300	3,0	2,0	30	48	FT01	LU1G 0200	F03FS04647
350	3,2	2,2	30	60	FT01	LU1G 0300	F03FS04648

GATECH  
www.freud.rs

### Comparison between the cut of a conventional saw blade and a saw blade equipped with teeth that is rounded on the side.

Poređenje kvaliteta reza konvencionalne testere sa kvalitetom reza testere koja ima zub zaobljenih ivica.



Conventional saw blades  
Konvencionalne testere



LU1G saw blades  
LU1G testere

Ripping of softwood  
Uzdužno rezanje mekog drveta

Ultimate Najbolja	High Odlična	Good Dobra
●		

# LU1H

## HW - Saw blades to cut solid wood - Thin kerf TM - Testere za rezanje masiva - Uzak rez

Saw blades suitable for ripping and crosscutting. The reduced cutting height makes workpiece feeding easier.

**Machines:** Table saws, portable machines.

**Features:** ATB 15° tooth with positive cutting angle.

**Material:** Good quality, soft and hard solid wood.

Testere za uzdužno i poprečno rezanje. Smanjena visina reza omogućava lakše ubacivanje komada.

**Mašine:** Stabilni cirkulari, ručni cirkulari.

**Oblik zuba:** ATB 15° sa pozitivnim uglom rezanja.

**Materijal:** Kvalitetno meko i tvrdo drvo.

**FT01:** 2/7/42 + 2/9/46,4 + 2/10/60

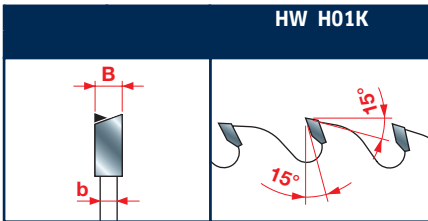

Tooth features - Karakteristike zuba

D mm	B mm	b mm	d mm	Z	NL Pomoćni otvori	Code Šifra	SAP SAP
180	1,5	1,0	30	40	2/7/42	LU1H 0100	F03FS04649
185	1,5	1,0	25,4	40		LU1H 0200	F03FS04650
200	1,5	1,0	30	40	2/7/42	LU1H 0300	F03FS07131
200	1,5	1,0	30	60	2/7/42	LU1H 0400	F03FS04651
205	1,5	1,0	25,4	40		LU1H 0500	F03FS04652
205	1,5	1,0	25,4	60		LU1H 0600	F03FS04653
250	2,5	1,6	30	48	FT01	LU1H 0700	F03FS04655
250	2,5	1,6	30	60	FT01	LU1H 0800	F03FS04657
250	2,8	2,0	30	30	2/10/60	LU1H 1500	F03FS04670
250	2,8	2,0	30	40	2/10/60	LU1H 1600	F03FS07127
300	2,8	2,0	30	36	FT01	LU1H 1400	F03FS04668
300	2,8	2,0	30	54	FT01	LU1H 0900	F03FS04659
300	2,8	2,0	35	54		LU1H 1000	F03FS04661
300	2,8	2,0	30	72	FT01	LU1H 1100	F03FS04663
350	3,0	2,2	30	60	FT01	LU1H 1200	F03FS04665
350	3,0	2,2	30	84	FT01	LU1H 1300	F03FS04667

GATECH  
www.freud.rs

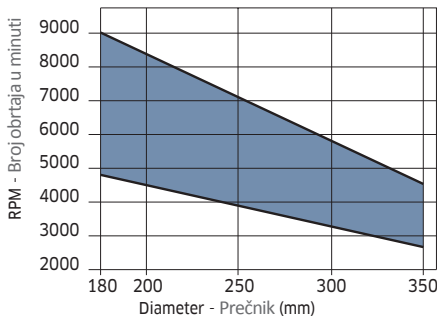

Minimum and maximum RPM based on the blade diameter.  
Minimalan i maksimalan broj obrtaja u odnosu na prečnik testere.

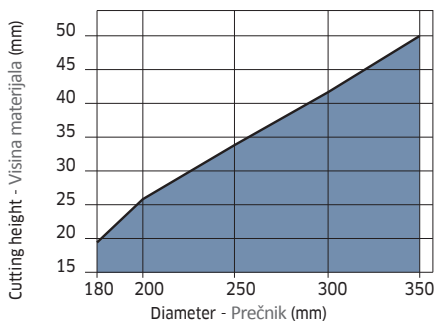

Maximum depth of cut based on the blade diameter.  
Maksimalna visina materijala koji se reže u odnosu na prečnik testere.

Solid wood  
Masiv

Ultimate Najbolja	High Odlična	Good Dobra
	●	
	●	
		●

Ripping and crosscutting of softwood  
Uzdužno i poprečno rezanje mekog drveta  
Ripping and crosscutting of hardwood  
Uzdužno i poprečno rezanje tvrdog drveta  
Wood composites  
Drveni kompoziti

# LU11

## HW - Saw blades to cut solid wood frames TM - Testere za rezanje ramova od masiva

Saw blades suitable for crosscutting. Without splintering frames and end trims of previously profiled items, where the items have to be coupled to perfectly match, even if they are covered with paint, chalk and other abrasive and fine materials.

**Machines:** Single or double-head miter saws.

**Features:** ATB 20° tooth with positive cutting angle.

**Material:** Soft and hardwood.

Testere za poprečno rezanje. Bez rastavljanja ramova i prethodnog pripremanja profila, kada je potrebno savršeno poklapanje, čak i u slučaju kada se na ramovima nalazi farba, kreda ili neki drugi abrazivni ili fini materijal.

**Mašine:** Obični ili dvoglavi gerovi.

**Oblik zuba:** ATB 20° sa pozitivnim uglom rezanja.

**Materijal:** Meko i tvrdo drvo.

**FT02:** 2/9/46,4 + 2/10/60

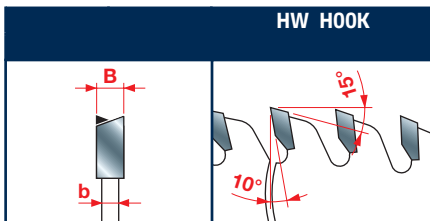
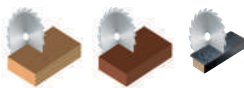

Tooth features - Karakteristike zuba

D mm	B mm	b mm	d mm	Z	NL Pomoćni otvori	Code Šifra	SAP SAP
200	2,95	2,5	30	64	2/7/42	LU11 0100	F03FS04673
250	2,95	2,5	20	80	2/6/32	LU11 0200	F03FS04675
250	2,95	2,5	30	80	FT02	LU11 0300	F03FS04677
250	2,95	2,5	30	96	FT02	LU11 0400	F03FS04679
275	2,95	2,5	20	84	2/6/32	LU11 0500	F03FS04681
300	2,95	2,5	30	96	FT02	LU11 0600	F03FS04682
300	2,95	2,5	30	112	FT02	LU11 0700	F03FS04684
330	3,45	3,0	30	96	FT02	LU11 0800	F03FS04686
350	3,45	3,0	30	108	FT02	LU11 0900	F03FS04688

GATECH  
www.freud.rs

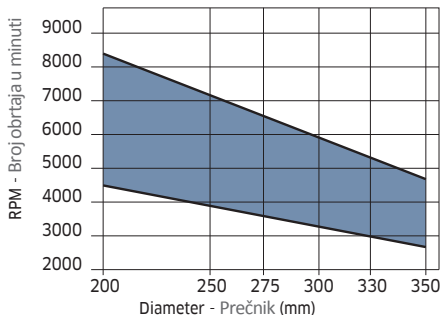

Minimum and maximum RPM based on the blade diameter.

Minimalan i maksimalan broj obrtaja u odnosu na prečnik testere.

Ultimate Najbolja	High Odlična	Good Dobra
	●	

Frames  
Ramovi

# LU1L

## HW - Saw blades to cut solid wood frames TM - Testere za rezanje ramova od masiva

Suitable for crosscutting. High-performance saw blades, with excellent cut and without splintering; finished and perfectly smooth surface, which is specifically recommended for frames' and profiles' end trims whose front-end cut keeps visible.

**Machines:** Single or double-head miter saws.

**Features:** Flat - ATB 10° tooth with axial 15° and positive cutting angle.

**Material:** Soft and hardwood.

Testere za poprečno rezanje. Testere vrhunskih performansi, sa odličnim kvalitetom reza bez cepanja ramova; završni rez je savršeno gladak, što je posebno važno kod ramova kod kojih je prednji deo reza vidljiv.

**Mašine:** Obični ili dvoglavi gerovi.

**Oblik zuba:** ATB 10° zub sa aksijalnim 15° i pozitivnim uglom rezanja.

**Materijal:** Meko i tvrdo drvo.

**FT01:** 2/7/42 + 2/9/46,4 + 2/10/60

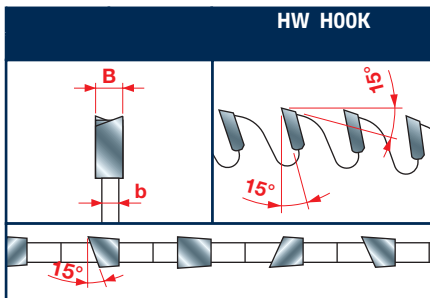
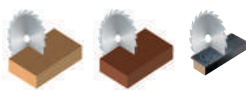
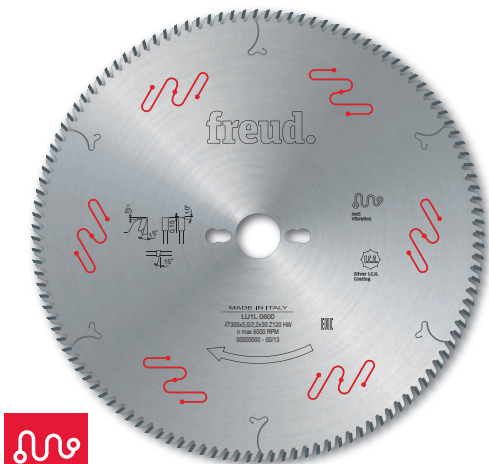

Tooth features - Karakteristike zuba

D mm	B mm	b mm	d mm	Z	NL Pomoćni otvori	Code Šifra	SAP SAP
250	3,0	2,2	30	100	FT01	LU1L 0100	F03FS04690
250	3,0	2,2	30	120	FT01	LU1L 0200	F03FS04691
255	3,0	2,2	25,4	100		LU1L 0300	F03FS04692
255	3,0	2,2	25,4	120		LU1L 0400	F03FS04693
300	3,0	2,2	30	100	FT01	LU1L 0500	F03FS04694
300	3,0	2,2	30	120	FT01	LU1L 0600	F03FS04695
305	3,0	2,2	25,4	100		LU1L 0700	F03FS04696
305	3,0	2,2	25,4	120		LU1L 0800	F03FS04697
305	3,0	2,2	30	100		LU1L 1100	F03FS06410
350	3,0	2,2	30	120	FT01	LU1L 0900	F03FS04698
355	3,0	2,2	25,4	120		LU1L 1000	F03FS04699

GATECH  
www.freud.rs

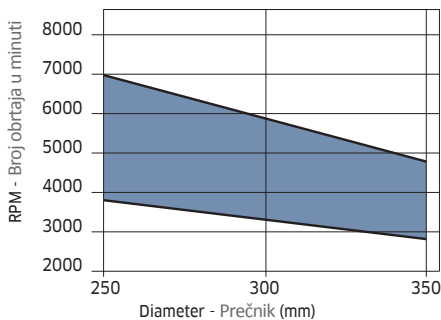

Minimum and maximum RPM based on the blade diameter.  
Minimalan i maksimalan broj obrtaja u odnosu na prečnik testere.

Ultimate  
Najbolja

High  
Odlična

Good  
Dobra

Frames  
Ramovi



# LU2A

## HW - Saw blades to cut wooden panels and composites TM - Testere za rezanje drveta i kompozitnih materijala

Saw blades suitable to ripping and crosscutting.

**Machines:** Circular saws, portable machines.

**Features:** ATB tooth with positive cutting angle.

**Material:** Soft and hard solid wood, unprocessed chipboard and plywood.

Testere za uzdužno i poprečno rezanje.

**Mašine:** Stabilni i ručni cirkularni.

**Oblik zuba:** ATB sa pozitivnim uglom rezanja.

**Materijal:** Meko i tvrdo drvo, neobrađena iverica i šper.

**FT01:** 2/7/42 + 2/9/46,4 + 2/10/60

**FT02:** 2/9/46,4 + 2/10/60

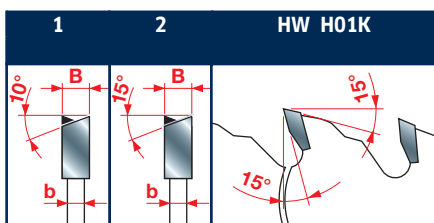
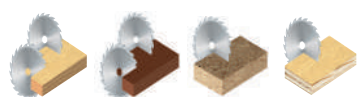

Tooth features - Karakteristike zuba

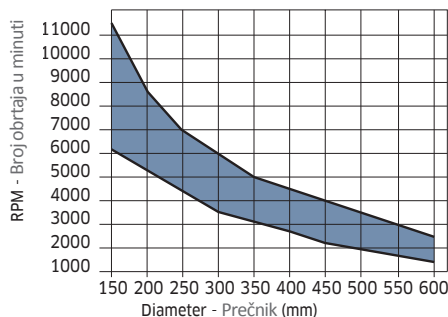

Minimum and maximum RPM based on the blade diameter.

Minimalan i maksimalan broj obrtaja u odnosu na prečnik testere.

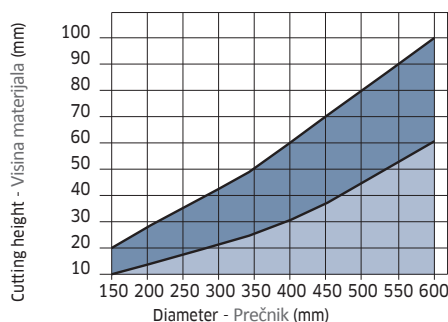

Maximum depth of cut based on the blade diameter.  
Maksimalna visina materijala koji se reže u odnosu na prečnik testere.

■ Solid wood  
Masiv

■ Wood-base materials  
Drveni kompoziti

### ATB 10° tooth (Fig. 1) - ATB 10° zub (Opcija 1)

D	B	b	d	Z	NL	Code	SAP
mm	mm	mm	mm		Pomoćni otvori	Šifra	SAP
150	3,2	2,2	30	24	2/7/42	LU2A 0100	F03FS04806
160	3,2	2,2	20	24	2/6/32	LU2A 0300	F03FS04809
180	3,2	2,2	30	30	2/7/42	LU2A 0500	F03FS04811
190	3,2	2,2	30	30	2/7/42	LU2A 0600	F03FS04813
200	3,2	2,2	30	34	2/7/42	LU2A 0800	F03FS04817
200	3,2	2,2	35	34		LU2A 0900	F03FS04819
210	3,2	2,2	30	34	2/7/42	LU2A 1100	F03FS04822
216	3,2	2,2	30	34		LU2A 1200	F03FS04823
220	3,2	2,2	30	34	2/7/42	LU2A 1300	F03FS04824
230	3,2	2,2	30	34	2/7/42	LU2A 1500	F03FS04827
250	3,2	2,2	30	40	FT01	LU2A 1700	F03FS04830
250	3,2	2,2	35	40		LU2A 1800	F03FS04832
300	3,2	2,2	30	48	FT01	LU2A 2100	F03FS04840
300	3,2	2,2	35	48		LU2A 2300	F03FS04843
315	3,2	2,2	30	48	FT01	LU2A 2400	F03FS04844
350	3,5	2,5	30	54	FT02	LU2A 2800	F03FS04849
350	3,5	2,5	35	54		LU2A 3000	F03FS04851
400	4,0	2,8	30	60	2/10/60	LU2A 3300	F03FS04856
400	4,0	2,8	35	60		LU2A 3400	F03FS04858
450	4,4	3,0	30	66	2/10/60	LU2A 3600	F03FS04862
500	4,4	3,2	30	72	2/10/60	LU2A 3800	F03FS04865
550	4,8	3,5	30	84	2/10/60	LU2A 3900	F03FS04867
600	5,4	4,0	30	96	2/10/80	LU2A 4000	F03FS04868
735	6,0	4,4	30	72	2/8,5/90	LU2A 4200	F03FS05908
760	6,2	4,5	30	72	2/8,5/90	LU2A 4300	F03FS05903

### ATB 15° tooth (Fig. 2) - ATB 15° zub (Opcija 2)

D	B	b	d	Z	NL	Code	SAP
mm	mm	mm	mm		FT	Šifra	SAP
160	3,2	2,2	20	18	2/6/32	LU2A 0200	F03FS04808
180	3,2	2,2	20	24	2/6/32	LU2A 0400	F03FS04810
200	3,2	2,2	30	24	2/7/42	LU2A 0700	F03FS04814
210	3,2	2,2	30	24	2/7/42	LU2A 1000	F03FS04821
230	3,2	2,2	30	24	2/7/42	LU2A 1400	F03FS04826
250	3,2	2,2	30	30	FT01	LU2A 1600	F03FS04828
300	3,2	2,2	30	36	FT01	LU2A 1900	F03FS04834
350	3,5	2,5	30	42	FT02	LU2A 2500	F03FS04845
350	3,5	2,5	35	42		LU2A 2600	F03FS04847
400	4,0	2,8	30	48	2/10/60	LU2A 3100	F03FS04853
450	4,4	3,0	30	54	2/10/60	LU2A 3500	F03FS04860
500	4,4	3,2	30	60	2/10/60	LU2A 3700	F03FS04864

Ultimate Najbolja High Odlična Good Dobra

Ripping of solid wood  
Uzdužno rezanje masiva  
Crosscutting of solid wood  
Poprečno rezanje masiva  
Wood composites  
Drveni kompoziti



GATECH  
www.freud.rs



## HW - Saw blades to cut wooden panels and composites TM - Testere za rezanje drveta i kompozitnih materijala

Saw blades suitable for ripping and crosscutting.

**Machines:** Circular saws, portable machines.

**Features:** ATB 15° tooth with positive cutting angle.

**Material:** Soft, hard and exotic solid wood, unprocessed chipboard and plywood.

Testere za uzdužno i poprečno rezanje.

**Mašine:** Stabilni i ručni cirkulari.

**Oblik zuba:** ATB 15° sa pozitivnim uglom rezanja.

**Materijal:** Meko, tvrdo i egzotično drvo, sirova iverica i šper.

**FT01:** 2/7/42 + 2/9/46,4 + 2/10/60

**FT02:** 2/9/46,4 + 2/10/60

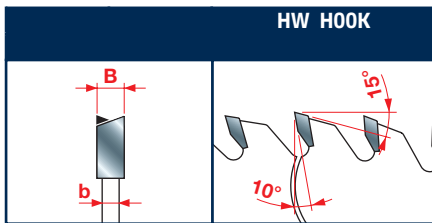
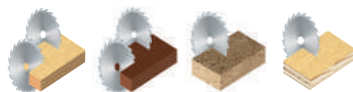
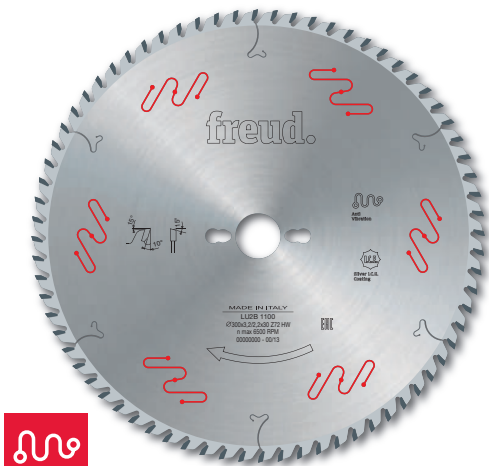

Tooth features - Karakteristike zuba

D	B	b	d	Z	NL	Code	SAP
mm	mm	mm	mm		Pomoćni otvori	Šifra	SAP
150	3,2	2,2	30	36	2/7/42	LU2B 0100	F03FS04869
180	3,2	2,2	30	42	2/7/42	LU2B 0200	F03FS04871
200	3,2	2,2	30	48	2/7/42	LU2B 0300	F03FS04873
216	3,2	2,2	30	48		LU2B 0400	F03FS04876
250	3,2	2,2	30	48	FT01	LU2B 0500	F03FS04877
250	3,2	2,2	30	60	FT01	LU2B 0700	F03FS04880
250	3,2	2,2	35	60		LU2B 0800	F03FS04882
300	3,2	2,2	30	60	FT01	LU2B 0900	F03FS04884
300	3,2	2,2	30	72	FT01	LU2B 1100	F03FS04887
300	3,2	2,2	35	72		LU2B 1200	F03FS04889
315	3,2	2,2	30	72	FT01	LU2B 1300	F03FS04891
350	3,5	2,5	30	72	FT02	LU2B 1400	F03FS04893
350	3,5	2,5	30	84	FT02	LU2B 1600	F03FS04895
350	3,5	2,5	35	84		LU2B 2400	F03FS04905
400	4,0	2,8	30	96	2/10/60	LU2B 1900	F03FS04897
450	4,4	3,0	30	96	2/10/60	LU2B 2000	F03FS04899
500	4,4	3,2	30	108	2/10/60	LU2B 2100	F03FS04901
550	4,8	3,5	30	120	2/10/60	LU2B 2200	F03FS04903
600	5,4	4,0	30	132	2/10/80	LU2B 2300	F03FS04904

GATECH  
www.freud.rs

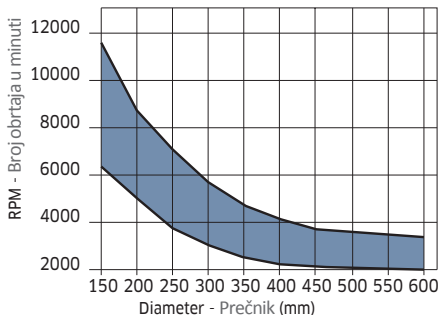

Minimum and maximum RPM based on the blade diameter.  
Minimalan i maksimalan broj obrtaja u odnosu na prečnik testere.

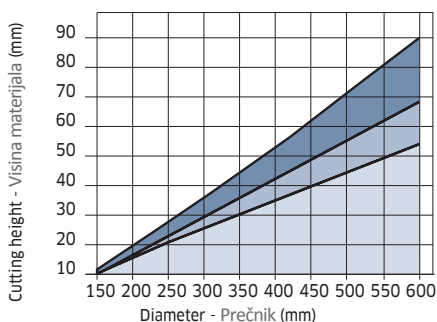

Maximum depth of cut based on the blade diameter.  
Maksimalna visina materijala koji se reže u odnosu na prečnik testere.

Solid wood / Masiv  
 Wood-base materials / Drveni kompoziti  
 Plywood / Furnir

	Ultimate Najbolja	High Odlična	Good Dobra
Ripping of solid wood Uzdužno rezanje masiva	●	●	●
Crosscutting of solid wood Poprečno rezanje masiva	●	●	●
Wood composites Drveni kompoziti	●	●	●

## HW - Saw blades to cut wooden panels and composites TM - Testere za rezanje drveta i kompozitnih materijala

Saw blades suitable for crosscutting.

**Machines:** Circular saws, portable machines.

**Features:** ATB 15° tooth with positive cutting angle.

**Material:** Soft, hard and exotic solid wood, chipboard, thermoplastic-wood composites, MDF laminated on one side.

Testere za uzdužno i poprečno rezanje.

**Mašine:** Stabilni i ručni cirkulari.

**Oblik zuba:** ATB 15° sa pozitivnim uglom rezanja.

**Materijal:** Meko, tvrdo i egzotično drvo, iverica, drveni kompoziti sa termoplastičnom folijom, medijapan (MDF) laminiran sa jedne strane.

**FT01:** 2/7/42 + 2/9/46,4 + 2/10/60

**FT02:** 2/9/46,4 + 2/10/60

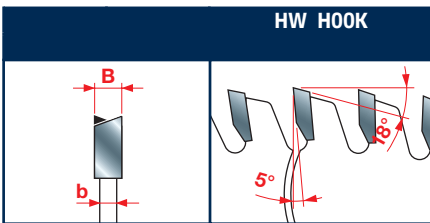
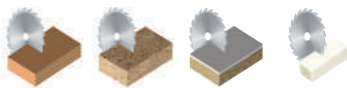

Tooth features - Karakteristike zuba

D	B	b	d	Z	NL	Code	SAP
mm	mm	mm	mm		Pomoćni otvori	Šifra	SAP
150	3,2	2,2	30	48	2/7/42	LU2C 0100	F03FS04908
160	3,2	2,2	20	48	2/6/32	LU2C 0200	F03FS04910
180	3,2	2,2	20	56	2/6/32	LU2C 0300	F03FS04911
180	3,2	2,2	30	56	2/7/42	LU2C 0400	F03FS04912
190	3,2	2,2	30	56	2/7/42	LU2C 0500	F03FS04914
200	3,2	2,2	30	64	2/7/42	LU2C 0600	F03FS04915
210	3,2	2,2	30	64	2/7/42	LU2C 0700	F03FS04917
216	3,2	2,2	30	64	2/7/42	LU2C 0800	F03FS04918
220	3,2	2,2	30	64	2/7/42	LU2C 0900	F03FS04919
230	3,2	2,2	30	64	2/7/42	LU2C 1000	F03FS04921
250	3,2	2,2	30	80	FT01	LU2C 1200	F03FS04922
250	3,2	2,2	30	100	FT01	LU2C 1300	F03FS04924
300	3,2	2,2	30	96	FT01	LU2C 1500	F03FS04927
300	3,2	2,2	35	96		LU2C 1600	F03FS04930
300	3,2	2,2	30	120	FT01	LU2C 1700	F03FS04932
330	3,2	2,2	20	96	2/6/32	LU2C 1800	F03FS04934
350	3,5	2,5	30	108	FT02	LU2C 2000	F03FS04936
400	3,8	2,8	30	120	2/10/60	LU2C 2100	F03FS04938
450	4,4	3,0	30	132	FT02	LU2C 2200	F03FS04939
500	4,4	3,2	30	144	2/10/60	LU2C 2300	F03FS04940
550	4,8	3,5	30	156	2/10/60	LU2C 2400	F03FS04942
600	5,4	4,0	30	168	2/10/80	LU2C 2500	F03FS04943

GATECH  
www.freud.rs

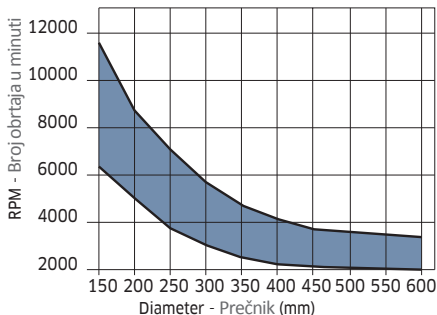

Minimum and maximum RPM based on the blade diameter.  
Minimalan i maksimalan broj obrtaja u odnosu na prečnik testere.

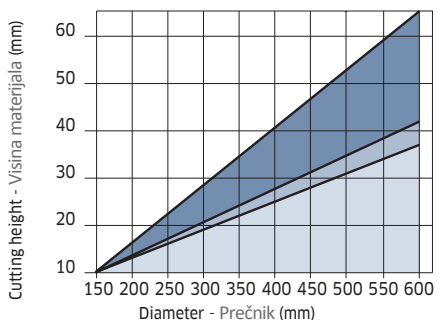

Maximum depth of cut based on the blade diameter.  
Maksimalna visina materijala koji se reže u odnosu na prečnik testere.

Solid wood / Masiv  
 Wood-base materials / Drveni kompoziti  
 Plywood / Furnir

	Ultimate Najbolja	High Odlična	Good Dobra
Crosscutting of solid wood Poprečno rezanje masiva	●		
Wood composites Drveni kompoziti	●		
Plastic materials Plastični materijali		●	

## HW - Saw blades to cut wooden panels and composites - Thin kerf

## TM - Testere za rezanje drveta i kompozitnih materijala - Uzak rez

Saw blades suitable for crosscutting. The reduced cutting height makes work-piece feeding easier.

**Machines:** Circular saws, portable machines.

**Features:** ATB 15° tooth with positive cutting angle.

**Material:** Soft, hard and exotic solid wood, chipboard, thermoplastic-wood composites, MDF laminated on one side.

Testere za poprečno rezanje. Smanjena visina reza omogućava lakše ubacivanje komada.

**Mašine:** Stabilni i ručni cirkulari.

**Oblik zuba:** ATB 15° sa pozitivnim uglom rezanja.

**Materijal:** Meko, tvrdo i egzotično drvo, iverica, drveni kompoziti sa termoplastičnom folijom, medijapan (MDF) jednostrano oplemenjen.

**FT01:** 2/7/42 + 2/9/46,4 + 2/10/60

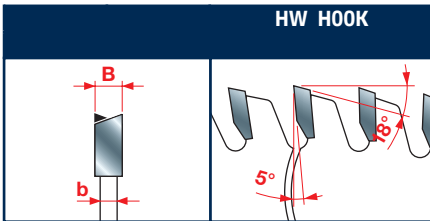
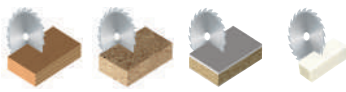
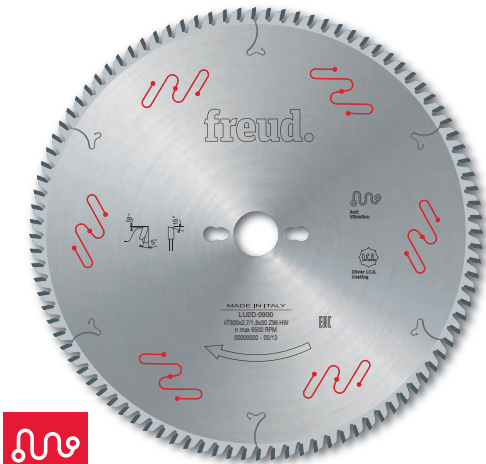

Tooth features - Karakteristike zuba

D	B	b	d	Z	NL	Code	SAP
mm	mm	mm	mm		Pomoćni otvori	Šifra	SAP
150	2,0	1,4	30	48	2/7/42	LU2D 0100	F03FS04944
180	2,0	1,4	30	56	2/7/42	LU2D 0200	F03FS04948
180	2,0	1,4	40	56		LU2D 0300	F03FS04950
200	2,2	1,6	30	64	2/7/42	LU2D 0400	F03FS04952
250	2,5	1,8	20	80	2/6/32	LU2D 0500	F03FS04954
250	2,5	1,8	30	80	FT01	LU2D 0700	F03FS04957
300	2,7	1,8	30	96	FT01	LU2D 0900	F03FS04959
350	3,0	2,2	30	108	FT01	LU2D 1100	F03FS04963

GATECH  
www.freud.rs

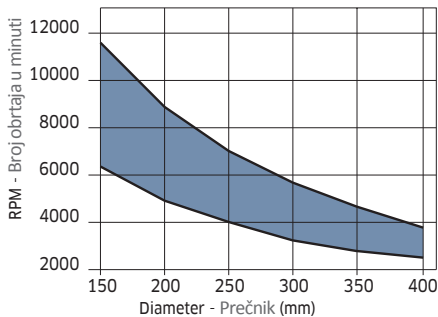

Minimum and maximum RPM based on the blade diameter.  
Minimalan i maksimalan broj obrtaja u odnosu na prečnik testere.

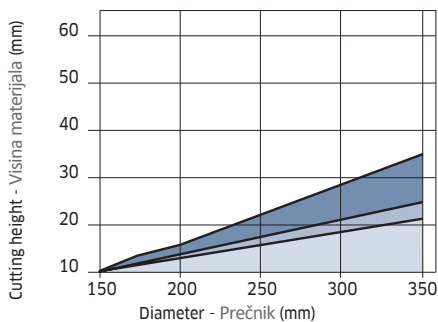

Maximum depth of cut based on the blade diameter.  
Maksimalna visina materijala koji se reže u odnosu na prečnik testere.

Solid wood / Masiv  
 Wood-base materials / Drveni kompoziti  
 Plywood / Furnir

	Ultimate Najbolja	High Odlična	Good Dobra
Crosscutting of solid wood Poprečno rezanje masiva	●		
Wood composites Drveni kompoziti	●		
Plastic materials Plastični materijali		●	

## HW - Saw blades to cut exotic abrasive wood and panels TM - Testere za rezanje poroznog egzotičnog drveta i pločastih materijala

Saw blades suitable for crosscutting.

**Machines:** Circular saws, panel-sizing machines.

**Features:** ATB 15° tooth with positive cutting angle.

**Material:** Good quality soft and hardwood, up to 50 mm chipboard, MDF laminated on one side, up to 30 mm.

Testere za poprečno rezanje.

**Mašine:** Stabilni cirkulari, formatizeri.

**Oblik zuba:** ATB 15° sa pozitivnim uglom rezanja.

**Materijal:** Kvalitetno meko i tvrdo drvo, iverica debljine do 50mm, medijapan (MDF) jednostrano oplemenjen, debljine do 30mm.

**FT01:** 2/7/42 + 2/9/46,4 + 2/10/60

**FT02:** 2/9/46,4 + 2/10/60

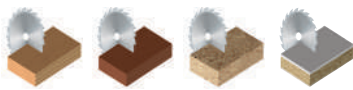

GATECH  
www.freud.rs

D mm	B mm	b mm	d mm	Z	NL Pomoćni otvori	Code Šifra	SAP SAP
300	3,2	2,2	30	60	FT01	LU2E 0200	F03FS04965
300	3,2	2,2	30	72	FT01	LU2E 0400	F03FS04967
350	3,5	2,5	30	72	FT02	LU2E 0500	F03FS04970

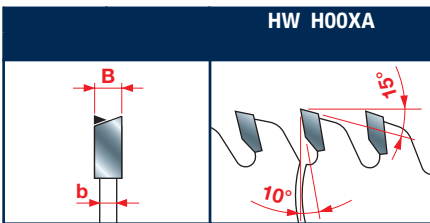

Tooth features - Karakteristike zuba

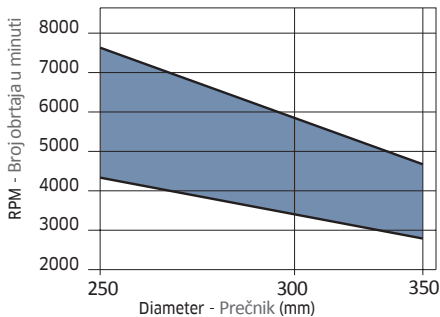

Minimum and maximum RPM based on the blade diameter.

Minimalan i maksimalan broj obrtaja u odnosu na prečnik testere.

- Solid wood  
Masiv
- Wood-base materials  
Drveni kompoziti
- Plywood  
Furnir

Crosscutting of soft and hardwood  
Poprečno rezanje masiva  
Wood composites  
Drveni kompoziti



# LU2F

## HW - Saw blades to cut wooden panels, composites and plastic materials

## TM - Testere za rezanje drveta, kompozitnih i plastičnih materijala

To size bilaminated panels without the employment of the scoring saw blade, with good finishing and long cutting life.

**Machines:** Circular saws, horizontal panel sizing machines, portable machines.

**Features:** ATB 10° tooth with negative cutting angle.

**Material:** Bilaminated panels with abrasive and hard coatings.

Testere za rezanje obostrano laminiranih pločastih materijala bez upotrebe predrezača.

**Mašine:** Stabilni cirkulari, horizontalni formatizeri, ručni cirkulari.

**Oblik zuba:** ATB 10° sa negativnim uglom rezanja.

**Materijal:** Obostrano oplemenjeni pločasti materijali sa poroznom i tvrdom folijom.

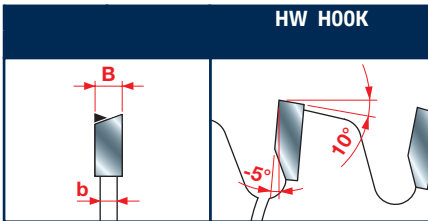
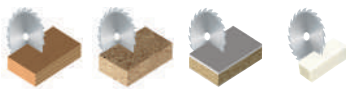

Tooth features - Karakteristike zuba

D	B	b	d	Z	Code	SAP
mm	mm	mm	mm		Šifra	SAP
216	2,8	2,0	30	24	LU2F 0100	F03FS06304
216	2,8	2,0	30	48	LU2F 0200	F03FS04971
216	2,8	2,0	30	60	LU2F 0300	F03FS04972
250	2,8	2,0	30	48	LU2F 0400	F03FS04973
250	2,8	2,0	30	60	LU2F 0500	F03FS04974

GATECH  
www.freud.rs

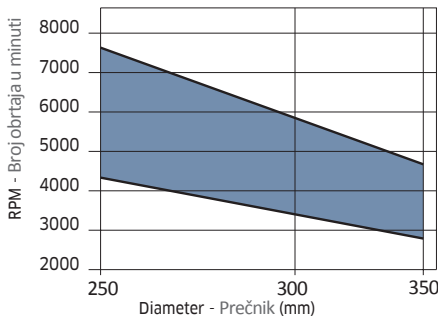

Minimum and maximum RPM based on the blade diameter.  
Minimalan i maksimalan broj obrtaja u odnosu na prečnik testere.

Solid wood  
Masiv
  Wood-base materials  
Drveni kompoziti
  Plywood  
Furnir

	Ultimate Najbolja	High Odlična	Good Dobra
Crosscutting of solid wood Poprečno rezanje masiva	●		
Wood composites Drveni kompoziti	●		
Plastic materials Plastični materijali		●	



## HW - Saw blades to cut bilaminated panels TM - Testere za rezanje obostrano oplemenjenih pločastih materijala

To size bilaminated panels, with perfect finishing on both sides without the employment of the scoring saw blade.

**Machines:** Circular vertical saws, panel-sizing machines, portable machines.

**Features:** ATB 38° tooth, with variable cutting angle according to the diameter.

**Material:** Bilaminated panels with extremely fine coatings, veneered panels.

Testere za rezanje obostrano oplemenjenih pločastih materijala, sa savršenim završnim rezom sa obe strane bez upotrebe predrezača.

**Mašine:** Stabilni vertikalni cirkulari, formatizeri, ručni cirkulari.

**Oblik zuba:** ATB 38°, sa promenljivim uglom rezanja u zavisnosti od dijametra.

**Materijal:** Obostrano oplemenjeni pločasti materijali sa ekstremno finom folijom, ploče od furnira.

**FT01:** 2/7/42 + 2/9/46,4 + 2/10/60

**FT02:** 2/9/46,4 + 2/10/60

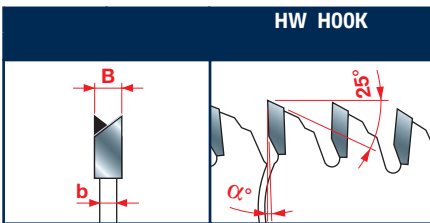
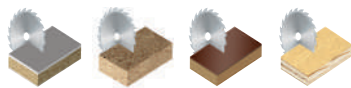

Tooth features - Karakteristike zuba

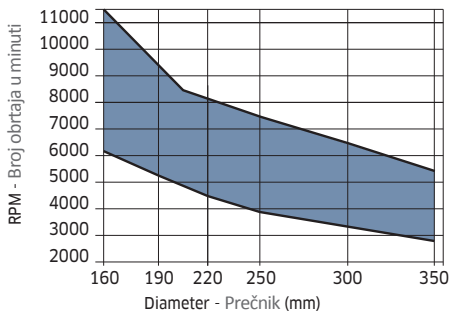

Minimum and maximum RPM based on the blade diameter.

Minimalan i maksimalan broj obrtaja u odnosu na prečnik testere.

### Working with spindle under the working plane Rad sa osovinom ispod radnog stola

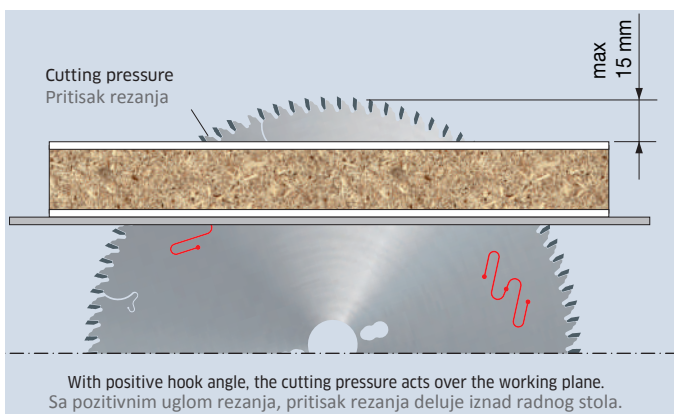

With positive hook angle, the cutting pressure acts over the working plane.  
Sa pozitivnim uglom rezanja, pritisak rezanja deluje iznad radnog stola.

Ultimate Najbolja	High Odlična	Good Dobra
●	●	●

Wood composites  
Drveni kompoziti  
Laminates  
Laminati

	D mm	B mm	b mm	d mm	Z	α	NL Pomoćni otvori	Code Šifra	SAP SAP
novi	160	2,2	1,6	20	48	-2°		LU3A 0001	F03FS07411
novi	190	2,5	1,8	30	48	-2°		LU3A 0002	F03FS07412
novi	210	2,5	1,8	30	54	-2°		LU3A 0003	F03FS07413

	D mm	B mm	b mm	d mm	Z	α	NL Pomoćni otvori	Code Šifra	SAP SAP
	220	3,2	2,2	30	64	-5°	2/7/42	LU3A 0100	F03FS05059
	250	3,2	2,2	30	80	-2°	FT01	LU3A 0200	F03FS05061
	300	3,2	2,2	25,4	96	2°		LU3A 0600	F03FS05807
	300	3,2	2,2	30	96	2°	FT01	LU3A 0300	F03FS05064
	350	3,5	2,5	30	108	5°	FT02	LU3A 0400	F03FS05066

GATECH  
www.freud.rs

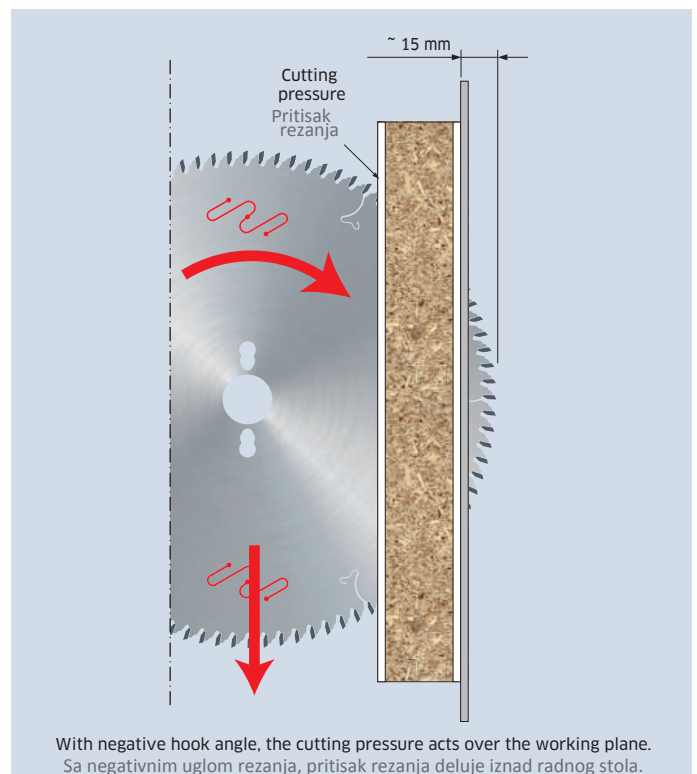
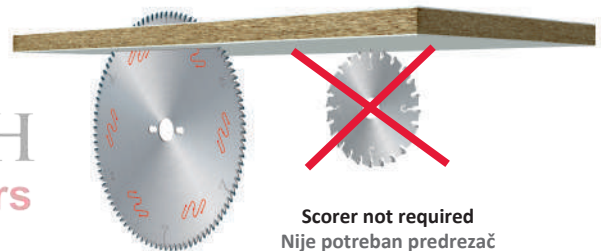

With negative hook angle, the cutting pressure acts over the working plane.  
Sa negativnim uglom rezanja, pritisak rezanja deluje iznad radnog stola.



# LU3B

## HW - Saw blades to cut bilaminated panels

## TM - Testere za rezanje obostrano oplemenjenih pločastih materijala

To size bilaminated panels without the employment of the scoring saw blade, with good finishing and long cutting life.

**Machines:** Circular saws, vertical machines without the scoring saw blade.

**Features:** Concave tooth with positive cutting angle.

**Material:** Bilaminated panels with abrasive and hard coatings.

Testere za rezanje obostrano oplemenjenih pločastih materijala bez upotrebe predrezača, sa dobrim završnim rezom i dugim radnim vekom.

**Mašine:** Stablni cirkulari, vertikalne mašine bez predrezača.

**Oblik zuba:** Konkavni sa pozitivnim uglom rezanja.

**Materijal:** Obostrano oplemenjeni pločasti materijali sa poroznom ili tvrdom folijom.

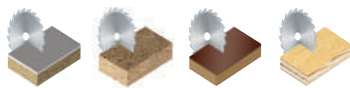
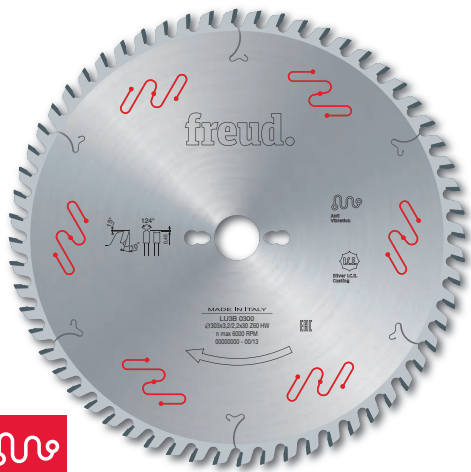

**FT01:** 2/7/42 + 2/9/46,4 + 2/10/60

D	B	b	d	Z	NL	Code	SAP
mm	mm	mm	mm		Pomoćni otvori	Šifra	SAP
220	3,2	2,2	30	42	2/7/42	LU3B 0100	F03FS05069
250	3,2	2,2	30	48	FT01	LU3B 0200	F03FS05071
303	3,2	2,2	30	60	FT01	LU3B 0300	F03FS05073
350	3,2	2,2	30	72	FT01	LU3B 0400	F03FS05075

D	B	b	d	Z	NL	Code	SAP
mm	mm	mm	mm		Pomoćni otvori	Šifra	SAP
303	3,2	2,2	30	60	FT01	LU3B 1300	F03FS06478

**Features:** Flat - triple chip tooth with concave face and positive cutting angle.

Karakteristike zuba: Ravan - trapezni zub sa konkavnim vrhom i pozitivnim uglom rezanja.

GATECH  
www.freud.rs

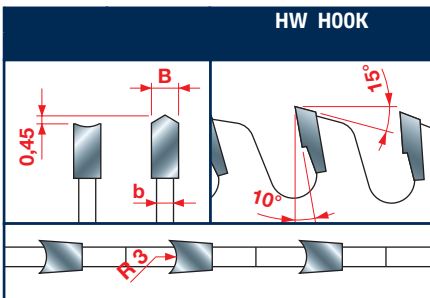

Tooth features - Karakteristike zuba

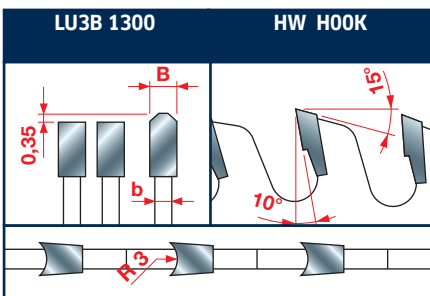

Tooth features - Karakteristike zuba

### Working with spindle over the working plane Rad sa osovinom iznad radnog stola

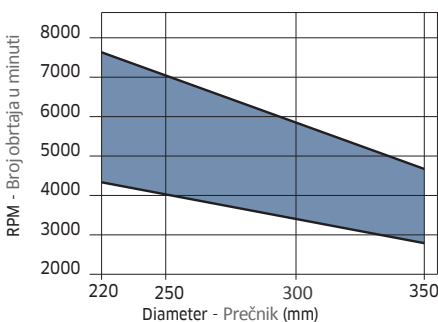
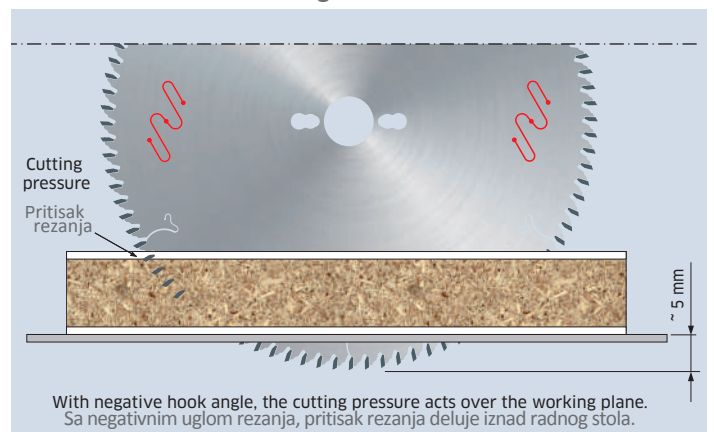

Minimum and maximum RPM based on the blade diameter.  
Minimalan i maksimalan broj obrtaja u odnosu na prečnik testere.

	Ultimate Najbolja	High Odlična	Good Dobra
Wood composites Drveni kompoziti	●		
Veneered Furnir	●	●	
Laminates Laminati	●	●	●

# LU3C

## HW - Saw blades to cut bilaminated panels TM - Testere za rezanje obostrano oplemenjenih pločastih materijala

To size bilaminated panels without the employment of the scoring saw blade, with good finishing and long cutting life.

**Machines:** Circular saws, horizontal and vertical machines without the scoring saw blade.

**Features:** Concave tooth with negative cutting angle.

**Material:** Bilaminated panels with abrasive and hard coatings.

Testere za rezanje obostrano oplemenjenih pločastih materijala bez upotrebe predrezača, sa dobrim završnim rezom i dugim radnim vekom.

**Mašine:** Stabilni cirkulari, vertikalne mašine bez predrezača.

**Oblik zuba:** Konkavni sa negativnim uglom rezanja.

**Materijal:** Obostrano oplemenjeni pločasti materijali sa poroznom ili tvrdom folijom.

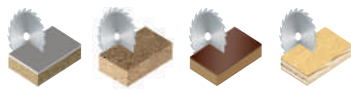

**FT01:** 2/7/42 + 2/9/46,4 + 2/10/60

D	B	b	d	Z	NL	Code	SAP
mm	mm	mm	mm		Pomoćni otvori	Šifra	SAP
220	3,2	2,2	30	42	2/7/42	LU3C 0100	F03FS05076
250	3,2	2,2	30	48	FT01	LU3C 0200	F03FS05077
303	3,2	2,2	30	60	FT01	LU3C 0300	F03FS05078
350	3,2	2,2	30	72	FT01	LU3C 0400	F03FS05080

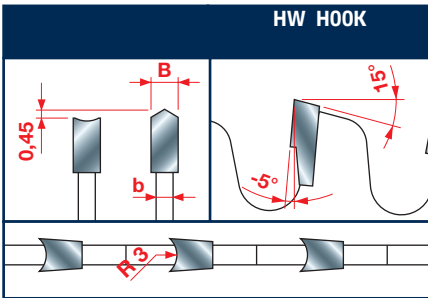

Tooth features - Karakteristike zuba

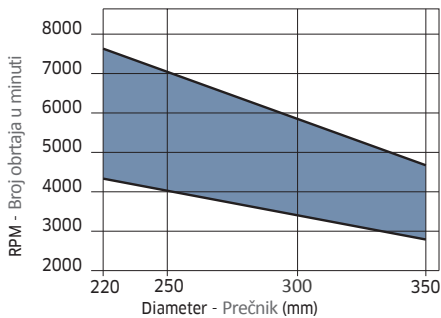

Minimum and maximum RPM based on the blade diameter.

Minimalan i maksimalan broj obrtaja u odnosu na prečnik testere.

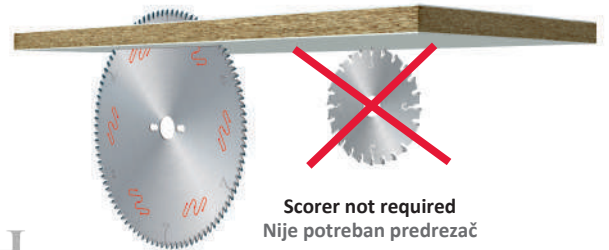

Scorer not required  
Nije potreban predrezač

GATECH  
[www.freud.rs](http://www.freud.rs)

Working with spindle over the working plane  
Rad sa osovinom iznad radnog stola

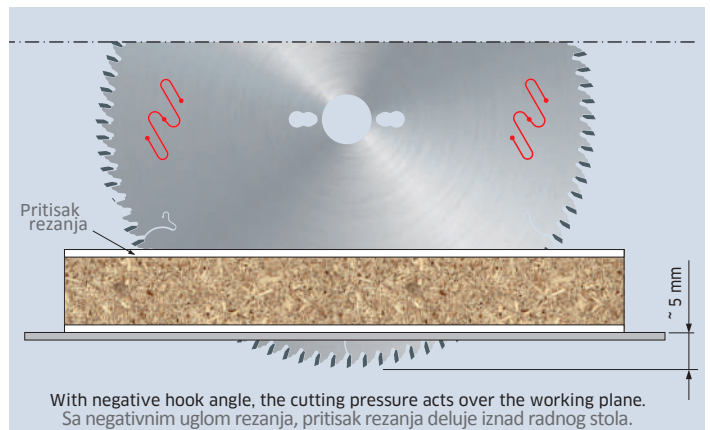

With negative hook angle, the cutting pressure acts over the working plane.  
Sa negativnim uglom rezanja, pritisak rezanja deluje iznad radnog stola.

	Ultimate Najbolja	High Odlična	Good Dobra
Wood composites Drveni kompoziti	●		
Veneered Furnir	●		
Laminates Laminati	●		

## HW - Saw blades to cut bilaminated panels

## TM - Testere za rezanje obostrano oplemenjenih pločastih materijala

To size bilaminated panels with the employment of the scoring saw blade, in detail melamine-coated panels, with good finishing and long cutting life.

**Machines:** Circular saws, horizontal panel sizing machines.

**Features:** Flat-triple chip tooth with positive cutting angle.

**Material:** Bilaminated panels.

Testere za rezanje obostrano oplemenjenih pločastih materijala, naročito sa melaminskom folijom, uz upotrebu predrezača. Odličan završni rez i dug radni vek.

**Mašine:** Stabilni cirkularni, horizontalni formatizeri.

**Oblik zuba:** Naizmenično ravni i trapezni sa pozitivnim uglom rezanja (VK).

**Materijal:** Obostrano oplemenjeni pločasti materijali (univer, MDF).

**FT01:** 2/7/42 + 2/9/46,4 + 2/10/60

**FT02:** 2/9/46,4 + 2/10/60

**Hook angle 5° for cutting heights up to 30 mm**

**Grudni ugao od 5° za materijale visine do 30mm**

D mm	B mm	b mm	d mm	Z	α	NL Pomoćni otvori	Code Šifra	SAP SAP
200	3,2	2,2	30	64	5°	2/7/42	LU3D 0100	F03FS05081
220	3,2	2,2	30	64	5°	2/7/42	LU3D 0200	F03FS05083
250	3,2	2,2	30	80	5°	FT01	LU3D 0400	F03FS05088
300	3,2	2,2	30	96	5°	FT01	LU3D 0600	F03FS05093
300	3,2	2,2	35	96	5°		LU3D 0700	F03FS05096
350	3,5	2,5	30	108	5°	FT02	LU3D 0900	F03FS05098

**Hook angle 10° for cutting heights up to 40 mm**

**Grudni ugao od 10° za materijale visine do 40mm**

D mm	B mm	b mm	d mm	Z	α	NL FT	Code Šifra	SAP SAP
250	3,2	2,2	30	60	10°	FT01	LU3D 1100	F03FS05100
300	3,2	2,2	30	72	10°	FT01	LU3D 2100	F03FS05810
300	3,2	2,2	30	84	10°	FT01	LU3D 1300	F03FS05101
300	3,2	2,2	30	96	10°	FT01	LU3D 1500	F03FS05104
350	3,5	2,5	30	72	10°	FT02	LU3D 2000	F03FS05108
350	3,5	2,5	30	108	10°	FT02	LU3D 1700	F03FS05105

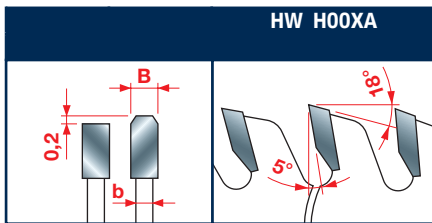
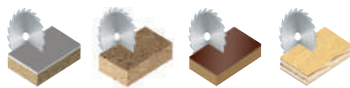
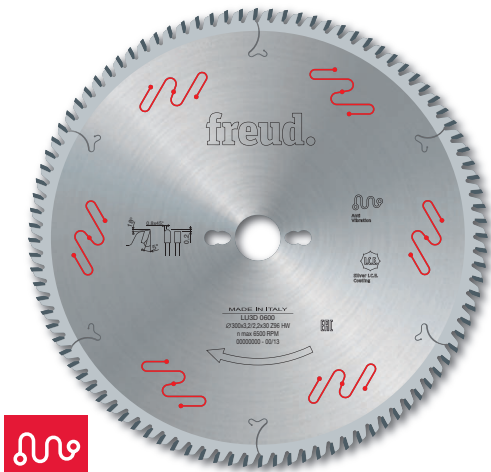

Tooth features - Karakteristike zuba

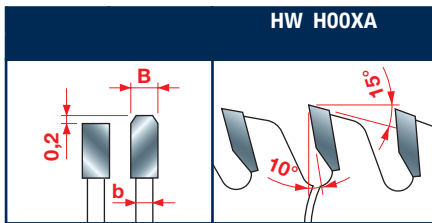

Tooth features - Karakteristike zuba

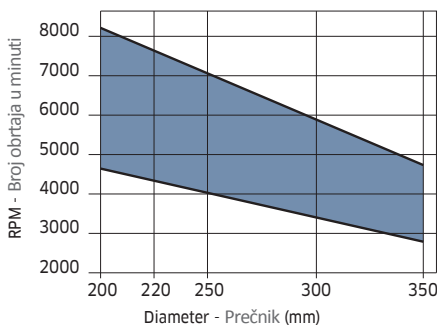

Minimum and maximum RPM based on the blade diameter.

Minimalan i maksimalan broj obrtaja u odnosu na prečnik testere.

GATECH  
www.freud.rs

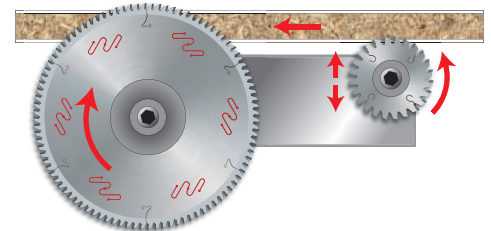

	Ultimate Najbolja	High Odlična	Good Dobra
Wood composites Drveni kompoziti	●		
Veneered Furnir	●	●	
Laminates Laminati	●		

## HW - Saw blades to cut bilaminated panels

## TM - Testere za rezanje obostrano oplemenjenih pločastih materijala

To size bilaminated panels without the employment of the scoring saw blade, up to 40 mm thick. In detail, it is suitable to work melamine-coated panels.

**Machines:** Circular saws, horizontal panel sizing machines, vertical panel sizing machines.

**Features:** Flat-triple chip tooth with negative cutting angle.

**Material:** Bilaminated panels.

Testere za rezanje obostrano oplemenjenih pločastih materijala sa melaminskom folijom, debljine do 40mm, bez upotrebe predrezača.

**Mašine:** Stabilni cirkulari, horizontalni i vertikalni formatizeri.

**Oblik zuba:** Naizmenično ravni i trapezni sa negativnim uglom rezanja.

**Materijal:** Obostrano oplemenjeni pločasti materijali (univer, MDF).

**FT01:** 2/7/42 + 2/9/46,4 + 2/10/60

**FT02:** 2/9/46,4 + 2/10/60

D	B	b	d	Z	NL	Code	SAP
mm	mm	mm	mm		Pomoćni otvori	Šifra	SAP
220	3,2	2,2	30	56	2/7/42	LU3E 0100	F03FS05109
250	3,2	2,2	30	60	FT01	LU3E 0200	F03FS05111
300	3,2	2,2	30	72	FT01	LU3E 0300	F03FS05113
350	3,5	2,5	30	84	FT02	LU3E 0400	F03FS05115

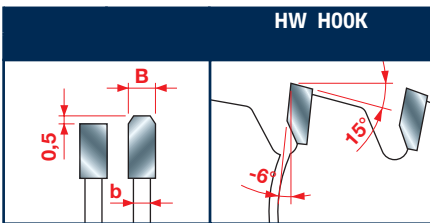
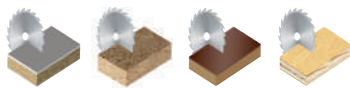

Tooth features - Karakteristike zuba



Scorer not required  
Nije potreban predrezač

GATECH  
www.freud.rs

### Working with spindle over the working plane Rad sa osovinom iznad radnog stola

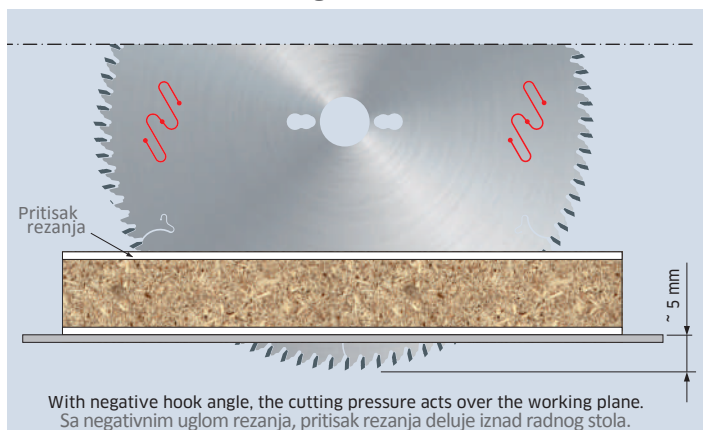

With negative hook angle, the cutting pressure acts over the working plane.  
Sa negativnim uglom rezanja, pritisak rezanja deluje iznad radnog stola.

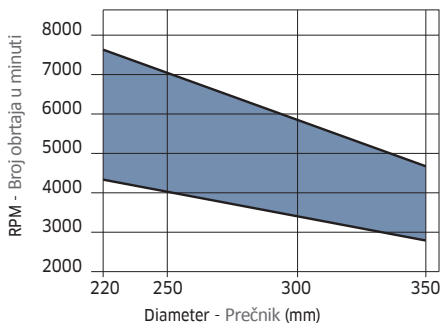

Minimum and maximum RPM based on the blade diameter.

Minimalan i maksimalan broj obrtaja u odnosu na prečnik testere.

	Ultimate Najbolja	High Odlična	Good Dobra
Wood composites Drveni kompoziti		●	
Veneered Furnir	●		
Laminates Laminati	●		



# LU3F

## HW - Saw blades to cut bilaminated panels and plastic materials

## TM - Testere za rezanje obostrano oplemenjenih pločastih materijala i plastičnih materijala

To size bilaminated panels without the employment of the scoring saw blade. In detail, it is suitable to work melamine-coated panels and plastic materials.

**Machines:** Circular saws, horizontal panel sizing machines, vertical panel sizing machines.

**Features:** Flat-triple chip tooth with negative cutting angle.

**Material:** Bilaminated panels, plastic materials.

Testere za rezanje obostrano oplemenjenih pločastih materijala sa melaminskom folijom i plastičnih materijala, bez upotrebe predrezača.

**Mašine:** Stabilni cirkulari, horizontalni i vertikalni formatizeri.

**Oblik zuba:** Naizmenično ravni i trapezni sa negativnim uglom rezanja.

**Materijal:** Obostrano oplemenjeni pločasti materijali (univer, MDF), plastični materijali.

**FT01:** 2/7/42 + 2/9/46,4 + 2/10/60

**FT02:** 2/9/46,4 + 2/10/60

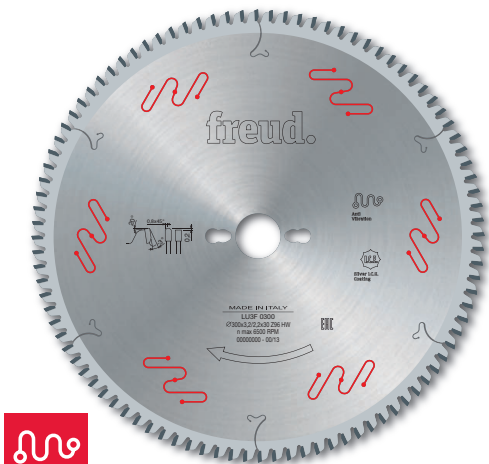

D mm	B mm	b mm	d mm	Z	NL Pomoćni otvori	Code Šifra	SAP SAP
220	3,2	2,2	30	64	2/7/42	LU3F 0100	F03FS05117
250	3,2	2,2	30	80	FT01	LU3F 0200	F03FS05119
300	3,2	2,2	30	96	FT01	LU3F 0300	F03FS05121
350	3,5	2,5	30	108	FT02	LU3F 0400	F03FS05124

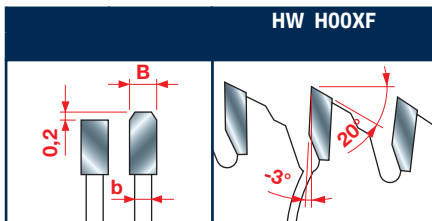

Tooth features - Karakteristike zuba

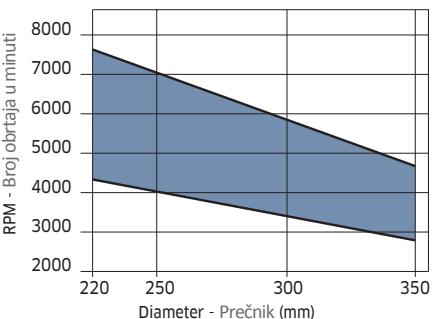

Minimum and maximum RPM based on the blade diameter.

Minimalan i maksimalan broj obrtaja u odnosu na prečnik testere.

GATECH  
www.freud.rs



### Working with spindle over the working plane Rad sa osovinom iznad radnog stola

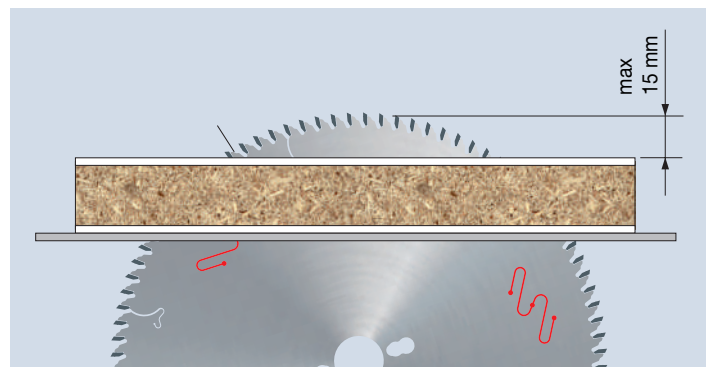

With negative hook angle, the cutting pressure acts over the working plane.  
Sa negativnim uglom rezanja, pritisak rezanja deluje iznad radnog stola.

	Ultimate Najbolja	High Odlična	Good Dobra
Wood composites Drveni kompoziti	●		
Veneered Furnir	●		
Laminates Laminati	●		

# LG1C

## HW - Saw blades to cut solid wood TM - Testere za rezanje masiva

Saw blades suitable for ripping.

**Machines:** Table saws, multiripping machines.

**Features:** ATB 10° tooth with positive cutting angle.

**Material:** Soft and hard solid wood, also with loose knots.

Testere za uzdužno rezanje masiva.

**Mašine:** Stabilni cirkulari, višelisni cirkulari.

**Oblik zuba:** ATB 10° sa pozitivnim uglom rezanja.

**Materijal:** Meko i tvrdo drvo (masiv), može i sa čvorovima.

**FT01:** 2/7/42 + 2/9/46,4 + 2/10/60

**FT02:** 2/9/46,4 + 2/10/60

D mm	B mm	b mm	d mm	Z	NL Pomoćni otvori	Code Šifra	SAP SAP
250	3,2	2,2	30	22	FT01	<b>LG1C 0100</b>	F03FS07559
300	3,2	2,2	30	26	FT01	<b>LG1C 0400</b>	F03FS07560
350	3,5	2,5	30	30	FT02	<b>LG1C 1000</b>	F03FS07561



**GATECH**  
[www.freud.rs](http://www.freud.rs)

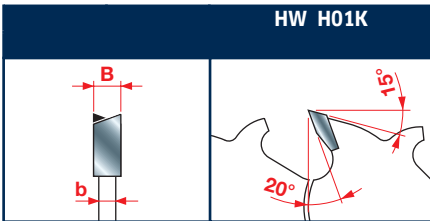

Tooth features - Karakteristike zuba

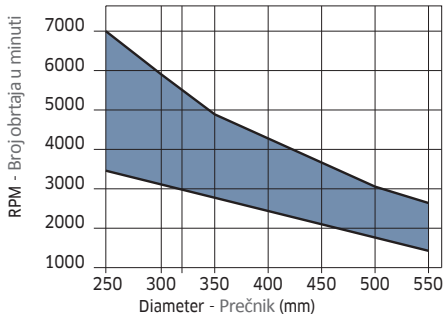

Minimum and maximum RPM based on the blade diameter.

Minimalan i maksimalan broj obrtaja u odnosu na prečnik testere.

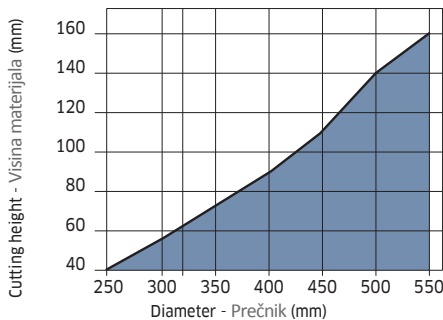

Maximum depth of cut based on the blade diameter.  
Maksimalna visina materijala koji se reže u odnosu na prečnik testere.

Solid wood  
Masiv

Ultimate Najbolja	High Odlična	Good Dobra

Ripping of softwood  
Uzdužno rezanje mekog drveta  
Ripping of hardwood  
Uzdužno rezanje tvrdog drveta

# LG2A

## HW - Saw blades to cut wooden panels and composites TM - Testere za rezanje pločastih i kompozitnih materijala

Saw blades suitable for ripping and crosscutting.

**Machines:** Circular saws, portable machines.

**Features:** ATB tooth with positive cutting angle.

**Material:** Soft and hard solid wood, unprocessed chipboard and plywood.

Testere za uzdužno i poprečno rezanje pločastih i kompozitnih materijala.

**Mašine:** Stabilni i ručni cirkulari.

**Oblik zuba:** ATB sa pozitivnim uglom rezanja.

**Materijal:** Meko i tvrdo drvo (masiv), sirova iverica i šper.

**FT01:** 2/7/42 + 2/9/46,4 + 2/10/60

**FT02:** 2/9/46,4 + 2/10/60

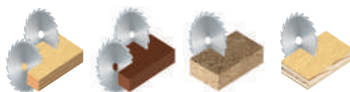

D mm	B mm	b mm	d mm	Z	NL Pomoćni otvori	Code Šifra	SAP SAP
250	3,2	2,2	30	40	FT01	LG2A 1700	F03FS07562
300	3,2	2,2	30	36	FT01	LG2A 1900	F03FS07563
300	3,2	2,2	30	48	FT01	LG2A 2100	F03FS07564
350	3,5	2,5	30	54	FT02	LG2A 2800	F03FS07565

GATECH  
www.freud.rs

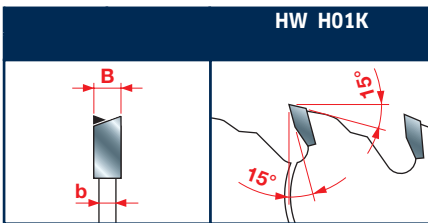

Tooth features - Karakteristike zuba

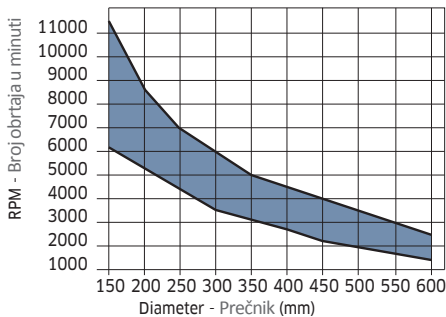

Minimum and maximum RPM based on the blade diameter.  
Minimalan i maksimalan broj obrtaja u odnosu na prečnik testere.

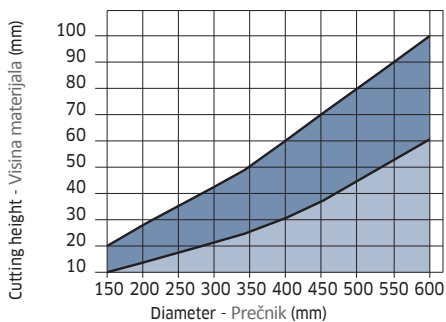

Maximum depth of cut based on the blade diameter.  
Maksimalna visina materijala koji se reže u odnosu na prečnik testere.

Solid wood / Masiv  
 Wood-base materials / Furnir

Ultimate Najbolja	High Odlična	Good Dobra
Ripping of solid wood Uzdužno rezanje masiva		
Crosscutting of solid wood Poprečno rezanje masiva		
Wood composites Drveni kompoziti		

# LG2B

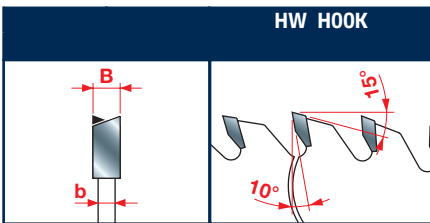
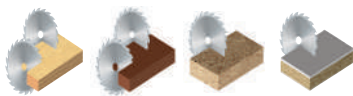

Tooth features - Karakteristike zuba

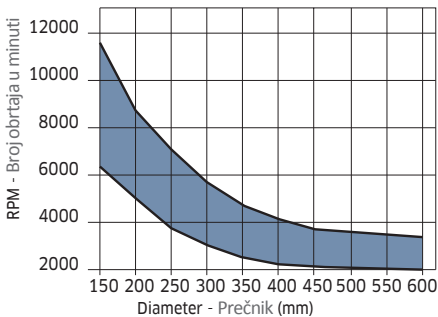

Minimum and maximum RPM based on the blade diameter.  
Minimalan i maksimalan broj obrtaja u odnosu na prečnik testere.

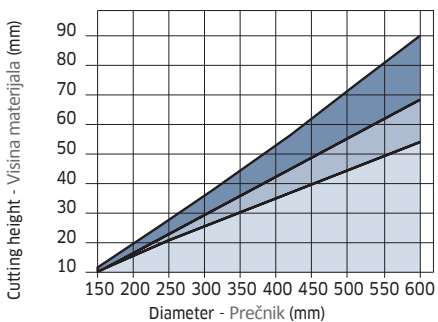

Maximum depth of cut based on the blade diameter.  
Maksimalna visina materijala koji se reže u odnosu na prečnik testere.

- Solid wood / Masiv
- Wood-base materials / Furnirani materijali
- Plywood / Šperploča

## HW - Saw blades to cut wooden panels and composites TM - Testere za rezanje pločastih i kompozitnih materijala

Saw blades suitable for ripping and crosscutting.

**Machines:** Circular saws, portable machines.

**Features:** ATB 15° tooth with positive cutting angle.

**Material:** Soft, hard and exotic solid wood, unprocessed chipboard and plywood.

Testere za uzdužno i poprečno rezanje pločastih i kompozitnih materijala.

**Mašine:** Stabilni i ručni cirkulari.

**Oblik zuba:** ATB 15° sa pozitivnim uglom rezanja.

**Materijal:** Meko, tvrdo i egzotično drvo (masiv), sirova iverica i šper.

**FT01:** 2/7/42 + 2/9/46,4 + 2/10/60

**FT02:** 2/9/46,4 + 2/10/60

D	B	b	d	Z	NL	Code	SAP
mm	mm	mm	mm		Pomoćni otvori	Šifra	SAP
250	3,2	2,2	30	60	FT01	<b>LG2B 0700</b>	F03FS07566
300	3,2	2,2	30	60	FT01	<b>LG2B 0900</b>	F03FS07567
300	3,2	2,2	30	72	FT01	<b>LG2B 1100</b>	F03FS07439
350	3,5	2,5	30	72	FT02	<b>LG2B 1400</b>	F03FS07568
350	3,5	2,5	30	84	FT02	<b>LG2B 1600</b>	F03FS07569

**GATECH**  
www.freud.rs

	Ultimate Najbolja	High Odlična	Good Dobra
Ripping of solid wood Uzdužno rezanje masiva		●	
Crosscutting of solid wood Poprečno rezanje masiva		●	
Wood composites Drveni kompoziti		●	

## HW - Saw blades to cut wooden panels and composites TM - Testere za rezanje pločastih i kompozitnih materijala

Saw blades suitable for crosscutting.

**Machines:** Circular saws, portable machines.

**Features:** ATB 15° tooth with positive cutting angle.

**Material:** Soft, hard and exotic solid wood, chipboard, thermoplastic-wood composites, MDF laminated on one side.

Testere za uzdužno i poprečno rezanje pločastih i kompozitnih materijala.

**Mašine:** Stabilni i ručni cirkularni.

**Oblik zuba:** ATB 15° sa pozitivnim uglom rezanja.

**Materijal:** Meko, tvrdo i egzotično drvo (masiv), iverica, pločasti materijali sa termoplastičnom folijom, jednostrano oplemenjeni medijapan (MDF).

**FT01:** 2/7/42 + 2/9/46,4 + 2/10/60

**FT02:** 2/9/46,4 + 2/10/60

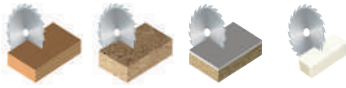

D	B	b	d	Z	NL	Code	SAP
mm	mm	mm	mm		Pomoćni otvori	Šifra	SAP
250	3,2	2,2	30	80	FT01	LG2C 1200	F03FS07570
300	3,2	2,2	30	96	FT01	LG2C 1500	F03FS07571
350	3,5	2,5	30	108	FT02	LG2C 2000	F03FS07572

GATECH  
www.freud.rs

### HW HOOK

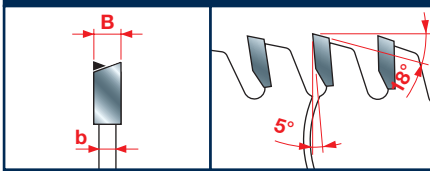

Tooth features - Karakteristike zuba

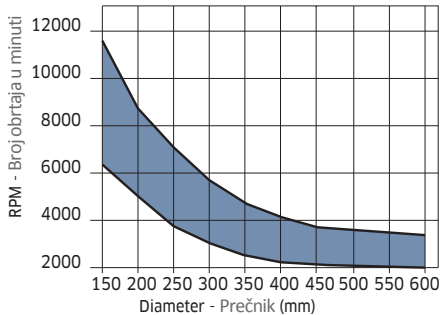

Minimum and maximum RPM based on the blade diameter.  
Minimalan i maksimalan broj obrtaja u odnosu na prečnik testere.

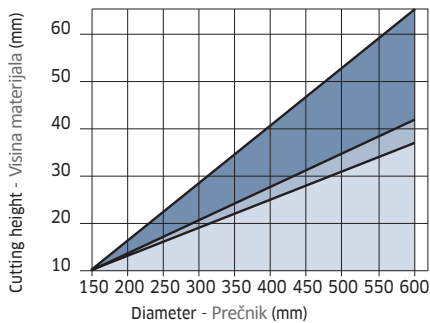

Maximum depth of cut based on the blade diameter.  
Maksimalna visina materijala koji se reže u odnosu na prečnik testere.

Solid wood / Masiv  
 Wood-base materials / Furnirani materijali  
 Plywood / Šperploča

	Ultimate Najbolja	High Odlična	Good Dobra
Ripping of solid wood Uzdužno rezanje masiva		●	
Crosscutting of solid wood Poprečno rezanje masiva		●	
Wood composites Drveni kompoziti		●	



## HW - Saw blades to cut bilaminated panels TM - Testere za rezanje pločastih materijala

To size bilaminated panels with the employment of the scoring saw blade, in detail melamine-coated panels, with good finishing and long cutting life.

**Machines:** Circular saws, horizontal panel sizing machines.

**Features:** Flat-triple chip tooth with positive cutting angle.

**Material:** Bilaminated panels.

Testere za rezanje obostrano oplemenjenih pločastih materijala, posebno onih sa melaminskom folijom, uz upotrebu predrezača. Dobar završni rez i dug radni vek.

**Mašine:** Stabilni cirkulari, horizontalni formatizeri.

**Oblik zuba:** Naizmenično ravni i trapezni sa pozitivnim uglom rezanja.

**Materijal:** Obostrano oplemenjeni pločasti materijali.

**FT01:** 2/7/42 + 2/9/46,4 + 2/10/60

**FT02:** 2/9/46,4 + 2/10/60

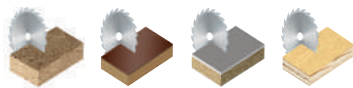

D mm	B mm	b mm	d mm	Z	$\alpha$	NL Pomoćni otvori	Code Šifra	SAP SAP
250	3,2	2,2	30	80	5°	FT01	LG3D 0400	F03FS07438
300	3,2	2,2	30	96	5°	FT01	LG3D 0600	F03FS07436
350	3,5	2,5	30	108	5°	FT02	LG3D 0900	F03FS07437

D mm	B mm	b mm	d mm	Z	$\alpha$	NL Pomoćni otvori	Code Šifra	SAP SAP
300	3,2	2,2	30	72	10°	FT01	LG3D 2100	F03FS07574
350	3,5	2,5	30	72	10°	FT02	LG3D 2000	F03FS07573

GATECH  
www.freud.rs

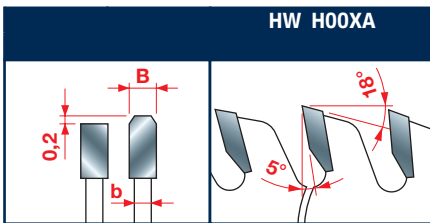

Tooth features - Karakteristike zuba

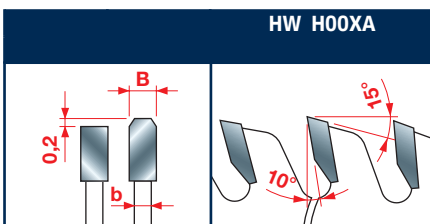

Tooth features - Karakteristike zuba

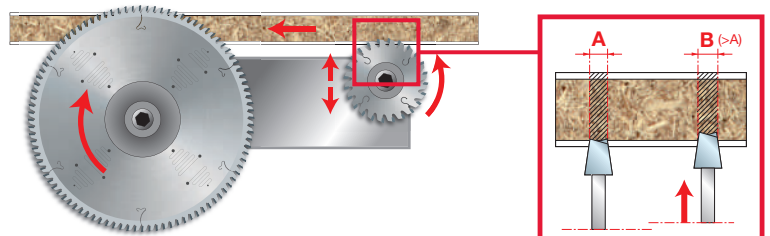

Cutting kerf  
of main saw blade  
Širina reza glavne  
testere

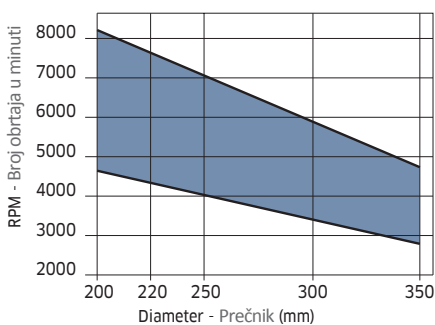

Minimum and maximum RPM based on the blade diameter.

Minimalan i maksimalan broj obrtaja u odnosu na prečnik testere.

	Ultimate Najbolja	High Odlična	Good Dobra
Wood composites Drveni kompoziti		●	
Laminates Laminati		●	

# Reference table of saw blades for panel sizing machines

## Referentna tabela testera za formatizere

Machine type Tip mašine	Tool type * Tip alata*	D mm	B-B1 mm	b mm	d mm	Z	Tooth type Tip zuba	α	β	NL Pomoćni otvori	Code Šifra	SAP SAP
<b>Anthon</b>												
LN (90)	Main saw blade	400	4,4	3,2	60	72	TCG	10°	15°	2/14/100 + 2/11/85	LSB40017	F03FS07931
	Scoring saw blade	180	4,3-5,5	3,2	20	28	CON	8°	15°		LI25M43NA3	F03FS02661
	Scoring saw blade	180	4,3-5,5	3,2	20	36	CON	8°	15°		LI25M43XA3	F03FS06372
LNA (100), LN (120)	Main saw blade	450	4,4	3,2	60	72	TCG	15°	15°	2/14/125	LSB45008X	F03FS09182
	Scoring saw blade	180	4,3-5,5	3,2	20	36	CON	8°	15°		LI25M43XA3	F03FS06372
LNB (200), LNC (210)	Main saw blade	700	6,2	4,2	80	60	TCG	18°	15°	2/17/110	LSB70001	F03FS07036
	Scoring saw blade	180	5,7-6,9	4,0	20	36	CON	8°	15°		LI25M57NA3	F03FS02727
Porta 100	Main saw blade	400	4,4	3,2	60	72	TCG	15°	15°	2/14/100+2/11/85	LSB40017	F03FS07931
	Scoring saw blade	180	4,3-5,5	3,2	20	36	CON	8°	15°		LI25M43XA3	F03FS06372
Porta 150	Main saw blade	500	4,4	3,2	60	60	TCG	15°	15°	2/11/115	LSB50009X	F03FS09189
	Scoring saw blade	180	4,3-5,5	3,2	20	36	CON	8°	15°		LI25M43XA3	F03FS06372
<b>Baldan</b>												
SH-2900	Main saw blade	250	4,2	3,0	55	60	TCG	15°	15°	GATECH www.freud.rs	LSB25002	F03FS07366
	Scoring saw blade	110	4,1 - 5,2	2,8	45	24	CON	0°	15°		LI25M41CE3	F03FS07365
SH-2945	Main saw blade	280	4,4	3,2	55	60	TCG	15°	15°	2/10/70	LSB28001	F03FS08161
	Scoring saw blade	125	4,3 - 5,5	3,2	45	24	CON	0°	15°		LI25M43FE3	F03FS02645
<b>Scm - Gabbiani</b>												
Galaxy 90	Main saw blade	300	4,4	3,0	80	60	TCG	15°	15°	4/9/100+2/14/110	LSB30004X	F03FS09157
	Main saw blade	300	4,4	3,0	80	72	TCG	15°	15°	4/9/100+2/14/110	LSB30008X	F03FS07804
	Scoring saw blade	200	4,3-5,5	3,2	80	36	CON	8°	15°	2/14/110	LI25M43PL3	F03FS02683
	Postforming scorer	300	4,7	3,2	80	72	ATB	15°	15°	2/14/110	LI27M DC3	F03FS02741
Galaxy 85	Main saw blade	350	4,4	3,2	80	72	TCG	15°	15°	4/9/100+2/9/110+2/14/110	LSB35005X	F03FS07635
	Scoring saw blade	200	4,3-5,5	3,2	80	36	CON	8°	15°	2/14/110	LI25M43PL3	F03FS02683
Galaxy 115	Main saw blade	400	4,4	3,2	80	72	TCG	15°	15°	4/9/100+2/9/110+2/14/110	LSB40012X	F03FS09173
	Scoring saw blade	200	4,3-5,5	3,2	80	36	CON	8°	15°	2/14/110	LI25M43PL3	F03FS02683
Galaxy 140, Elite	Main saw blade	450	4,4	3,2	80	72	TCG	15°	15°	2/9/130+2/14/110+4/19/120	LSB45009X	F03FS07811
	Scoring saw blade	200	4,3-5,5	3,2	80	36	CON	8°	15°	2/14/110	LI25M43PL3	F03FS02683
Galaxy3 110, 110A	Main saw blade	400	4,4	3,2	80	72	TCG	15°	15°	4/9/100+2/9/110+2/14/110	LSB40012X	F03FS09173
	Scoring saw blade	200	4,3-5,5	3,2	80	36	CON	8°	15°	2/14/110	LI25M43PL3	F03FS02683
	Postforming scorer	300	4,7	3,2	80	72	ATB	15°	15°	2/14/110	LI27M DC3	F03FS02741
Galaxy3 130, 130A	Main saw blade	430	4,4	3,2	80	72	TCG	15°	15°	2/14/110+4/19/120+2/9/130	LSB43009X	F03FS07909
	Scoring saw blade	200	4,3-5,5	3,2	80	36	CON	8°	15°	2/14/110	LI25M43PL3	F03FS02683
	Postforming scorer	300	4,7	3,2	80	72	ATB	15°	15°	2/14/110	LI27M DC3	F03FS02741
Galaxy3 145	Main saw blade	430	4,4	3,2	80	72	TCG	15°	15°	2/9/130+2/14/110+4/19/120	LSB45009X	F03FS07811
	Scoring saw blade	200	4,3-5,5	3,2	80	36	CON	8°	15°	2/14/110	LI25M43PL3	F03FS02683
<b>Giben</b>												
G 2000 Starmatic	Main saw blade	400	4,4	3,2	75	72	TCG	15°	15°	4/15/105+2/7/110	LSB40008X	F03FS07726
	Main saw blade	400	4,4	3,2	75	84	TCG	15°	15°	4/15/105+2/7/110	LSB40019X	F03FS08990
	Scoring saw blade	125	4,5-5,7	3,0	45	24	CON	0°	15°		LI25M45FE3	F03FS02699
MK, Gamma, N, ST, SE, Trend	Main saw blade	355	4,4	3,2	75	72	TCG	15°	15°	4/15/105	LSB35505X	F03FS07633
	Scoring saw blade	125	4,3-5,5	3,2	45	24	CON	0°	15°		LI25M43FE3	F03FS02645

\* Tool type - Tip alata

Main saw blade / Glavna testera, Scoring saw blade / Predrezač, Postforming scorer / Predrezač za postforming

# Reference table of saw blades for panel sizing machines

## Referentna tabela testera za formatizere

Machine type Tip mašine	Tool type * Tip alata*	D mm	B-B1 mm	b mm	d mm	Z	Tooth type Tip zuba	$\alpha$	$\beta$	NL Pomoćni otvori	Code Šifra	SAP SAP
<b>Prismatic 101</b>	Main saw blade	400	4,4	3,2	75	72	TCG	15°	15°	4/15/105+2/7/110	<b>LSB40008X</b>	F03FS07726
	Scoring saw blade	160	4,3-5,5	3,0	45	36	CON	8°	15°	3/11/70	<b>LI25M43LE3</b>	F03FS02655
<b>Prismatic 2, 3 Prismatic 2, 3</b>	Main saw blade	470	4,4	3,2	75	96	TCG	15°	15°	4/15/105	<b>LSB47004X</b>	F03FS09184
	Scoring saw blade	215	4,3-5,5	3,2	50	42	CON	8°	15°	2/7/80+3/15/80	<b>LI25M43QF3</b>	F03FS02685
	Scoring saw blade	215	4,5-5,7	3,2	50	42	CON	8°	15°	3/15/80	<b>LI25M45PF3</b>	F03FS02713
	Scoring saw blade	300	4,3-5,5	3,5	50	48	CON	12°	15°		<b>LI25M43RM3</b>	F03FS02693
	Postforming scorer	300	4,6	3,2	50	72	ATB	15°	15°	3/15/80	<b>LI27M DD3</b>	F03FS02743
<b>Prismatic 201</b>	Main saw blade	400	4,4	3,2	75	72	TCG	15°	15°	4/15/105+2/7/110	<b>LSB40008X</b>	F03FS07726
	Main saw blade	430	4,4	3,2	75	72	TCG	15°	15°	4/15/105+2/7/110	<b>LSB43008X</b>	F03FS07908
	Scoring saw blade	215	4,3-5,5	3,2	50	42	CON	8°	15°	2/7/80+3/15/80	<b>LI25M43QF3</b>	F03FS02685
	Scoring saw blade	300	4,3-5,5	3,5	50	48	CON	12°	15°		<b>LI25M43RM3</b>	F03FS02693
	Postforming scorer	300	4,6	3,2	50	72	ATB	15°	15°	3/15/80	<b>LI27M DD3</b>	F03FS02743
<b>Smart SP105, Icon 105</b>	Main saw blade	380	4,4	3,2	50	72	ATB	15°	15°	4/13/80	<b>LSB38008X</b>	F03FS09165
	Scoring saw blade	250	4,3-5,5	3,2	50	48	CON	6°	15°		<b>LI25M430F3</b>	F03FS02669
	Postforming scorer	380	4,4	3,2	50	60	ATB	10°	15°	4/13/80	<b>LSB38007</b>	F03FS04000
<b>Haisung Woodworking Machinery</b>												
<b>HSWWMC- 2600III/3200III</b>	Main saw blade	400	4,4	3,2	75	72	TCG	15°	15°	4/15/105+2/7/110	<b>LSB40008X</b>	F03FS07726
	Scoring saw blade	152	4,3 - 5,5	3,2	45	36	CON	8°	15°		<b>LI25M43KE3</b>	F03FS02651
<b>Hansol Machine</b>												
<b>NCNC- 2600H10/2600H13/3660H13</b>	Main saw blade	400	4,4	3,2	75	72	TCG	15°	15°	4/15/105+2/7/110	<b>LSB40008X</b>	F03FS07726
	Scoring saw blade	145	4,3 - 5,5	3,2	45	30	CON	8°	15°		<b>LI25M43WE3</b>	F03FS08015
<b>NCNC-2600</b>	Main saw blade	350	4,4	3,2	75	72	TCG	15°	15°		<b>LSB35008X</b>	F03FS07634
	Scoring saw blade	145	4,3 - 5,5	3,2	45	30	CON	8°	15°		<b>LI25M43WE3</b>	F03FS08015
<b>Holz Her</b>												
<b>Cut 110</b>	Main saw blade	400	4,4	3,2	30	72	TCG	15°	15°	2/10/60+2/13/94	<b>LSB40007X</b>	F03FS07725
	Scoring saw blade	250	4,3-5,5	3,2	30	48	CON	6°	15°	2/10/60	<b>LI25M430C3</b>	F03FS02668
	Postforming scorer	250	4,6	3,2	30	48	ATB	8°	15°		<b>LI27M BA3</b>	F03FS02734
<b>Cut 85, 82</b>	Main saw blade	350	4,4	3,2	30	72	TCG	15°	15°	2/10/60	<b>LSB35003X</b>	F03FS07630
	Scoring saw blade	180	4,3-5,5	3,2	30	28	CON	8°	15°		<b>LI25M43NC3</b>	F03FS02663
	Scoring saw blade	180	4,3-5,5	3,2	30	36	CON	8°	15°		<b>LI25M43XN3</b>	F03FS06373
	Postforming scorer	250	4,6	3,0	30	48	ATB	10°	15°		<b>LI27M BA3</b>	F03FS02734
<b>Holzma</b>												
<b>22</b>	Main saw blade	500	4,8	3,5	60	72	TCG	15°	15°	2/11/115	<b>LSB50011X</b>	F03FS09191
	Scoring saw blade	200	4,7-5,9	3,5	45	36	CON	8°	15°		<b>LI25M47PE3</b>	F03FS02719
	Postforming scorer	340	5,0	3,5	45	108	ATB	15°	15°	3/14/65	<b>LI27M EB3</b>	F03FS02747
<b>HPP180</b>	Main saw blade	380	4,4	3,2	60	72	TCG	15°	15°	2/14/100	<b>LSB38002X</b>	F03FS07631
	Scoring saw blade	180	4,3-5,5	3,2	45	36	CON	8°	15°		<b>LI25M43NE3</b>	F03FS02664
	Scoring saw blade	200	4,3-5,5	3,2	45	36	CON	8°	15°		<b>LI25M43PE3</b>	F03FS02676
<b>HPP350</b>	Main saw blade	350	4,4	3,2	60	72	TCG	15°	15°	2/14/100	<b>LSB35008X</b>	F03FS07634
	Scoring saw blade	180	4,3-5,5	3,2	45	36	CON	8°	15°		<b>LI25M43NE3</b>	F03FS02664

\* Tool type - Tip alata

Main saw blade / Glavna testera, Scoring saw blade / Predrezač, Postforming scorer / Predrezač za postforming

# Reference table of saw blades for panel sizing machines

## Referentna tabela testera za formatizere

Machine type Tip mašine	Tool type * Tip alata*	D mm	B-B1 mm	b mm	d mm	Z	Tooth type Tip zuba	$\alpha$	$\beta$	NL Pomoćni otvori	Code Šifra	SAP SAP
<b>HPP380, 82</b>	Main saw blade	380	4,4	3,2	60	72	TCG	15°	15°	2/14/100	<b>LSB38002X</b>	F03FS07631
	Main saw blade	380	4,8	3,5	60	72	TCG	15°	15°	2/14/100	<b>LSB38004X</b>	F03FS07632
	Main saw blade	380	4,8	3,5	60	84	TCG	15°	15°	2/14/100	<b>LSB38005X</b>	F03FS07807
	Scoring saw blade	180	4,3-5,5	3,2	45	36	CON	8°	15°		<b>LI25M43NE3</b>	F03FS02664
	Scoring saw blade	180	4,7-5,9	3,5	45	36	CON	8°	15°		<b>LI25M47NE3</b>	F03FS02715
	Postforming scorer	280	5,0	3,5	45	84	ATB	15°	15°		<b>LI27M CA3</b>	F03FS02736
<b>HPL410</b>	Main saw blade	420	4,8	3,5	60	60	TCG	15°	15°	2/14/125	<b>LSB42001</b>	F03FS04045
	Main saw blade	420	4,8	3,5	60	84	TCG	15°	15°	2/14/100+2/14/125	<b>LSB42002X</b>	F03FS09176
	Scoring saw blade	180	4,7-5,9	3,5	45	36	CON	8°	15°		<b>LI25M47NE3</b>	F03FS02715
	Postforming scorer	340	5,0	3,5	45	108	ATB	15°	15°	3/14/65	<b>LI27M EB3</b>	F03FS02747
<b>HPL550</b>	Main saw blade	520	4,8	3,5	60	72	TCG	15°	15°	2/11/115+2/19/120	<b>LSB52003X</b>	F03FS09192
	Scoring saw blade	200	4,7-5,9	3,5	45	36	CON	8°	15°		<b>LI25M47PE3</b>	F03FS02719
	Postforming scorer	340	5,0	3,5	45	108	ATB	15°	15°	3/14/65	<b>LI27M EB3</b>	F03FS02747
<b>HPL570</b>	Main saw blade	570	4,8	3,5	60	60	TCG	15°	15°	2/11/115+2/19/120	<b>LSB57001X</b>	F03FS09199
	Scoring saw blade	200	4,7-5,9	3,5	45	36	CON	8°	15°		<b>LI25M47PE3</b>	F03FS02719
	Postforming scorer	340	5,0	3,5	45	108	ATB	15°	15°	3/14/65	<b>LI27M EB3</b>	F03FS02747
<b>HPP230, 250 (before / pre 06/2014)</b>	Main saw blade	300	4,4	3,2	60	72	TCG	15°	15°	2/14/100	<b>LSB30012X</b>	F03FS09207
	Main saw blade	350	4,4	3,2	60	72	ATB	15°	15°	2/14/100	<b>LSB35004X</b>	F03FS07636
	Scoring saw blade	200	4,3-5,5	3,2	45	36	CON	8°	15°		<b>LI25M43PE3</b>	F03FS02676
	Scoring saw blade	180	4,3-5,5	3,2	45	36	CON	8°	15°		<b>LI25M43NE3</b>	F03FS02664
<b>HPP130</b>	Main saw blade	300	4,4	3,2	60	60	TCG	15°	15°	2/14/100	<b>LSB30012X</b>	F03FS09207
	Scoring saw blade	150	4,3-5,6	3,2	45	36	CON	8°	15°		<b>LI25M43KE3</b>	F03FS02651
	Scoring saw blade	180	4,3-5,5	3,2	45	36	CON	8°	15°		<b>LI25M43NE3</b>	F03FS02664
<b>HPP42, 33</b>	Main saw blade	600	5,8	4,0	60	60	TCG	15°	15°	2/11/115+2/19/120	<b>LSB60001X</b>	F03FS09200
	Main saw blade	600	5,8	4,0	60	72	TCG	15°	15°	2/11/115+2/19/120	<b>LSB60002X</b>	F03FS09201
	Scoring saw blade	200	5,7-6,9	4,0	45	36	CON	8°	15°		<b>LI25M57PE3</b>	F03FS02728
<b>HPP430, 510, 11</b>	Main saw blade	450	4,8	3,5	60	72	TCG	15°	15°	2/17/100+2/14/125	<b>LSB45017X</b>	F03FS07391
	Scoring saw blade	180	4,7-5,9	3,5	45	36	CON	8°	15°		<b>LI25M47NE3</b>	F03FS02715
	Postforming scorer	340	5,0	3,5	45	108	ATB	15°	15°	3/14/65	<b>LI27M EB3</b>	F03FS02747
<b>HPP61, 66</b>	Main saw blade	670	5,8	4,2	60	60	TCG	18°	13°	2/11/148+2/19/120	<b>LSB67001</b>	F03FS04214
	Main saw blade	730	6,2	4,2	60	60	TCG	18°	15°	2/11/148+2/19/120	<b>LSB73001</b>	F03FS04220
	Scoring saw blade	200	6,1-7,3	4,2	45	36	CON	8°	15°		<b>LI25M61PE3</b>	F03FS02731
<b>Homag</b>												
<b>CH 04</b>	Main saw blade	355	4,4	3,2	75	72	TCG	15°	15°	3/7/100	<b>LSB35507X</b>	F03FS07710
	Scoring saw blade	180	4,3-5,5	3,2	45	36	CON	8°	15°		<b>LI25M43NE3</b>	F03FS02664
	Postforming scorer	300	4,5	3,0	75	72	ATB	10°	15°		<b>LI27M DE3</b>	F03FS02744
<b>CH 08/12</b>	Main saw blade	400	4,4	3,2	75	72	TCG	15°	15°	4/15/105+2/7/110	<b>LSB40008X</b>	F03FS07726
	Scoring saw blade	150	4,3-5,6	3,2	45	36	CON	8°	15°		<b>LI25M43KE3</b>	F03FS02651
<b>CH 3</b>	Main saw blade	300	4,4	3,0	75	60	TCG	10°	15°		<b>LSB30003</b>	F03FS03916
	Scoring saw blade	125	4,3-5,5	3,2	45	24	CON	0°	15°		<b>LI25M43FE3</b>	F03FS02645
<b>CT 04/40</b>	Main saw blade	300	4,4	3,0	75	60	TCG	10°	15°		<b>LSB30003</b>	F03FS03916
	Scoring saw blade	150	4,3-5,6	3,2	45	36	CON	8°	15°		<b>LI25M43KE3</b>	F03FS02651

\* Tool type - Tip alata

Main saw blade / Glavna testera, Scoring saw blade / Predrezač, Postforming scorer / Predrezač za postforming

# Reference table of saw blades for panel sizing machines

## Referentna tabela testera za formatizere

Machine type Tip mašine	Tool type * Tip alata*	D mm	B-B1 mm	b mm	d mm	Z	Tooth type Tip zuba	$\alpha$	$\beta$	NL Pomoćni otvori	Code Šifra	SAP SAP
CV's	Main saw blade	300	4,4	3,0	75	60	TCG	10°	15°		LSB30003	F03FS03916
	Scoring saw blade	125	4,3-5,5	3,2	45	24	CON	0°	15°		LI25M43FE3	F03FS02645
<b>Hyundai Sangi</b>												
CNC-740SD/CNC-740LSD	Main saw blade	400	4,4	3,2	75	72	TCG	15°	15°	4/15/105+2/7/110	LSB40008X	F03FS07726
	Scoring saw blade	200	4,3 - 5,5	3,2	45	36	CON	8°	15°		LI25M43PE3	F03FS02676
	Scoring saw blade	200	4,3 - 5,5	3,2	75	36	CON	8°	15°		LI25M43PT3	F03FS07755
CNC-760SD/CNC-760LSD	Main saw blade	470	4,4	3,2	75	72	TCG	15°	15°	4/15/105	LSB47003X	F03FS09813
	Scoring saw blade	200	4,3 - 5,5	3,2	45	36	CON	8°	15°		LI25M43PE3	F03FS02676
	Scoring saw blade	200	4,3 - 5,5	3,2	75	36	CON	8°	15°		LI25M43PT3	F03FS07755
<b>KDT</b>												
KS-226, 232	Main saw blade	355	4,4	3,2	75	72	TCG	15°	15°	4/15/105	LSB35505X	F03FS07633
	Main saw blade	400	4,4	3,2	75	72	TCG	15°	15°	4/15/105+2/7/110	LSB40008X	F03FS07726
	Main saw blade	400	4,4	3,2	75	84	TCG	15°	15°	4/15/105+2/7/110	LSB40019X	F03FS08990
	Scoring saw blade	180	4,3-5,5	3,2	30	36	CON	8°	15°		LI25M43XN3	F03FS06373
KS-829P, 829CP	Main saw blade	400	4,4	3,2	75	72	TCG	15°	15°	4/15/105+2/7/110	LSB40008X	F03FS07726
	Main saw blade	400	4,4	3,2	75	84	TCG	15°	15°	4/15/105+2/7/110	LSB40019X	F03FS08990
	Scoring saw blade	200	4,3-5,5	3,2	50	36	CON	8°	15°	2/7/80	LI25M43PF3	F03FS02679
KS-823P, 832CP	Main saw blade	400	4,4	3,2	75	72	TCG	15°	15°	4/15/105+2/7/110	LSB40008X	F03FS07726
	Main saw blade	400	4,4	3,2	75	84	TCG	15°	15°	4/15/105+2/7/110	LSB40019X	F03FS08990
	Scoring saw blade	200	4,3-5,5	3,2	50	36	CON	8°	15°	2/7/80	LI25M43PF3	F03FS02679
KS-838CP	Main saw blade	400	4,4	3,2	75	72	TCG	15°	15°	4/15/105+2/7/110	LSB40008X	F03FS07726
	Main saw blade	400	4,4	3,2	75	84	TCG	15°	15°	4/15/105+2/7/110	LSB40019X	F03FS08990
	Scoring saw blade	200	4,3-5,5	3,2	50	36	CON	8°	15°	2/7/80	LI25M43PF3	F03FS02679
<b>Nanxing</b>												
NZH3318, NPD380	Main saw blade	450	4,8	3,5	60	72	TCG	15°	15°	2/17/100+2/14/125	LSB45017X	F03FS07391
	Scoring saw blade	180	4,7-5,9	3,5	45	36	CON	8°	15°		LI25M47NE3	F03FS02715
NPL330HG, NP330H, NP330HG	Main saw blade	450	4,8	3,5	60	72	TCG	15°	15°	2/17/100+2/14/125	LSB45017X	F03FS07391
	Scoring saw blade	180	4,7-5,9	3,5	45	36	CON	8°	15°		LI25M47NE3	F03FS02715
NPC330	Main saw blade	380	4,4	3,2	60	72	TCG	15°	15°	2/14/100	LSB38002X	F03FS07631
	Main saw blade	350	4,4	3,2	60	72	TCG	15°	15°	2/14/100	LSB35004X	F03FS07636
	Scoring saw blade	200	4,3-5,5	3,2	45	36	CON	8°	15°		LI25M43PE3	F03FS02676
NP380FG, NP330FG, NP330F	Main saw blade	400	4,4	3,2	60	72	TCG	15°	15°	2/14/100	LSB40017X	F03FS09272
	Main saw blade	400	4,4	3,2	60	84	TCG	15°	15°	2/14/100	LSB40021X	F03FS09255
	Scoring saw blade	180	4,3-5,5	3,2	30	36	CON	8°	15°	GATECH www.freud.rs	LI25M43XN3	F03FS06373
NP280FG, NP280F	Scoring saw blade	180	4,3-5,5	3,2	30	28	CON	8°	15°		LI25M43NC3	F03FS02663
	Main saw blade	400	4,4	3,2	60	72	TCG	15°	15°	2/14/100	LSB40017X	F03FS09272
	Main saw blade	400	4,4	3,2	60	84	TCG	15°	15°	2/14/100	LSB40021X	F03FS09255
	Main saw blade	350	4,4	3,2	60	72	TCG	15°	15°	2/14/100	LSB35004X	F03FS07636
	Scoring saw blade	180	4,3-5,5	3,2	30	36	CON	8°	15°		LI25M43XN3	F03FS06373
	Scoring saw blade	180	4,3-5,5	3,2	30	28	CON	8°	15°		LI25M43NC3	F03FS02663

\* Tool type - Tip alata

Main saw blade / Glavna testera, Scoring saw blade / Predrezač, Postforming scorer / Predrezač za postforming



# Reference table of saw blades for panel sizing machines

## Referentna tabela testera za formatizere

Machine type Tip mašine	Tool type * Tip alata*	D mm	B-B1 mm	b mm	d mm	Z	Tooth type Tip zuba	$\alpha$	$\beta$	NL Pomoćni otvori	Code Šifra	SAP SAP
<b>Panhans</b>												
<b>693/SH 110</b>	Main saw blade	400	4,4	3,2	30	72	TCG	15°	15°	2/10/60+2/13/94	<b>LSB40007X</b>	F03FS07725
	Scoring saw blade	180	4,3-5,5	3,2	30	28	CON	8°	15°		<b>LI25M43NC3</b>	F03FS02663
<b>Euro 10 SF</b>	Main saw blade	300	4,4	3,0	30	60	TCG	15°	15°	2/10/60	<b>LSB30001X</b>	F03FS07802
	Scoring saw blade	250	4,3-5,5	3,2	30	48	CON	8°	15°	2/10/60	<b>LI25M430C3</b>	F03FS02668
	Postforming scorer	250	4,6	3,0	30	48	ATB	15°	15°		<b>LI27M BA3</b>	F03FS02734
<b>Euro 12 SF</b>	Main saw blade	350	4,4	3,2	30	72	TCG	15°	15°	2/10/60	<b>LSB35003X</b>	F03FS07630
	Scoring saw blade	280	4,3-5,5	3,2	30	48	CON	6°	15°	2/10/60	<b>LI25M43VC3</b>	F03FS07419
<b>Euro 12, 30</b>	Main saw blade	350	4,4	3,2	30	72	TCG	15°	15°	2/10/60	<b>LSB35003X</b>	F03FS07630
	Scoring saw blade	180	4,3-5,5	3,2	30	28	CON	8°	15°		<b>LI25M43NC3</b>	F03FS02663
<b>Euro 32</b>	Main saw blade	370	4,4	3,2	30	72	TCG	10°	15°	2/10/60	<b>LSB37001</b>	F03FS03984
	Scoring saw blade	180	4,3-5,5	3,2	30	28	CON	8°	15°		<b>LI25M43NC3</b>	F03FS02663
<b>Euro 5 (SF, Compact, Ecopan)</b>	Main saw blade	300	4,4	3,0	30	60	TCG	15°	15°	2/10/60	<b>LSB30001X</b>	F03FS07802
	Scoring saw blade	125	4,3-5,5	3,0	20	24	CON	0°	15°		<b>LI25M43FA3</b>	F03FS02643
<b>Euro10, 693/SH 70</b>	Main saw blade	300	4,4	3,0	30	60	TCG	15°	15°	2/10/60	<b>LSB30001X</b>	F03FS07802
	Scoring saw blade	125	4,3-5,5	3,2	20	24	CON	0°	15°		<b>LI25M43FA3</b>	F03FS02643
	Scoring saw blade	180	4,3-5,5	3,2	30	28	CON	8°	15°		<b>LI25M43NC3</b>	F03FS02663
<b>Eurostar 2 XL, Polystar</b>	Main saw blade	370	4,4	3,2	30	72	TCG	15°	15°	2/10/60	<b>LSC37001</b>	F03FS06312
	Scoring saw blade	180	4,3-5,5	3,2	30	28	CON	8°	15°		<b>LI25M43NC3</b>	F03FS02663
	Scoring saw blade	280	4,3-5,5	3,2	30	48	CON	6°	15°	2/10/60	<b>LI25M43VC3</b>	F03FS07419
<b>Eurostar 2 XXL</b>	Main saw blade	400	4,4	3,2	30	72	TCG	15°	15°	2/10/60+2/13/94	<b>LSB40007X</b>	F03FS07725
	Scoring saw blade	180	4,3-5,5	3,2	30	28	CON	8°	15°		<b>LI25M43NC3</b>	F03FS02663
	Scoring saw blade	280	4,3-5,5	3,2	30	48	CON	6°	15°	2/10/60	<b>LI25M43VC3</b>	F03FS07419
<b>Polypan 47</b>	Main saw blade	350	4,4	3,2	30	72	TCG	15°	15°	2/10/60	<b>LSB35003X</b>	F03FS07630
	Scoring saw blade	180	4,3-5,5	3,2	30	28	CON	8°	15°	GATECH www.freud.rs	<b>LI25M43NC3</b>	F03FS02663
	Postforming scorer	300	4,6	3,0	30	72	ATB	15°	15°		<b>LI27M DF3</b>	F03FS02745
<b>S 45</b>	Main saw blade	300	4,4	3,0	30	60	TCG	15°	15°	2/10/60	<b>LSB30001X</b>	F03FS07802
	Main saw blade	350	4,4	3,2	30	72	TCG	15°	15°	2/10/60	<b>LSB35003X</b>	F03FS07630
	Scoring saw blade	180	4,3-5,5	3,2	30	28	CON	8°	15°		<b>LI25M43NC3</b>	F03FS02663
<b>Scheer</b>												
<b>PA 6000, 5500</b>	Main saw blade	350	4,4	3,2	30	72	TCG	15°	15°	2/10/60	<b>LSB35003X</b>	F03FS07630
	Scoring saw blade	200	4,3-5,5	3,2	30	36	CON	8°	15°	2/9/60 + 2/10/60	<b>LI25M43PC3</b>	F03FS02674
<b>ATH</b>	Main saw blade	620	6,2	4,2	40	60	TCG	18°	13°	2/13/114+2/13/140	<b>LSB62001</b>	F03FS04212
	Main saw blade	620	6,2	4,2	40	72	TCG	15°	15°	2/13/114+2/13/140	<b>LSB62002</b>	F03FS04213
	Scoring saw blade	200	6,1-7,3	4,2	20	36	CON	8°	15°	2/11/66	<b>LI25M61PA3</b>	F03FS02730
<b>Schelling</b>												
<b>ASH (FSM)</b>	Main saw blade	720	6,4	4,4	40	60	TCG	18°	13°	2/14/114+2/14/140	<b>LSB72001X</b>	F03FS09204
	Scoring saw blade	220	6,3-7,5	3,2	20	36	CON	8°	15°	2/11/66	<b>LI25M63UA3</b>	F03FS02732
<b>FK10, FM10</b>	Main saw blade	680	6,2	4,2	40	60	TCG	18°	13°	2/13/140+ 2/17/140+2/13/114	<b>LSB68001X</b>	F03FS09203
	Scoring saw blade	200	6,1-7,3	4,2	20	36	CON	8°	15°	2/11/66	<b>LI25M61PA3</b>	F03FS02730
<b>FH4 (till / fino al 06/2015)</b>	Main saw blade	350	4,4	3,2	30	72	TCG	15°	15°	2/10/60	<b>LSB35003X</b>	F03FS07630
	Scoring saw blade	300	4,3-5,5	3,2	30	36	CON	8°	15°	2/11/75+2/13/94	<b>LI25M43RC3</b>	F03FS07577

\* Tool type - Tip alata

Main saw blade / Glavna testera, Scoring saw blade / Predrezač, Postforming scorer / Predrezač za postforming

# Reference table of saw blades for panel sizing machines

## Referentna tabela testera za formatizere

Machine type Tip mašine	Tool type * Tip alata*	D mm	B-B1 mm	b mm	d mm	Z	Tooth type Tip zuba	$\alpha$	$\beta$	NL Pomoćni otvori	Code Šifra	SAP SAP
<b>Schelling FH4</b> (from / od 07/2015 till / do 07/2017)	Main saw blade	360	4,4	3,2	30	72	TCG	15°	15°	2/13/94	<b>LSB36003X</b>	F03FS09341
	Scoring saw blade	200	4,3-5,5	3,2	20	36	CON	8°	15°	2/11/66 +2/10/60+2/9/62	<b>LI25M43PA3</b>	F03FS02670
<b>FH4 (starting from / počevši od 07/2017)</b>	Main saw blade	360	4,4	3,2	30	72	TCG	15°	15°	2/13/94	<b>LSB36003X</b>	F03FS09341
	Scoring saw blade	300	4,3-5,5	3,2	30	36	CON	8°	15°	2/11/75+2/13/94	<b>LI25M43RC3</b>	F03FS07577
<b>FH5</b>	Main saw blade	400	4,4	3,2	30	72	TCG	15°	15°	2/10/60+2/13/94	<b>LSB40007X</b>	F03FS07725
	Scoring saw blade	200	4,3-5,5	3,2	20	36	CON	8°	15°	2/11/66 +2/10/60+2/9/62	<b>LI25M43PA3</b>	F03FS02670
<b>FH5 (starting from / počevši od 07/2015)</b>	Main saw blade	400	4,4	3,2	30	72	TCG	15°	15°	2/10/60+2/13/94	<b>LSB40007X</b>	F03FS07725
	Scoring saw blade	300	4,3-5,5	3,2	30	36	CON	8°	15°	2/11/75+2/13/94	<b>LI25M43RC3</b>	F03FS07577
<b>FH6, AH6, CH6</b> (till 06/2015)	Main saw blade	460	4,4	3,2	30	72	TCG	15°	15°	2/13/94	<b>LSB46001X</b>	F03FS08922
	Scoring saw blade	200	4,3-5,5	3,2	20	36	CON	8°	15°	2/11/66 +2/10/60+2/9/62	<b>LI25M43PA3</b>	F03FS02670
<b>FH6, AH6, CH6</b> (starting from / počevši od 07/2015)	Main saw blade	480	4,8	3,5	30	72	TCG	15°	15°	2/10/60+2/13/94	<b>LSB48004X</b>	F03FS09187
	Scoring saw blade	220	4,7-5,9	3,5	20	36	CON	8°	15°	2/09/62	<b>LI25M47UA3</b>	F03FS09266
	Scoring saw blade	200	4,7-5,9	3,5	20	36	CON	8°	15°	2/11/66	<b>LI25M47PA3</b>	F03FS02716
<b>FH8, AH8, CH8</b>	Main saw blade	520	4,8	3,5	30	72	TCG	15°	15°	2/13/94	<b>LSB52007</b>	F03FS07878
	Scoring saw blade	220	4,7-5,9	3,5	20	36	CON	8°	15°	2/9/62	<b>LI25M47UA3</b>	F03FS09266
	Scoring saw blade	200	4,7-5,9	3,5	20	36	CON	8°	15°	2/11/66	<b>LI25M47PA3</b>	F03FS02716
<b>FK4 (till / do 06/2015)</b>	Main saw blade	350	4,4	3,2	30	72	TCG	15°	15°	2/10/60	<b>LSB35003X</b>	F03FS07630
	Scoring saw blade	300	4,3-5,5	3,2	30	48	CON	6°	15°	2/11/75+2/13/94	<b>LI25M43RC3</b>	F03FS07577
<b>FK4 (starting from / počevši od 07/2015)</b>	Main saw blade	400	4,4	3,2	30	72	TCG	15°	15°	2/10/60+2/13/94	<b>LSB40007X</b>	F03FS07725
	Scoring saw blade	200	4,3-5,5	3,2	20	36	CON	8°	15°	2/11/66 +2/10/60+2/9/62	<b>LI25M43PA3</b>	F03FS02670
<b>FK4 (starting from / počevši od 07/2017)</b>	Main saw blade	400	4,4	3,2	30	72	TCG	15°	15°	2/10/60+2/13/94	<b>LSB40007X</b>	F03FS07725
	Scoring saw blade	300	4,3-5,5	3,2	30	48	CON	6°	15°	2/11/75+2/13/94	<b>LI25M43RC3</b>	F03FS07577
<b>FK6, FP6, FM6</b>	Main saw blade	460	4,4	3,2	30	72	TCG	15°	15°	2/13/94	<b>LSB46001X</b>	F03FS08922
	Scoring saw blade	200	4,3-5,5	3,2	20	36	CON	8°	15°	2/11/66 +2/10/60+2/9/62	<b>LI25M43PA3</b>	F03FS02670
<b>FK8, FM8</b>	Main saw blade	520	4,8	3,5	30	72	TCG	15°	15°	2/13/94	<b>LSB52007</b>	F03FS07878
	Scoring saw blade	200	4,7-5,9	3,5	20	36	CON	8°	15°	2/11/66	<b>LI25M47PA3</b>	F03FS02716
<b>SCM</b>												
<b>Prima 50</b>	Main saw blade	300	4,4	3,0	80	60	TCG	15°	15°	4/9/100+2/14/110	<b>LSB30004X</b>	F03FS09157
	Main saw blade	300	4,4	3,2	80	72	TCG	15°	15°	4/9/100+2/14/110	<b>LSB30008X</b>	F03FS07804
	Scoring saw blade	160	4,3-5,5	3,2	55	36	CON	8°	15°	3/6/84+3/7/66	<b>LI25M43LG3</b>	F03FS02657
<b>Prima 67</b>	Main saw blade	320	4,4	3,2	80	60	TCG	10°	15°	4/9/100+2/9/110+2/14/110	<b>LSB32006</b>	F03FS07907
	Scoring saw blade	160	4,3-5,5	3,2	55	36	CON	8°	15°	3/6/84+3/7/66	<b>LI25M43LG3</b>	F03FS02657
	Postforming scorer	280	4,7	3,2	80	72	ATB	15°	15°	2/14/110	<b>LI27M47VL3</b>	F03FS08014
<b>Impact 105 C/D, Plus 105 C/D/P</b>	Main saw blade	380	4,4	3,2	80	72	TCG	15°	15°	4/9/100+2/9/110+2/14/110	<b>LSB38010X</b>	F03FS07808
	Scoring saw blade	160	4,3-5,5	3,2	55	36	CON	8°	15°	3/6/84+3/7/66	<b>LI25M43LG3</b>	F03FS02657
<b>Impact 85 K</b>	Main saw blade	350	4,4	3,2	80	72	TCG	15°	15°	4/9/100+2/9/110+2/14/110	<b>LSB35005X</b>	F03FS07635
	Scoring saw blade	160	4,3-5,5	3,2	55	36	CON	8°	15°	3/6/84+3/7/66	<b>LI25M43LG3</b>	F03FS02657
<b>Impact 90</b>	Main saw blade	380	4,4	3,2	80	48	TCG	15°	15°	4/9/100+2/9/110+2/14/110	<b>LSB38009X</b>	F03FS09164
	Scoring saw blade	160	4,3-5,5	3,2	55	36	CON	8°	15°	3/6/84+3/7/66	<b>LI25M43LG3</b>	F03FS02657
	Scoring saw blade	200	4,3-5,5	3,2	80	36	CON	8°	15°	2/14/110	<b>LI25M43PL3</b>	F03FS02683
	Postforming scorer	300	4,7	3,2	80	72	ATB	15°	15°	2/14/110	<b>LI27M DC3</b>	F03FS02741

\* Tool type - Tip alata

Main saw blade / Glavna testera, Scoring saw blade / Predrezač, Postforming scorer / Predrezač za postforming

# Reference table of saw blades for panel sizing machines

## Referentna tabela testera za formatizere

Machine type Tip mašine	Tool type * Tip alata*	D mm	B-B1 mm	b mm	d mm	Z	Tooth type Tip zuba	$\alpha$	$\beta$	NL Pomoćni otvori	Code Šifra	SAP SAP
Impact 110	Main saw blade	400	4,4	3,2	80	72	TCG	15°	15°	4/9/100+2/9/110+2/14/110	LSB40012X	F03FS09173
	Scoring saw blade	160	4,3-5,5	3,2	55	36	CON	8°	15°	3/6/84+3/7/66	LI25M43LG3	F03FS02657
	Scoring saw blade	200	4,3-5,5	3,2	80	36	CON	8°	15°	2/14/110	LI25M43PL3	F03FS02683
	Postforming scorer	300	4,7	3,2	80	72	ATB	15°	15°	2/14/110	LI27M DC3	F03FS02741
<b>Selco</b>												
EB 70 (kit 80), 75 (Sektor 430), 80 (Sektor 450)	Main saw blade	320	4,4	3,2	65	60	TCG	15°	15°	2/9/110	LSB32003X	F03FS09161
	Main saw blade	320	4,4	3,2	65	72	TCG	15°	15°	2/9/110	LSB32001X	F03FS07805
	Scoring saw blade	200	4,3-5,5	3,2	65	36	CON	8°	15°	2/9/100+2/9/110	LI25M43PI3	F03FS02681
	Scoring saw blade	300	4,3-5,5	3,0	65	48	CON	12°	15°	2/9/100+2/9/110	LI25M43RX3	F03FS07616
	Postforming scorer	300	4,6	3,2	65	72	ATB	15°	15°	2/9/100+2/9/110	LI27M DA3	F03FS02737
WN2	Main saw blade	320	4,4	3,2	65	72	TCG	15°	15°	2/9/110	LSB32001X	F03FS07805
	Scoring saw blade	200	4,3-5,5	3,2	65	36	CON	8°	15°	2/9/100+2/9/110	LI25M43PI3	F03FS02681
EB 70 (L)	Main saw blade	300	4,4	3,0	65	60	TCG	15°	15°	2/9/110	LSB30002X	F03FS09159
	Scoring saw blade	200	4,3-5,5	3,2	65	36	ATB	8°	15°	2/9/100+2/9/110	LI25M43PI3	F03FS02681
	Scoring saw blade	300	4,3-5,5	3,0	65	48	CON	12°	15°	2/9/100+2/9/110	LI25M43RX3	F03FS07616
	Postforming scorer	300	4,6	3,2	65	72	ATB	15°	15°	2/9/100+2/9/110	LI27M DA3	F03FS02737
EB 95, Sektor 470, SK470	Main saw blade	355	4,4	3,2	65	72	TCG	15°	15°	2/9/95 + 2/9/110	LSB35508X	F03FS08740
	Scoring saw blade	200	4,3-5,5	3,2	65	36	CON	8°	15°	2/9/100+2/9/110	LI25M43PI3	F03FS02681
	Scoring saw blade	300	4,3-5,5	3,0	65	48	CON	12°	15°	2/9/100+2/9/110	LI25M43RX3	F03FS07616
	Postforming scorer	300	4,6	3,2	65	72	ATB	15°	15°	2/9/100+2/9/110	LI27M DA3	F03FS02737
EB108, EB110, EB120	Main saw blade	400	4,4	3,2	80	72	TCG	15°	15°	2/15/105+2/9/130+4/19/120	LSB40009X	F03FS07810
	Scoring saw blade	200	4,3-5,5	3,2	65	36	CON	8°	15°	2/9/100+2/9/110	LI25M43PI3	F03FS02681
	Scoring saw blade	300	4,3-5,5	3,0	65	48	CON	12°	15°	2/9/100+2/9/110	LI25M43RX3	F03FS07616
	Postforming scorer	300	4,6	3,2	65	72	ATB	15°	15°	2/9/100+2/9/110	LI27M DA3	F03FS02737
EB/EBT 120, WN 125	Main saw blade	430	4,4	3,2	80	72	TCG	15°	15°	2/14/110+4/19/120+2/9/130	LSB43009X	F03FS07909
	Scoring saw blade	200	4,3-5,5	3,2	65	36	CON	8°	15°	2/9/100+2/9/110	LI25M43PI3	F03FS02681
	Scoring saw blade	300	4,3-5,5	3,2	65	72	CON	12°	15°	2/9/110	LI25M43RI3	F03FS02689
	Postforming scorer	300	4,6	3,2	65	72	ATB	15°	15°	2/9/100+2/9/110	LI27M DA3	F03FS02737
EB100	Main saw blade	360	4,4	3,2	65	72	TCG	15°	15°	2/9/110	LSB36002X	F03FS07673
	Scoring saw blade	200	4,3-5,5	3,2	65	36	CON	8°	15°	2/9/100+2/9/110	LI25M43PI3	F03FS02681
	Scoring saw blade	300	4,3-5,5	3,0	65	48	CON	12°	15°	2/9/100+2/9/110	LI25M43RX3	F03FS07616
	Postforming scorer	300	4,6	3,2	65	72	ATB	15°	15°	2/9/100+2/9/110	LI27M DA3	F03FS02737
WN 600/132, WN 200	Main saw blade	450	4,8	3,5	80	72	TCG	15°	15°	2/9/130+4/19/120	LSB45018X	F03FS07812
	Scoring saw blade	200	4,7-5,9	3,5	65	36	CON	8°	15°	2/9/100+2/9/110	LI25M47PI3	F03FS02720
	Postforming scorer	300	5,0	3,0	65	72	ATB	15°	15°	2/9/100+2/9/110	LI27M DB3	F03FS02739
WNA600/162	Main saw blade	510	4,8	3,5	80	72	TCG	15°	15°	2/9/130+4/19/120	LSB51001	F03FS06220
	Scoring saw blade	200	4,7-5,9	3,5	65	36	CON	8°	15°	2/9/100+2/9/110	LI25M47PI3	F03FS02720
	Postforming scorer	300	5,0	3,0	65	72	ATB	15°	15°	2/9/100+2/9/110	LI27M DB3	F03FS02739
WN 600/145, WN 512	Main saw blade	480	4,8	3,5	80	72	TCG	15°	15°	2/9/130+4/19/120	LSB48001X	F03FS09188
	Scoring saw blade	200	4,7 - 5,9	3,5	65	36	CON	8°	15°	2/9/100 + 2/9/110	LI25M47PI3	F03FS02720
	Postforming scorer	300	4,6	3,2	65	72	ATB	15°	15°	2/9/100+2/9/110	LI27M DA3	F03FS02737
WN 610, WN 630 (PFS)	Main saw blade	380	4,4	3,2	65	72	TCG	15°	15°	2/9/110	LSB38014X	F03FS09166
	Scoring saw blade	200	4,3-5,5	3,2	65	36	CON	8°	15°	2/9/100+2/9/110	LI25M43PI3	F03FS02681
	Scoring saw blade	300	4,3-5,5	3,0	65	48	CON	12°	15°	2/9/100+2/9/110	LI25M43RX3	F03FS07616

# Reference table of saw blades for panel sizing machines

## Referentna tabela testera za formatizere

Machine type Tip mašine	Tool type * Tip alata*	D mm	B-B1 mm	b mm	d mm	Z	Tooth type Tip zuba	$\alpha$	$\beta$	NL Pomoćni otvori	Code Šifra	SAP SAP
<b>WN 630, WN 630 (PFS)</b>	Main saw blade	400	4,4	3,2	65	72	TCG	15°	15°	2/9/110	<b>LSB40016X</b>	F03FS09172
	Scoring saw blade	200	4,3 - 5,5	3,2	65	36	CON	8°	15°	2/9/100 + 2/9/110	<b>LI25M43PI3</b>	F03FS02681
	Scoring saw blade	300	4,3 - 5,5	3,0	65	48	CON	12°	15°	2/9/100 + 2/9/110	<b>LI25M43RX3</b>	F03FS07616
<b>WN 650, WN 650 (PFS)</b>	Main saw blade	430	4,4	3,2	65	72	TCG	15°	15°	2/9/110	<b>LSB43012X</b>	F03FS09178
	Scoring saw blade	200	4,3 - 5,5	3,2	65	36	CON	8°	15°	2/9/100 + 2/9/110	<b>LI25M43PI3</b>	F03FS02681
	Scoring saw blade	300	4,3 - 5,5	3,0	65	48	CON	12°	15°	2/9/100 + 2/9/110	<b>LI25M43RX3</b>	F03FS07616
<b>WN 710, WN 710 (PFS)</b>	Main saw blade	430	4,8	3,5	70	72	TCG	15°	15°	4/11/130	<b>LSB43013X</b>	F03FS09180
	Scoring saw blade	200	4,7 - 5,9	3,5	65	36	CON	8°	15°	2/9/100 + 2/9/110	<b>LI25M47PI3</b>	F03FS02720
	Scoring saw blade	300	4,7 - 5,9	3,5	65	48	CON	12°	15°	2/9/100 + 2/9/110	<b>LI25M47RX3</b>	F03FS07744
<b>WN 730, WN 730 (PFS)</b>	Main saw blade	470	4,8	3,5	70	72	TCG	15°	15°	4/11/130	<b>LSB47005X</b>	F03FS09185
	Scoring saw blade	200	4,7 - 5,9	3,5	65	36	CON	8°	15°	2/9/100 + 2/9/110	<b>LI25M47PI3</b>	F03FS02720
	Scoring saw blade	300	4,7 - 5,9	3,5	65	48	CON	12°	15°	2/9/100 + 2/9/110	<b>LI25M47RX3</b>	F03FS07744
<b>WN 750, WN 750 (PFS)</b>	Main saw blade	470	4,8	3,5	70	72	TCG	15°	15°	4/11/130	<b>LSB47005X</b>	F03FS09185
	Main saw blade	520	4,8	3,5	70	72	TCG	15°	15°	4/11/130	<b>LSB52006X</b>	F03FS09193
	Scoring saw blade	200	4,7 - 5,9	3,5	65	36	CON	8°	15°	2/9/100 + 2/9/110	<b>LI25M47PI3</b>	F03FS02720
<b>WN 830, WN 850</b>	Main saw blade	600	5,8	4,0	75	60	TCG	15°	15°	4/11/130	<b>LSB60006</b>	F03FS09107
	Scoring saw blade	200	5,7 - 6,9	3,5	65	36	CON	8°	15°	2/9/110	<b>LI25M57PI3BS</b>	F03FS08165
<b>SCM - Techmatic</b>												
<b>FIT 45/FIT 2,9/ PRIMEX</b>	Main saw blade	250	4,2	3,0	55	60	TCG	15°	15°	4/10/70	<b>LSB25002</b>	F03FS07366
	Scoring saw blade	115	4,1 - 5,2	2,8	45	24	CON	0°	15°		<b>LI25M41DE3</b>	F03FS08039
<b>STAR 3,4</b>	Main saw blade	270	4,2	3,0	55	60	TCG	15°	15°		<b>LSB27001</b>	F03FS08037
	Scoring saw blade	115	4,1 - 5,2	2,8	45	24	CON	0°	15°		<b>LI25M41DE3</b>	F03FS08039
<b>STAR/FIT 60</b>	Main saw blade	290	4,2	3,0	55	60	TCG	15°	15°		<b>LSB29001</b>	F03FS08038
	Scoring saw blade	115	4,1 - 5,2	2,8	45	24	CON	0°	15°		<b>LI25M41DE3</b>	F03FS08039
<b>Usikraft</b>												
<b>SPEADY EVOLUTION 2900</b>	Main saw blade	250	4,2	3,0	50	60	TCG	15°	15°		<b>LSB25005</b>	F03FS08159
	Scoring saw blade	110	4,1 - 5,2	2,8	45	24	CON	0°	15°		<b>LSI25M41CE3</b>	F03FS087365
<b>AGILE FLEX 2900</b>	Main saw blade	220	3,2	2,2	50	64	TCG	15°	15°		<b>LU3D 0202</b>	F03FS08160
	Scoring saw blade	115	3,1 - 4,2	2,2	45	24	CON	0°	15°		<b>LI25M31DC3</b>	F03FS09242
<b>Verry</b>												
<b>GOLDEN AUTOMATIC</b>	Main saw blade	300	4,4	3,2	30	72	TCG	10°	15°	2/10/60	<b>LSB30005</b>	F03FS30920
	Scoring saw blade	150	4,3 - 5,6	3,2	30	36	CON	8°	15°		<b>LI25M43KC3</b>	F03FS02649
<b>MAX</b>	Main saw blade	250	4,2	3,0	30	60	TCG	15°	15°	2/10/60	<b>LSB25003</b>	F03FS07367
	Scoring saw blade	115	4,1 - 5,2	2,8	45	24	CON	0°	15°		<b>LI25M41DE3</b>	F03FS08039
<b>Wonpoong</b>												
<b>WARSM- 2000/3000/3500/ 4000L/5000L</b>	Main saw blade	380	4,4	3,2	75	72	TCG	15°	15°	2/14/100	<b>LSB38012X</b>	F03FS07672
	Scoring saw blade	175	4,3 - 5,5	3,2	75	36	CON	8°	15°		<b>LI25M43WT3</b>	F03FS07816
	Scoring saw blade	180	4,3 - 5,5	3,2	75	36	CON	8°	15°		<b>LI25M43NT3</b>	F03FS07286

\* Tool type - Tip alata

Main saw blade / Glavna testera, Scoring saw blade / Predrezač, Postforming scorer / Predrezač za postforming



## HW - Panel sizing saw blades TM - Testere za formatizere

To size single or multiple panels.

**Machines:** Horizontal panel sizing machines with scorer.

**Features:** Flat-triple chip tooth with positive cutting angle. **The LSB Extended deliver increased durability per sharpening cycle, due to the latest improvements in the production process. Advanced technology implementation to deliver a superior performance in the panel sizing applications.**

**Material:** Chipboard or MDF laminated with melamine or plastic materials.

Testere za rezanje jednog ili više panela. LSB X testere (oznaka X predstavlja izraz EXTENDED tj. PRODUŽEN) su testere povećane otpornosti koje imaju duži radni vek do oštrenja, zahvaljujući najsavremenijim poboljšanjima u procesu proizvodnje. Napredna tehnologija izrade omogućava superiorne performanse prilikom rezanja panela.

**Mašine:** Horizontalni formatizeri sa predrezačem.

**Oblik zuba:** Kombinacija ravnog i piramidalnog zuba sa pozitivnim uglom rezanja.

**Materijal:** Iverica ili medijapan (MDF) sa melaminskom ili plastičnom folijom.

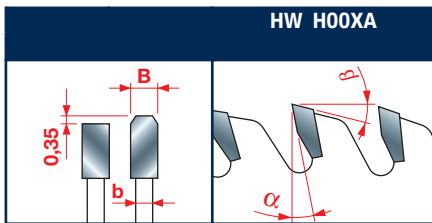
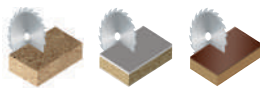

Tooth features - Karakteristike zuba

GATECH  
www.freud.rs

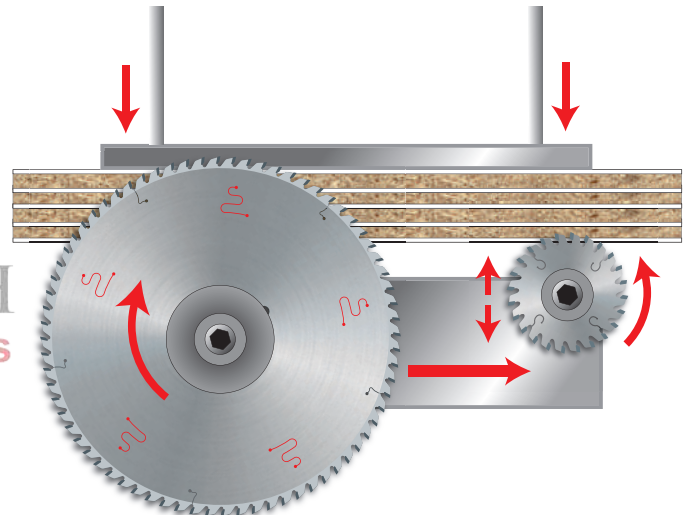

	D	B	b	d	Z	$\alpha$	$\beta$	NL	Machines	Code	SAP
	mm	mm	mm	mm				Pomoćni otvori	Mašine	Šifra	SAP
	300	4,4	3,0	30	60	15°	15°	2/10/60	Panhans	LSB30001X	F03FS07802
novo	300	4,4	3,0	65	60	15°	15°	2/9/110	Selco	LSB30002X	F03FS09159
novo	300	4,4	3,0	80	60	15°	15°	4/9/100+2/14/110	SCM	LSB30004X	F03FS09157
	300	4,4	3,0	30	72	15°	15°	2/10/60	Panhans, Verry	LSB30005X	F03FS07803
novo	300	4,4	3,0	65	72	15°	15°	2/9/110	Selco	LSB30006X	F03FS09158
	300	4,4	3,0	80	72	15°	15°	4/9/100 + 2/14/110	SCM	LSB30008X	F03FS07804
	300	4,4	3,2	60	72	15°	15°	2/14/100	Holzma	LSB30012X	F03FS09207
novo	320	4,4	3,2	30	60	15°	15°			LSB32005X	F03FS09160
novo	320	4,4	3,2	65	60	15°	15°	2/9/110	Selco	LSB32003X	F03FS09161
	320	4,4	3,2	65	72	15°	15°	2/9/110	Selco	LSB32001X	F03FS07805
novo	320	4,4	3,2	75	72	15°	15°	3/13/95 + 3/7/100	Giben	LSB32002X	F03FS09162
	350	4,4	3,2	30	72	15°	15°	2/10/60	Panhans, Scheer	LSB35003X	F03FS07630
	350	4,4	3,2	50	72	15°	15°	4/13/80	Giben	LSB35006X	F03FS07709
	350	4,4	3,2	60	72	15°	15°	2/14/100	Holzma	LSB35004X	F03FS07636
	350	4,4	3,2	75	72	15°	15°		Giben, Hansol Machine	LSB35008X	F03FS07634
	350	4,4	3,2	80	72	15°	15°	4/9/100 + 2/9/110 + 2/14/110	Gabbiani	LSB35005X	F03FS07635
novo	355	4,4	3,2	80	54	15°	15°	4/9/100+2/9/110+2/14/110	Gabbiani	LSB35503X	F03FS09205
	355	4,4	3,2	30	72	15°	15°	2/10/60	Panhans, SCM	LSB35504X	F03FS07674
	355	4,4	3,2	65	72	15°	15°	2/9/95 + 2/9/110	Selco	LSB35508X	F03FS08740
	355	4,4	3,2	75	72	15°	15°	4/15/105 + 2/7/110	Giben, KDT, Hold	LSB35505X	F03FS07633
	355	4,4	3,2	75	72	15°	15°	3/7/100	Gabbiani	LSB35507X	F03FS07710
novo	355	4,4	3,2	80	72	15°	15°	4/9/100+2/9/110+2/14/110	Gabbiani	LSB35506X	F03FS09163
	360	4,4	3,2	65	72	15°	15°	2/9/110	Selco	LSB36002X	F03FS07673
novo	380	4,4	3,2	80	48	15°	15°	4/9/100+2/9/110+2/14/110	Gabbiani	LSB38009X	F03FS09164
	380	4,4	3,2	60	60	15°	15°	2/14/100	Holzma	LSB38001X	F03FS07806
novo	380	4,4	3,2	50	72	15°	15°	4/13/80	Giben	LSB38008X	F03FS09165
	380	4,4	3,2	60	72	15°	15°	2/14/100	Holzma	LSB38002X	F03FS07631
novo	380	4,4	3,2	65	72	15°	15°	2/9/110	Selco	LSB38014X	F03FS09166
	380	4,4	3,2	75	72	15°	15°	2/14/100	Holzma wp, Wonpoong	LSB38012X	F03FS07672
	380	4,4	3,2	80	72	15°	15°	4/9/100 + 2/9/110 + 2/14/110	Gabbiani	LSB38010X	F03FS07808



	D mm	B mm	b mm	d mm	Z	α	β	NL Pomoćni otvori	Machines Mašine	Code Šifra	SAP SAP
	380	4,4	3,2	60	84	15°	15°	2/14/100	Holzma	LSB38015X	F03FS08989
	380	4,4	3,2	80	96	15°	15°	4/9/100 + 2/9/110 + 2/14/110	Gabbiani	LSB38013X	F03FS07809
	380	4,8	3,5	60	72	15°	15°	2/14/100	Holzma	LSB38004X	F03FS07632
	380	4,8	3,5	60	84	15°	15°	2/14/100	Holzma	LSB38005X	F03FS07807
novo	390	4,4	3,2	80	72	15°	15°	2/14/110	Sigma	LSB39001X	F03FS09167
novo	400	4,4	3,2	30	48	15°	15°			LSB40001X	F03FS09168
novo	400	4,4	3,2	30	60	15°	15°	2/10/60		LSB40004X	F03FS09169
novo	400	4,4	3,2	75	60	15°	15°	4/15/105	Giben	LSB40005X	F03FS09170
novo	400	4,4	3,2	80	60	15°	15°	4/9/100 + 2/9/110 + 2/14/110	Gabbiani	LSB40011X	F03FS09171
	400	4,4	3,2	30	72	15°	15°	2/10/60+2/13/94	Scheer	LSB40007X	F03FS07725
novo	400	4,4	3,2	65	72	15°	15°	2/9/110	Selco	LSB40016X	F03FS09172
	400	4,4	3,2	75	72	15°	15°	4/15/105 + 2/7/110	Giben, Haisung Woodworking Machinery, Hansol Machine, HOMAG, Hyundai Sangi, KDT	LSB40008X	F03FS07726
	400	4,4	3,2	80	72	15°	15°	2/15/105 + 2/9/130 + 4/19/120	Selco, MAS	LSB40009X	F03FS07810
novo	400	4,4	3,2	80	72	15°	15°	4/9/100 + 2/9/110 + 2/14/110	Gabbiani	LSB40012X	F03FS09173
	400	4,4	3,2	75	84	15°	15°	4/15/105 + 2/7/110	KDT	LSB40019X	F03FS08990
	400	4,8	3,5	60	72	15°	15°	2/14/125	Holzma	LSB40013X	F03FS07711
novo	420	4,4	3,2	50	72	15°	15°	2/9/130 + 4/19/120	Selco	LSB42006X	F03FS09174
novo	420	4,4	3,2	80	72	15°	15°	4/9/100 + 2/9/110 + 2/14/110	Gabbiani	LSB42005X	F03FS09175
novo	420	4,8	3,5	60	84	15°	15°	2/14/100 + 2/14/125	Holzma	LSB42002X	F03FS09176
novo	430	4,4	3,2	30	72	15°	15°			LSB43007X	F03FS09177
novo	430	4,4	3,2	65	72	15°	15°	2/9/110	Selco	LSB43012X	F03FS09178
	430	4,4	3,2	75	72	15°	15°	4/15/105 + 2/7/110	Giben	LSB43008X	F03FS07908
	430	4,4	3,2	80	72	15°	15°	2/9/130 + 2/14/110 + 4/19/120	Selco, Gabbiani	LSB43009X	F03FS07909
novo	430	4,4	3,2	75	96	15°	15°	4/15/105 + 2/7/110	Giben Prismatic	LSB43010X	F03FS09179
novo	430	4,8	3,5	70	72	15°	15°	4/11/130	Selco	LSB43013X	F03FS09180
novo	450	4,4	3,2	30	72	15°	15°	2/10/60 + 2/14/95	Mayer, Panhans, SCM	LSB45007X	F03FS09181
novo	450	4,4	3,2	60	72	15°	15°	2/14/125	Holzma	LSB45008X	F03FS09182
	450	4,4	3,2	80	72	15°	15°	2/9/130 + 2/14/110 + 4/19/120	Selco, Gabbiani	LSB45009X	F03FS07811
	450	4,8	3,5	60	72	15°	15°	2/14/125 + 2/17/100	Holzma, Nanxing	LSB45017X	F03FS07391
	450	4,8	3,5	80	72	15°	15°	2/9/130 + 4/19/120	Selco	LSB45018X	F03FS07812
novo	460	4,4	3,2	30	72	15°	15°	2/13/94	Schelling	LSB46001X	F03FS08922
novo	460	4,4	3,2	75	72	15°	15°	2/7/110	Giben	LSB46002X	F03FS07914
novo	470	4,4	3,2	75	72	15°	15°	4/15/105	Giben, Hyundai Sangi	LSB47003X	F03FS09183
novo	470	4,4	3,2	75	96	15°	15°	4/15/105	Giben	LSB47004X	F03FS09184
novo	470	4,8	3,5	70	72	15°	15°	4/11/130	Selco	LSB47005X	F03FS09185
novo	480	4,8	3,5	80	60	15°	15°	2/9/130 + 4/19/120	Selco	LSB48003X	F03FS09186
novo	480	4,8	3,5	30	72	15°	15°	2/10/60 + 2/13/94	Schelling	LSB48004X	F03FS09187
novo	480	4,8	3,5	80	72	15°	15°	2/9/130 + 4/19/120	Selco	LSB48001X	F03FS09188
novo	500	4,8	3,5	60	60	15°	15°	2/11/115	Holzma	LSB50009X	F03FS09189
novo	500	4,8	3,5	75	60	15°	15°	4/15/105	Giben	LSB50010X	F03FS09190
novo	500	4,8	3,5	60	72	15°	15°	2/11/115	Holzma	LSB50011X	F03FS09191
novo	520	4,8	3,5	60	72	15°	15°	2/11/115 + 2/19/120	Holzma	LSB52003X	F03FS09192
novo	520	4,8	3,5	70	72	15°	15°	4/11/130	Selco	LSB52006X	F03FS09193
novo	530	5,2	3,5	30	60	15°	15°		Schelling	LSB53001X	F03FS09194
novo	530	5,2	3,5	100	60	15°	15°	2/7/140		LSB53003X	F03FS09195
novo	550	5,0	3,5	40	72	15°	15°	2/13/122	Schelling	LSB55007X	F03FS09216
novo	550	5,2	3,5	60	60	15°	15°			LSB55002X	F03FS09196
novo	550	5,2	3,5	80	60	15°	15°	2/14/110	Gabbiani	LSB55006X	F03FS09197
novo	565	5,0	3,5	100	72	15°	15°		Giben	LSB56504X	F03FS09215
novo	565	5,2	3,5	100	60	15°	15°		Giben	LSB56502X	F03FS09198
novo	570	4,8	3,5	60	60	15°	15°	2/11/115 + 2/19/120	Holzma	LSB57001X	F03FS09199
novo	600	5,8	4,0	60	60	15°	15°	2/11/115 + 2/19/120	Holzma Typ 33	LSB60001X	F03FS09200
novo	600	5,8	4,0	60	72	15°	15°	2/11/115 + 2/19/120	Holzma Typ 33	LSB60002X	F03FS09201
novo	670	6,2	4,2	40	60	18°	13°	2/17/140 + 2/13/140	Schelling	LSB67003X	F03FS09202
novo	680	6,2	4,2	40	60	18°	13°	2/13/140 + 2/17/140 + 2/13/114	Schelling	LSB68001X	F03FS09203
novo	720	6,4	4,4	40	60	18°	13°	2/14/114 + 2/14/140	Schelling	LSB72001X	F03FS09204

GATECH  
www.freud.rs

## HW - Panel sizing saw blades TM - Testere za formatizere

To size single or multiple panels.

**Machines:** Horizontal panel sizing machines with scorer.

**Features:** Flat-triple chip tooth with positive cutting angle.

**Material:** Chipboard or MDF laminated with melamine or plastic materials.

Testere za rezanje jednog ili više panela (tabli).

**Mašine:** Horizontalni formatizeri sa predrežačem.

**Oblik zuba:** Kombinacija ravnog i trapeznog zuba sa pozitivnim uglom rezanja.

**Materijal:** Iverica i medijapan (MDF) sa melaminskom ili plastičnom folijom.

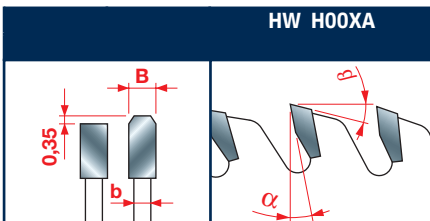
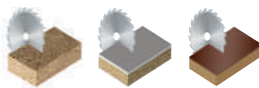

Tooth features - Karakteristike zuba



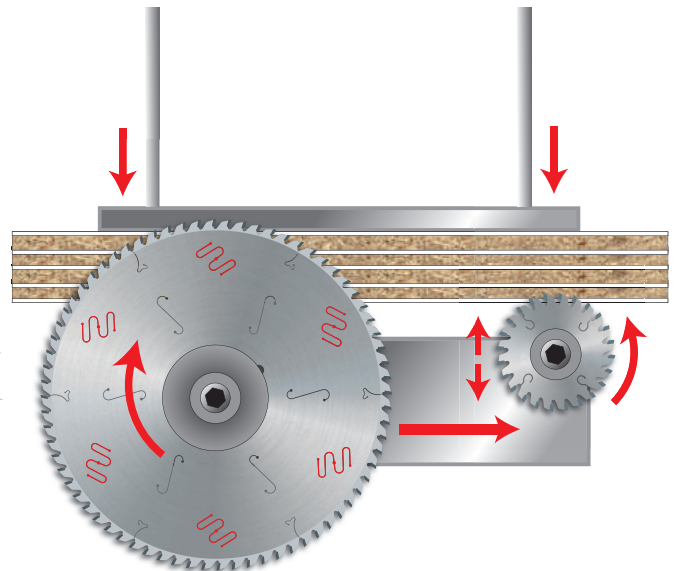





















































GATECH  
www.freud.rs



	D	B	b	d	Z	$\alpha$	$\beta$	NL	Machines	Code	SAP
	mm	mm	mm	mm				Pomoćni otvori	Mašine	Šifra	SAP
	250	4,2	3,0	55	48	15°	15°		SCM - Techmatic	LSB25001	F03FS06974
	250	4,2	3,0	30	60	15°	15°		SCM - Techmatic, Verry	LSB25003	F03FS07367
novo	250	4,2	3,0	50	60	15°	15°	-	Usikraft	LSB25005	F03FS08159
	250	4,2	3,0	55	60	15°	15°		Baldan, SCM - Techmatic	LSB25002	F03FS07366
	250	4,4	3,0	30	80	15°	15°	2/9/46,4 + 2/10/60		LSB25004	F03FS07372
novo	270	4,2	3,0	55	60	15°	15°		SCM - Techmatic	LSB27001	F03FS08037
novo	280	4,4	3,2	55	60	10°	15°	2/10/70	Baldan	LSB28001	F03FS08161
novo	290	4,2	3,0	55	60	15°	15°	-	SCM - Techmatic	LSB29001	F03FS08038
	300	4,4	3,0	30	60	10°	15°	2/10/60	Panhans	LSB30001	F03FS03912
	300	4,4	3,0	75	60	10°	15°		Homag	LSB30003	F03FS03916
	300	4,4	3,0	80	60	10°	15°	4/9/100 + 2/14/110	SCM	LSB30004	F03FS03918
	300	4,4	3,0	30	72	10°	15°	2/10/60	Panhans, Verry	LSB30005	F03FS03920
	300	4,4	3,0	65	72	10°	15°	2/9/110	Selco	LSB30006	F03FS03922
	300	4,4	3,0	75	72	10°	15°		Holzma	LSB30007	F03FS03924
	300	4,4	3,0	80	72	10°	15°	4/9/100 + 2/14/110	SCM	LSB30008	F03FS03926
	300	4,4	3,0	65	60	10°	15°	2/9/110	Selco	LSB30002	F03FS03914
	300	4,4	3,2	65	60	10°	15°	2/9/110	Selco	LSB30011	F03FS07743
	305	4,4	3,0	30	60	10°	15°	2/10/60	Mayer, Panhans, SCM	LSB30501	F03FS03930
	320	4,4	3,2	30	60	10°	15°			LSB32005	F03FS06570
	320	4,4	3,2	50	60	10°	15°	3/15/80 + 3/13/95	Giben	LSB32004	F03FS06569
	320	4,4	3,2	65	60	10°	15°	2/9/110	Selco	LSB32003	F03FS06027
	320	4,4	3,2	65	72	10°	15°	2/9/110	Selco	LSB32001	F03FS03931
	320	4,4	3,2	75	72	10°	15°	3/13/95 + 3/7/100	Giben	LSB32002	F03FS03933
novo	320	4,4	3,2	80	60	10°	15°	4/9/100+2/9/110+2/14/110		LSB32006	F03FS07907
	350	4,4	3,2	30	54	10°	15°	2/10/60	Panhans, Scheer	LSB35001	F03FS03935
	350	4,4	3,2	60	54	10°	15°	2/14/100	Holzma	LSB35002	F03FS03938
	350	4,4	3,2	30	72	10°	15°	2/10/60	Panhans, Scheer	LSB35003	F03FS03941
	350	4,4	3,2	50	72	10°	15°	4/13/80	Giben	LSB35006	F03FS03950
	350	4,4	3,2	60	72	10°	15°	2/14/100	Holzma	LSB35004	F03FS03944
	350	4,4	3,2	75	72	10°	15°		Giben	LSB35008	F03FS03954

D mm	B mm	b mm	d mm	Z	α	β	NL Pomoćni otvori	Machines Mašine	Code Šifra	SAP SAP
350	4,4	3,2	80	72	10°	15°	4/9/100+2/9/110+2/14/110	Gabbiani		LSB35005 F03FS03947
350	4,2	3,2	80	84	15°	15°				LSB35012 F03FS07548
350	4,2	3,2	80	96	15°	15°				LSB35011 F03FS07547
355	4,4	3,2	75	54	10°	15°		Giben		LSB35502 F03FS03961
355	4,4	3,2	80	54	10°	15°	4/9/100+2/9/110+2/14/110	Gabbiani		LSB35503 F03FS03964
355	4,4	3,2	30	72	10°	15°	2/10/60	Panhans, SCM		LSB35504 F03FS03967
355	4,4	3,2	65	72	15°	15°	2/9/110	Selco		LSB35508 F03FS07739
355	4,4	3,2	75	72	10°	15°	4/15/105 + 2/7/110	Homag - Giben		LSB35505 F03FS03970
355	4,4	3,2	75	72	10°	15°	3/7/100	Gabbiani		LSB35507 F03FS03976
355	4,4	3,2	80	72	10°	15°	4/9/100+2/9/110+2/14/110	Gabbiani		LSB35506 F03FS03973
360	4,4	3,0	65	60	10°	15°	2/9/110	Selco		LSB36001 F03FS03978
360	4,4	3,2	65	72	10°	15°	2/9/110	Selco		LSB36002 F03FS03981
370	4,4	3,2	30	72	10°	15°	2/10/60	Schelling		LSB37001 F03FS03984
380	4,4	3,2	80	48	10°	15°	4/9/100+2/9/110+2/14/110	Gabbiani		LSB38009 F03FS04006
380	4,4	3,2	50	60	10°	15°	4/13/80	Giben		LSB38007 F03FS04000
380	4,4	3,2	60	60	10°	15°	2/14/100	Holzma		LSB38001 F03FS03986
380	4,4	3,2	30	72	10°	15°	2/8/83			LSB38011 F03FS08132
380	4,4	3,2	50	72	10°	15°	4/13/80	Giben		LSB38008 F03FS04003
380	4,4	3,2	60	72	10°	15°	2/14/100	Holzma		LSB38002 F03FS03989
380	4,4	3,2	65	72	10°	15°	2/9/110	Selco		LSB38014 F03FS07266
380	4,4	3,2	75	72	10°	15°	2/14/100	Holzma		LSB38012 F03FS05805
380	4,4	3,2	80	72	10°	15°	4/9/100+2/9/110+2/14/110	Gabbiani		LSB38010 F03FS04008
380	4,4	3,2	80	96	10°	15°	4/9/100+2/9/110+2/14/110	Gabbiani		LSB38013 F03FS06258
380	4,8	3,5	60	60	10°	15°	2/14/100	Holzma		LSB38003 F03FS03992
380	4,8	3,5	60	72	10°	15°	2/14/100	Holzma		LSB38004 F03FS03994
380	4,8	3,5	60	84	10°	15°	2/14/100	Holzma		LSB38005 F03FS03996
390	4,4	3,2	80	72	10°	15°	2/14/110	Sigma		LSB39001 F03FS04010
400	4,4	3,2	30	48	10°	15°				LSB40001 F03FS04011
400	4,4	3,2	75	48	15°	15°	4/15/105	Giben		LSB40002 F03FS04013
400	4,4	3,2	80	48	15°	15°	2/9/110+4/9/100+2/14/110	Gabbiani		LSB40010 F03FS04035
400	4,4	3,2	30	60	15°	15°	2/10/60			LSB40004 F03FS04017
400	4,4	3,2	75	60	15°	15°	4/15/105	Giben		LSB40005 F03FS04020
400	4,4	3,2	80	60	15°	15°	2/9/130 + 4/19/120	Selco		LSB40006 F03FS04023
400	4,4	3,2	80	60	15°	15°	4/9/100+2/9/110+2/14/110	Gabbiani		LSB40011 F03FS04037
400	4,4	3,2	30	72	10°	15°	2/10/60	Scheer		LSB40007 F03FS04026
400	4,4	3,2	65	72	15°	15°	2/9/110	Selco		LSB40016 F03FS07740
400	4,4	3,2	75	72	10°	15°	4/15/105 + 2/7/110	Homag - Giben		LSB40008 F03FS04029
400	4,4	3,2	80	72	10°	15°	2/9/130 + 4/19/120 + 2/15/105	Selco		LSB40009 F03FS04032
400	4,4	3,2	80	72	10°	15°	4/9/100+2/9/110+2/14/110	Gabbiani		LSB40012 F03FS04040
400	4,6	3,2	35	72	10°	15°		Euromac		LSB40015 F03FS05981
400	4,8	3,5	60	72	10°	15°		Holzma		LSB40013 F03FS04043
420	4,4	3,2	80	60	10°	15°	4/9/100+2/9/110+2/14/110	Gabbiani		LSB42004 F03FS06028
420	4,4	3,2	50	72	10°	15°	4/13/80	Giben		LSB42006 F03FS06544
420	4,4	3,2	80	72	10°	15°	4/9/100+2/9/110+2/14/110	Gabbiani		LSB42005 F03FS06029
420	4,8	3,5	60	60	15°	15°	2/14/125	Holzma		LSB42001 F03FS04045
420	4,8	3,5	60	84	10°	15°	2/14/100+2/14/125	Holzma		LSB42002 F03FS04048
430	4,4	3,2	30	48	15°	15°				LSB43001 F03FS04050
430	4,4	3,2	75	48	15°	15°	4/15/105	Giben		LSB43002 F03FS04052
430	4,4	3,2	30	60	15°	15°	2/10/60			LSB43004 F03FS04057
430	4,4	3,2	75	60	15°	15°	4/15/105	Giben		LSB43005 F03FS04059
430	4,4	3,2	80	60	15°	15°	2/9/130+2/14/110+4/19/120	Selco - Gabbiani		LSB43006 F03FS04062
430	4,4	3,2	30	72	15°	15°				LSB43007 F03FS04065
430	4,4	3,2	65	72	10°	15°	2/9/110	Selco		LSB43012 F03FS07457
430	4,4	3,2	75	72	10°	15°	4/15/105 + 2/7/110	Homag, Giben		LSB43008 F03FS04068
430	4,4	3,2	80	72	10°	15°	2/9/130+2/14/110+4/19/120	Selco - Gabbiani		LSB43009 F03FS04071
430	4,4	3,2	75	96	10°	15°	4/15/105 + 2/7/110	Giben Prismatic		LSB43010 F03FS04074
430	4,8	3,5	70	72	15°	15°	4/11/130	Selco		LSB43013 F03FS07741
450	4,4	3,2	30	48	15°	15°	2/9/60	Mayer, Panhans, SCM		LSB45001 F03FS04076
450	4,4	3,2	60	48	15°	15°	2/14/125	Holzma		LSB45002 F03FS04078
450	4,4	3,2	80	48	15°	15°	2/9/130+4/19/120+2/14/110	Selco - Gabbiani		LSB45003 F03FS04080

GATECH  
www.freud.rs

D mm	B mm	b mm	d mm	Z	$\alpha$	$\beta$	NL Pomoćni otvori	Machines Mašine	Code Šifra	SAP SAP		
450	4,4	3,2	30	60	15°	15°	02/10/60	Mayer, Panhans, SCM		LSB45004	F03FS04083	
450	4,4	3,2	60	60	15°	15°	2/14/125	Holzma		LSB45005	F03FS04085	
450	4,4	3,2	80	60	10°	15°	2/9/130+4/19/120+2/14/110	Selco - Gabbiani		LSB45006	F03FS04087	
450	4,4	3,2	30	72	10°	15°	2/10/60 + 2/14/95	Mayer, Panhans, SCM		LSB45007	F03FS04090	
450	4,4	3,2	60	72	10°	15°	2/14/125	Holzma		LSB45008	F03FS04092	
450	4,4	3,2	80	72	10°	15°	2/9/130+2/14/110+4/19/120	Selco - Gabbiani		LSB45009	F03FS04095	
450	4,8	3,5	30	72	10°	15°	02/09/60	Scheer		LSB45016	F03FS04109	
450	4,8	3,5	60	72	10°	15°	2/14/125 + 2/17/100	Holzma		LSB45017	F03FS04111	
450	4,8	3,5	80	72	10°	15°	2/9/130 + 4/19/120	Selco		LSB45018	F03FS04114	
450	4,8	3,5	60	84	10°	15°	2/14/125	Holzma		LSB45019	F03FS06177	
460	4,4	3,2	30	72	10°	15°	2/13/94	Schelling		LSB46001	F03FS04117	
470	4,4	3,2	75	48	15°	15°	4/15/105	Giben		LSB47001	F03FS04120	
470	4,4	3,2	75	60	15°	15°	4/15/105	Giben		LSB47002	F03FS04123	
470	4,4	3,2	75	72	10°	15°	4/15/105	Giben		LSB47003	F03FS04126	
470	4,4	3,2	75	96	10°	15°	4/15/105	Giben		LSB47004	F03FS04129	
470	4,8	3,5	70	72	15°	15°	4/11/130	Selco		LSB47005	F03FS07742	
480	4,8	3,5	80	48	15°	15°	2/9/130+2/14/110+4/19/120	Selco - Gabbiani		LSB48002	F03FS04134	
480	4,8	3,5	80	60	15°	15°	2/9/130 + 4/19/120	Selco		LSB48003	F03FS04136	
480	4,8	3,5	30	72	10°	15°	2/10/60	Schelling		LSB48004	F03FS04138	
480	4,8	3,5	80	72	10°	15°	2/9/130 + 4/19/120	Selco		LSB48001	F03FS04131	
500	4,4	3,2	80	48	15°	15°	4/9/100+2/9/110+2/14/110	Gabbiani		LSB50002	F03FS04142	
500	4,4	3,2	30	60	15°	15°		Schelling		LSB50003	F03FS04145	
500	4,4	3,2	80	60	15°	15°	4/9/100+2/9/110+2/14/110	Gabbiani		LSB50004	F03FS04147	
500	4,4	3,2	30	72	15°	15°		Schelling		LSB50005	F03FS04150	
500	4,8	3,5	60	48	15°	15°	2/11/115	Holzma		LSB50007	F03FS04154	
500	4,8	3,5	60	60	15°	15°	2/11/115	Holzma		LSB50009	F03FS04158	
500	4,8	3,5	75	60	15°	15°	4/15/105	GIBEN		LSB50010	F03FS04160	
500	4,8	3,5	60	72	15°	15°	2/11/115	Holzma		LSB50011	F03FS04162	
500	4,8	3,5	75	72	15°	15°	4/15/105	Giben		LSB50012	F03FS04164	
510	4,8	3,5	80	72	15°	15°	2/9/130 + 4/19/120	Selco		LSB51001	F03FS06220	
520	4,4	3,2	30	54	15°	15°	2/13/94	Schelling		LSB52005	F03FS06799	
<b>novi</b>	520	4,8	3,5	30	72	18°	13°	2/13/94	Schelling		LSB52007	F03FS07878
520	4,8	3,5	60	60	15°	15°	2/11/115 + 2/19/120	Holzma		LSB52002	F03FS04168	
520	4,8	3,5	60	72	15°	15°	2/11/115 + 2/19/120	Holzma		LSB52003	F03FS04170	
520	4,8	3,5	70	72	18°	13°	4/11/130	Selco		LSB52006	F03FS07659	
530	5,2	3,5	30	60	15°	15°		Schelling		LSB53001	F03FS04172	
530	5,8	4,0	60	60	15°	15°	01/11/85	Anthon		LSB53002	F03FS04174	
540	4,8	3,5	60	60	15°	15°	2/11/115 + 2/19/120	Holzma Typ 33		LSB54002	F03FS04178	
540	4,8	3,5	60	72	15°	15°	2/11/115 + 2/19/120	Holzma Typ 33		LSB54003	F03FS04180	
540	5,8	4,0	60	60	15°	15°	01/11/85	Anthon		LSB54004	F03FS06030	
550	5,2	3,5	80	48	15°	15°	2/14/110	Gabbiani		LSB55005	F03FS04190	
550	5,2	3,5	60	60	15°	15°				LSB55002	F03FS04184	
550	5,2	3,5	80	60	15°	15°	2/14/110	Gabbiani		LSB55006	F03FS04192	
565	5,2	3,5	80	48	15°	15°	2/14/110 + 4/9/100	Gabbiani		LSB56503	F03FS04200	
565	5,2	3,5	100	48	15°	15°		Giben		LSB56501	F03FS04195	
565	5,2	3,5	100	60	15°	15°		Giben		LSB56502	F03FS04197	
570	4,8	3,5	60	60	15°	15°	2/11/115 + 2/19/120	Holzma		LSB57001	F03FS04203	
600	5,8	4,0	60	60	15°	15°	2/11/115 + 2/19/120	Holzma Typ 33		LSB60001	F03FS04207	
600	5,8	4,0	60	72	15°	15°	2/11/115 + 2/19/120	Holzma Typ 33		LSB60002	F03FS04210	
620	6,2	4,2	40	60	18°	13°	2/13/114 + 2/13/140	Schelling		LSB62001	F03FS04212	
620	6,2	4,2	40	72	15°	15°	2/13/114 + 2/13/140	Schelling		LSB62002	F03FS04213	
670	5,8	4,2	60	60	18°	13°	2/11/148 + 2/19/120	Holzma		LSB67001	F03FS04214	
670	5,8	4,2	60	72	15°	15°	2/11/148 + 2/19/120	Holzma		LSB67002	F03FS04215	
670	6,2	4,2	40	60	18°	13°	2/17/140 + 2/13/140	Schelling		LSB67003	F03FS04216	
670	6,2	4,2	40	72	15°	15°	2/17/140 + 2/13/140	Schelling		LSB67004	F03FS04217	
680	6,2	4,2	40	60	18°	13°	2/13/140 + 2/17/140	Schelling		LSB68001	F03FS04218	
700	6,2	4,2	80	60	18°	15°	2/17/110	Anthon LNC		LSB70001	F03FS07036	
720	6,4	4,4	40	60	18°	15°	2/14/114 + 2/14/140	Schelling		LSB72001	F03FS04219	
730	6,2	4,2	60	60	18°	15°	2/11/148 + 2/19/120	Holzma Typ 66		LSB73001	F03FS04220	

GATECH  
www.freud.rs



## HW - "Supercut" panel sizing saw blades with variable pitch TM - "Super-rez" testere za formatizere sa promenljivim korakom

To size single or multiple panels.

**Machines:** Horizontal panel sizing machines with scorer.

**Features:** Double triple chip tooth with positive cutting angle. Perfect for cutting at high feed rates to increase production throughput. Due to the precision cutting edge and resulting flawless finish no additional machining is needed before edge banding. The LSC Saw blade line was developed to achieve the highest possible feed rate with best possible finish available in the market. Performance = Productivity! Freud's exclusively patented vibration reduction reeds are strategically placed and engineered to give the greatest reduction in noise and vibration available in the market today. Benefits of the Technology result in a best in class performance for cutting both single sheets or stacked sheets on today's panel processing equipment.

**Material:** Chipboard or laminated wood composite materials.

Testere za rezanje jednog ili više panela (tabli).

**Mašine:** Horizontalni formatizeri sa predrezačem.

**Oblik zuba:** Trapezni zub sa pozitivnim uglom rezanja. Savršene za rezanje pri velikim brzinama ubacivanja i povećanje produktivnosti. Iza sebe ostavljaju precizan i savršen rez pa nema potrebe za dodatnom obradom ivica pre nanošenja kant trake. LSC grupa testera dizajnirana je da bi se postigla najveća brzina ubacivanja sa najboljim mogućim kvalitetom završnog reza na tržištu. Performanse = Produktivnost! Freudovi ekskluzivno patentirani antivibracioni otvori strateški su postavljeni tako da su buka i vibracija smanjene na najniži nivo na tržištu. Najsavremenija primenjena tehnologija rezultira najboljim performansama za rezanje kako pojedinačnih, tako i više panela odjednom.

**Materijal:** Iverica i oplemenjeni pločasti materijali.

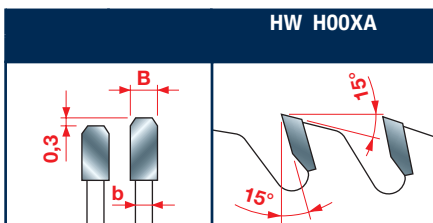
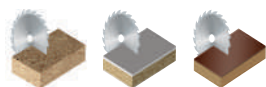

Tooth features - Karakteristike zuba

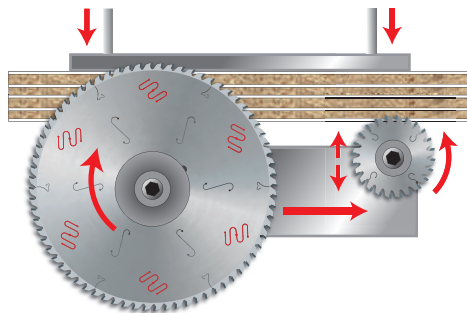

GATECH  
www.freud.rs

- \* Dedicated laser marking
- \* Laserske oznake

	D mm	B mm	b mm	d mm	Z	NL Pomoćni otvori	Machines Mašine	Code Šifra	SAP SAP
	300	4,4	3,0	30	60	2/10/60	Panhans	LSC30001	F03FS06322
	300	4,4	3,0	65	60	2/9/110	Selco	LSC30002	F03FS06325
	300	4,4	3,0	75	60		Holzma	LSC30003	F03FS06326
	300	4,4	3,0	80	60	2/14/110 + 4/9/100	SCM	LSC30004	F03FS06327
	320	4,4	3,2	50	60	3/15/80 + 3/13/95	Giben	LSC32004	F03FS06328
	320	4,4	3,2	65	60	2/9/110	Selco	LSC32003	F03FS06329
	350	4,4	3,2	30	72	2/10/60	Panhans-Scheer	LSC35003	F03FS06305
	350	4,4	3,2	50	72	4/13/80	Giben	LSC35006	F03FS06309
	350	4,4	3,2	60	72	2/14/100	Holzma	LSC35004	F03FS06310
	350	4,4	3,2	80	72	4/9/100 + 2/9/110 + 2/14/110	Gabbiani	LSC35005	F03FS06311
	355	4,4	3,2	30	72	2/10/60	Panhans-SCM	LSC35504	F03FS06306
novo	355	4,4	3,2	65	72	2/9/110		LSC35508BS*	F03FS07869
	355	4,4	3,2	75	72		Giben	LSC35505	F03FS06307
	360	4,4	3,2	65	72	2/9/110	Selco	LSC36002	F03FS06308
	370	4,4	3,2	30	72	2/10/60	Schelling	LSC37001	F03FS06312
	380	4,4	3,2	50	72	4/13/80	Giben	LSC38008	F03FS06343
	380	4,4	3,2	60	72	2/14/100	Holzma	LSC38002	F03FS06313
	380	4,4	3,2	80	72	4/9/100 + 2/9/110 + 2/14/110	Gabbiani	LSC38010	F03FS06314
	380	4,8	3,5	60	72	2/14/100	Holzma	LSC38004	F03FS06332
	400	4,4	3,2	30	72	2/10/60	Scheer	LSC40007	F03FS06315
novo	400	4,4	3,2	65	72	2/9/110		LSC40016BS*	F03FS07870
	400	4,4	3,2	75	72	4/15/105	Giben	LSC40008	F03FS06317
	400	4,4	3,2	80	72	4/19/120 + 2/9/130	Selco	LSC40009	F03FS06319
	400	4,4	3,2	80	72	4/9/100 + 2/9/110 + 2/14/110	Gabbiani	LSC40012	F03FS06320
	430	4,4	3,2	75	72	4/15/105	Giben	LSC43008	F03FS06316
	430	4,4	3,2	80	72	2/9/130 + 4/19/120 + 2/14/110	Selco-Gabbiani	LSC43009	F03FS06321
	450	4,4	3,2	60	72	2/14/125	Holzma	LSC45008	F03FS06318
	450	4,8	3,5	60	72	2/14/125	Holzma	LSC45017	F03FS06323
	450	4,8	3,5	80	72	2/9/130 + 4/19/120	Selco	LSC45018	F03FS06324
novo	520	4,8	3,5	30	72	2/13/94		LSC52007	F03FS07879



# LI25M

## HW - Conical scoring saw blades TM - Konusni predrezači

To score the coating on bilaminated panels.

**Machines:** Horizontal panel sizing machines that allow vertical adjustment of the scorer in relation to the panel sizing saw blade kerf.

**Features:** ATB 6° tooth with positive cutting angle.

**Material:** Bilaminated chipboard or MDF.

Za prosecanje folije na obostrano oplemenjenim pločastim materijalima.

**Mašine:** Horizontalni formatizeri bez podešavanja dubine prosecanja.

Maksimalna dubina prosecanja je 2mm.

**Oblik zuba:** ATB 6° sa pozitivnim uglom rezanja.

**Materijal:** Obostrano oplemenjena iverica ili MDF (medijapan).



GATECH  
www.freud.rs

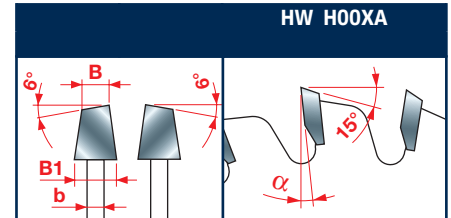

Tooth features - Karakteristike zuba

- \* Dedicated laser marking
- \* Laserske oznake

D mm	B - B1 mm	b mm	d mm	Z	$\alpha$	NL Pomoćni otvori	Machines Mašine	Code Šifra	SAP SAP
80	3,1 - 4,3	2,2	20	12	0°		Casadei	LI25M31AA3	F03FS02606
80	3,1 - 4,3	2,2	22	12	0°			LI25M31AB3	F03FS02608
100	3,1 - 4,3	2,5	20	20	0°			LI25M31BC3	F03FS06099
100	3,1 - 4,3	2,2	20	24	0°		Schelling	LI25M31BA3	F03FS02610
100	3,1 - 4,3	2,2	22	24	0°			LI25M31BB3	F03FS02612
110	3,1 - 4,3	2,2	20	24	0°			LI25M31CA3	F03FS02614
110	3,1 - 4,3	2,2	22	24	0°			LI25M31CB3	F03FS02615
115	3,1 - 4,3	2,2	20	24	0°			LI25M31DA3	F03FS02616
115	3,1 - 4,3	2,2	22	24	0°			LI25M31DB3	F03FS02618
120	2,8 - 4,0	2,2	20	24	0°		Schelling	LI25M28EA3	F03FS02604
120	2,8 - 4,0	2,2	22	24	0°			LI25M28EB3	F03FS02605
120	3,1 - 4,3	2,2	20	24	0°			LI25M31EA3	F03FS02620
120	3,1 - 4,3	2,2	22	24	0°			LI25M31EB3	F03FS02622
120	3,1 - 4,3	2,5	20	24	0°			LI25M31EC3	F03FS05978
120	3,4 - 4,6	2,2	20	24	0°		SCM	LI25M34EA3	F03FS02632
125	3,1 - 4,3	2,2	20	24	0°		Panhans-Schelling	LI25M31FA3	F03FS02623
125	3,1 - 4,3	2,2	22	24	0°		Martin	LI25M31FB3	F03FS02625
125	3,1 - 4,3	2,5	20	24	0°		Panhans-Schelling	LI25M31FC3	F03FS05932
125	3,4 - 4,6	2,2	20	24	0°			LI25M34FA3	F03FS02634
125	3,4 - 4,6	2,2	45	24	0°			LI25M34FE3	F03FS02636
125	4,3 - 5,5	3,2	20	24	0°		Panhans - Gabbiani	LI25M43FA3	F03FS02643
125	4,3 - 5,5	3,2	45	24	0°		Giben - Homag	LI25M43FE3	F03FS02645
125	4,5 - 5,7	3,0	20	24	0°			LI25M45FA3	F03FS02697
125	4,5 - 5,7	3,0	45	24	0°		Giben - Homag	LI25M45FE3	F03FS02699
140	3,1 - 4,3	2,2	16	28	8°	1/6/33	Scheer	LI25M31HM3	F03FS02627
140	3,4 - 4,7	3,0	45	24	8°			LI25M34HE3	F03FS02638
140	4,3 - 5,5	3,2	45	28	8°		Euromac	LI25M43HE3	F03FS02647
140	4,5 - 5,7	3,0	45	24	8°			LI25M45HE3	F03FS02701
145	4,3 - 5,5	3,2	45	30	8°		Hansol Machine	LI25M43WE3	F03FS08015
150	3,1 - 4,3	2,2	30	36	8°		SCM	LI25M31KC3	F03FS02628
150	3,4 - 4,7	2,2	30	36	8°		SCM	LI25M34KC3	F03FS02639
150	4,3 - 5,6	3,2	30	36	8°		SCM, Verry	LI25M43KC3	F03FS02649
150	4,3 - 5,6	3,2	45	36	8°		SCM, Holzma, Homag, Haisung Woodworking Machinery	LI25M43KE3	F03FS02651
150	4,5 - 5,8	3,0	30	36	8°		SCM	LI25M45KC3	F03FS02702
150	4,5 - 5,8	3,0	45	36	8°		SCM	LI25M45KE3	F03FS02704
160	3,1 - 4,3	2,2	20	36	8°		Langzauner	LI25M31LA3	F03FS02630
160	3,4 - 4,6	2,2	25,4	36	8°			LI25M34LR3	F03FS02641
160	4,3 - 5,5	3,2	25,4	36	8°			LI25M43LR3	F03FS02660
160	4,3 - 5,5	3,2	30	36	8°		Langzauner	LI25M43LC3	F03FS02653
160	4,3 - 5,5	3,2	45	36	8°	3/11/70	Giben	LI25M43LE3	F03FS02655
160	4,3 - 5,5	3,2	55	36	8°	3/6/84 + 3/7/66	Gabbiani - SCM	LI25M43LG3	F03FS02657
160	4,3 - 5,5	3,2	60	36	8°	3/7/80		LI25M43LH3	F03FS02659

novi

	D mm	B - B1 mm	b mm	d mm	Z	$\alpha$	NL Pomoćni otvori	Machines Mašine	Code Šifra	SAP SAP
	160	4,5 - 5,7	3,0	45	36	8°	3/11/70	Giben	LI25M45LE3	F03FS02706
	160	4,5 - 5,7	3,0	55	36	8°	3/7/66 + 3/9/72	Gabbiani	LI25M45LG3	F03FS02708
<b>novo</b>	175	4,3 - 5,5	3,2	75	36	8°		Wonpoong	LI25M43WT3	F03FS07816
	180	3,1 - 4,3	2,2	16	42	8°	1/6/33	Scheer	LI25M31NM3	F03FS02631
	180	3,4 - 4,6	2,2	25,4	36	8°			LI25M34NR3	F03FS02642
	180	4,3 - 5,5	3,2	20	28	8°		Schelling - Anthon	LI25M43NA3	F03FS02661
	180	4,3 - 5,5	3,2	30	28	8°	2/7/42 + 2/10/60	Panhans - Holzer	LI25M43NC3	F03FS02663
	180	4,3 - 5,5	3,2	20	36	8°		Schelling - Anthon	LI25M43XA3	F03FS06372
	180	4,3 - 5,5	3,2	30	36	8°	2/7/42 + 2/10/60	Holzher, Nanxing, KDT	LI25M43XN3	F03FS06373
	180	4,3 - 5,5	3,2	45	36	8°		Holzma	LI25M43NE3	F03FS02664
	180	4,3 - 5,5	3,2	50	36	8°	3/13/80	Giben	LI25M43NF3	F03FS02666
	180	4,5 - 5,7	3,0	20	36	8°		Schelling - Anthon	LI25M45NA3	F03FS02710
	180	4,7 - 5,9	3,5	45	36	8°		Holzma	LI25M47NE3	F03FS02715
	180	5,1 - 6,3	3,5	55	36	8°	3/7/66	Gabbiani	LI25M51NG3	F03FS02724
	180	5,7 - 6,9	4,0	20	36	8°		Anthon - Holzma	LI25M57NA3	F03FS02727
	200	4,3 - 5,5	3,2	20	36	8°	2/11/66 + 2/10/60 + 2/9/62	Schelling	LI25M43PA3	F03FS02670
	200	4,3 - 5,5	3,2	22	36	8°			LI25M43PB3	F03FS02673
	200	4,3 - 5,5	3,2	30	36	8°	2/9/60 + 2/10/60	Scheer	LI25M43PC3	F03FS02674
	200	4,3 - 5,5	3,2	45	36	8°		Holzma, Hyundai Sangi	LI25M43PE3	F03FS02676
	200	4,3 - 5,5	3,2	50	36	8°	2/7/80 + 3/13/80	Giben, KDT	LI25M43PF3	F03FS02679
	200	4,3 - 5,5	3,2	65	36	8°	2/9/100 + 2/9/110	Selco	LI25M43PI3	F03FS02681
	200	4,3 - 5,5	3,2	80	36	8°	2/14/110	Gabbiani	LI25M43PL3	F03FS02683
<b>novo</b>	200	4,3 - 5,5	3,2	75	36	8°		Hyundai Sangi	LI25M43PT3	F03FS07755
	200	4,5 - 5,7	3,0	22	36	8°			LI25M45PB3	F03FS02712
	200	4,5 - 5,7	3,0	65	36	8°	2/8,5/110	Selco	LI25M45PI3	F03FS02714
	200	4,7 - 5,9	3,5	20	36	8°	2/11/66		LI25M47PA3	F03FS02716
	200	4,7 - 5,9	3,5	22	36	8°			LI25M47PB3	F03FS02717
	200	4,7 - 5,9	3,5	30	36	8°	2/9/60	Scheer	LI25M47PC3	F03FS02718
	200	4,7 - 5,9	3,5	45	36	8°		Holzma	LI25M47PE3	F03FS02719
	200	4,7 - 5,9	3,5	65	36	8°	2/9/100 + 2/9/110	Selco	LI25M47PI3	F03FS02720
	200	5,4 - 6,6	3,8	20	36	8°			LI25M54PA3	F03FS02726
	200	5,7 - 6,9	4,0	45	36	8°		Holzma	LI25M57PE3	F03FS02728
<b>novo</b>	200	5,7 - 6,9	3,5	65	36	8°	2/9/110		LI25M57PI3BS*	F03FS08165
	200	6,1 - 7,3	4,2	20	36	8°	2/11/66	Schelling, Scheer	LI25M61PA3	F03FS02730
	215	4,3 - 5,5	3,2	50	42	8°	2/7/80 + 3/15/80	Giben	LI25M43QF3	F03FS02685
	215	4,5 - 5,7	3,2	50	42	8°	3/15/80	Giben	LI25M45PF3	F03FS02713
	220	6,3 - 7,5	4,4	20	36	8°	2/11/66	Schelling	LI25M63UA3	F03FS02732
<b>novo</b>	250	3,1 - 4,3	2,2	30	54	8°			LI25M310C3	F03FS07595
	250	4,3 - 5,5	3,2	50	48	8°	3/13/80	Giben	LI25M430F3	F03FS02669
	250	4,3 - 5,5	3,2	30	48	8°	2/10/60		LI25M430C3	F03FS02668
	280	4,3 - 5,5	3,2	30	48	6°	2/10/60	Panhans	LI25M43VC3	F03FS07419
	300	4,3 - 5,5	3,0	65	48	6°	2/9/100 + 2/9/110	Selco	LI25M43RX3	F03FS07616
	300	4,3 - 5,5	3,2	30	48	6°	2/11/75 + 2/13/94	Schelling	LI25M43RC3	F03FS07577
	300	4,3 - 5,5	3,5	50	48	12°	3/15/80	Giben	LI25M43RM3	F03FS02693
	300	4,3 - 5,5	3,2	65	72	12°	2/9/110	Selco	LI25M43RI3	F03FS02689
	300	4,3 - 5,5	3,2	80	72	12°	2/14/110		LI25M43RL3	F03FS02691
	300	4,7 - 5,9	3,5	65	48	6°	2/9/110	Selco	LI25M47RX3	F03FS07744
	320	4,3 - 5,5	3,0	45	48	12°			LI25M43SE3	F03FS02696
	320	4,3 - 5,5	3,2	45	48	12°			LI25M43SA3	F03FS02695
	340	4,7 - 5,9	3,5	45	72	12°	3/14/65	Holzma	LI25M47TE3	F03FS02722

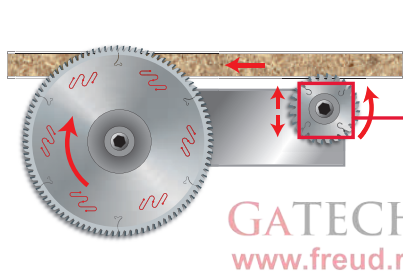

A= Cutting kerf of main saw blade.  
B= Cutting kerf of the conical scorer, which can be adjusted vertically.  
A= Širina reza glavne testere.  
B= Širina reza konusnog predrezača, koja se može vertikalno podešavati.

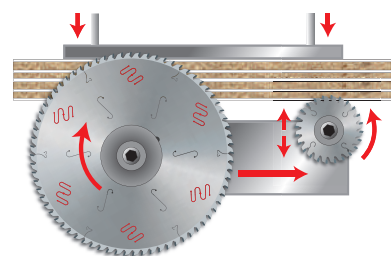
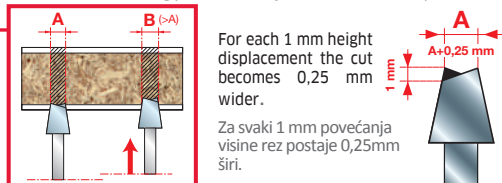

# LI16M

## HW - Adjustable scoring saw blades TM - Podesivi predrezači

To score the coating on bilaminated panels.

**Machines:** Horizontal panel sizing machines that do not allow the adjustment of the scoring depth. Max scoring depth 2 mm.

**Features:** ATB tooth 5° with positive cutting angle.

**Material:** Bilaminated chipboard or MDF.

Za prosecanje folije na obostrano oplemenjenim pločastim materijalima.

**Mašine:** Horizontalni formatizeri bez podešavanja dubine prosecanja.

Maksimalna dubina prosecanja je 2mm.

**Oblik zuba:** ATB 5° sa pozitivnim uglom rezanja.

**Materijal:** Dvostruko oplemenjena iverica ili MDF (medijapan).

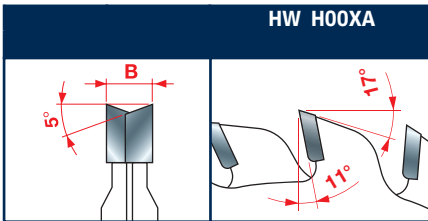

Tooth features - Karakteristike zuba

D mm	B mm	d mm	Z	Machines Mašine	Code Šifra	SAP SAP
80	2,8-3,6	20	10+10	Robland	<b>LI16M HA3</b>	F03FS02502
80	2,8-3,6	20	12+12	Felder	<b>LI16M GA3</b>	F03FS02501
100	2,8-3,6	20	12+12	Schelling - Panhans - Martin	<b>LI16M BA3</b>	F03FS02491
100	2,8-3,6	22	12+12	Altendorf - Striebig - Panhans	<b>LI16M BB3</b>	F03FS02493
100	2,8-3,6	25,4	12+12	Baldan	<b>LI16M BR3</b>	F03FS07433
105	2,8-3,6	20	10+10		<b>LI16M CA3</b>	F03FS02495
120	2,8-3,6	20	12+12	Holzher - SCM	<b>LI16M AA3</b>	F03FS02485
120	2,8-3,6	22	12+12	Altendorf - Martin - Mrozek	<b>LI16M AB3</b>	F03FS02488
120	2,8-3,6	50	12+12	Altendorf - Griggio	<b>LI16M PF3*</b>	F03FS02512
120	2,8-3,6	50	12+12	Felder	<b>LI16M RF3*</b>	F03FS06512
120	4,0-5,0	50	12+12		<b>LI16M IF3*</b>	F03FS02504
125	2,8-3,6	20	12+12	Paoloni	<b>LI16M FA3</b>	F03FS02500
125	2,8-3,6	20	14+14		<b>LI16M EA3</b>	F03FS02498
125	2,8-3,6	22	14+14		<b>LI16M EB3</b>	F03FS02499
125	4,0-4,7	20	20+20	SCM	<b>LI16M DA3</b>	F03FS02496
125	4,0-5,0	45	12+12	Giben - Mayer	<b>LI16M KE3</b>	F03FS02506
200	4,0-5,2	50	28+28	Giben	<b>LI16M OF3</b>	F03FS02511

\* Thickness adjustment controlled by the machines, no spacers required.

\* Podešavanje širine se mašinski kontrolirše, nisu potrebni distanceri.

**GATECH**  
www.freud.rs

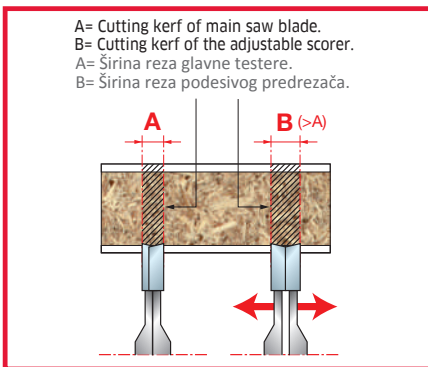

# LI27M

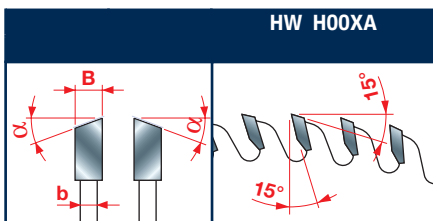

Tooth features - Karakteristike zuba

# LI20M

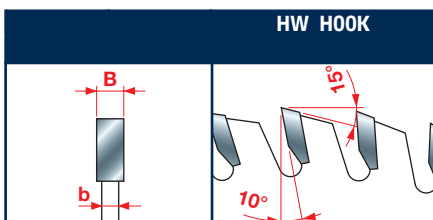

Tooth features - Karakteristike zuba

## HW - Postforming scoring saw blades TM - Predrezači za radne ploče

To score the coating on bilaminated panels.

**Machines:** Horizontal panel sizing machines.

**Features:** ATB tooth with positive cutting angle.

**Material:** Bilaminated chipboard or MDF.

Za prosecanje folije na obostrano oplemenjenim pločastim materijalima.

**Mašine:** Horizontalni formatizeri.

**Oblik zuba:** ATB sa pozitivnim uglom rezanja.

**Materijal:** Obostrano oplemenjena iverica ili MDF (medijapan).

D mm	B mm	b mm	d mm	Z	$\alpha$	NL Pomoćni otvori	Code Šifra	SAP SAP
200	4,7	3,5	80	42	10°	2/14/110	LI27M FA3	F03FS02749
220	3,4	2,2	30	48	10°		LI27M AA3	F03FS02733
250	4,6	3,0	30	48	10°		LI27M BA3	F03FS02734
280	4,7	3,2	80	72	15°	2/14/110	LI27M47VL3	F03FS08014
280	5,0	3,5	45	84	30°		LI27M CA3	F03FS02736
300	4,5	3,0	75	72	10°		LI27M DE3	F03FS02744
300	4,55	3,0	30	72	10°		LI27M DF3	F03FS02745
300	4,55	3,2	65	72	10°	2/9/100+2/9/110	LI27M DA3	F03FS02737
300	4,55	3,2	50	72	10°	3/15/80	LI27M DD3	F03FS02743
300	4,7	3,2	80	72	10°	2/14/110	LI27M DC3	F03FS02741
300	4,95	3,0	65	72	10°	2/9/100+2/9/110	LI27M DB3	F03FS02739
340	5,0	3,5	45	48	30°	3/14/65	LI27M EA3	F03FS02746
340	5,0	3,5	45	108	30°	3/14/65	LI27M EB3	F03FS02747

GATECH  
www.freud.rs

## HW - Flat tooth scoring saw blades TM - Predrezači sa ravnim zubom

To score bilaminated panels with plastic coating.

**Machines:** Horizontal panel sizing machines.

**Features:** Flat tooth with positive cutting angle.

**Material:** Bilaminated chipboard or MDF.

Za prosecanje folije od plastičnih polimera na obostrano oplemenjenim pločastim materijalima.

**Mašine:** Horizontalni formatizeri.

**Oblik zuba:** Ravan zub sa pozitivnim uglom rezanja.

**Materijal:** Obostrano oplemenjena iverica ili MDF (medijapan).

D mm	B mm	b mm	d mm	Z	NL Pomoćni otvori	Code Šifra	SAP SAP
180	3,2	2,2	50	54	3/22/80	LI20M BB3	F03FS02579

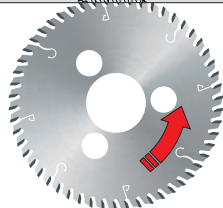
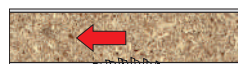



# LI17M



## HW HOOK

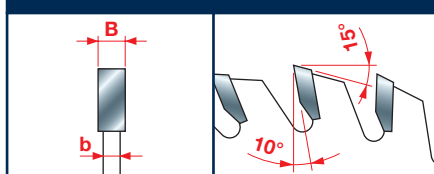

Tooth features - Karakteristike zuba

## HW - Flat tooth scoring saw blades TM - Predrezači sa ravnim zubom

To score the coating on bilaminated panels.

**Machines:** SCM Horizontal panel sizing machines.

**Features:** Flat tooth with positive cutting angle.

**Material:** Bilaminated chipboard or MDF.

Za prosecanje folije na obostrano oplemenjenim pločastim materijalima.

**Mašine:** SCM horizontalni formatizeri.

**Oblik zuba:** Ravan sa pozitivnim uglom rezanja.

**Materijal:** Obostrano oplemenjena iverica ili medijapan (MDF).

D mm	B mm	b mm	d mm	Z	NL Pomoćni otvori	Code Šifra	SAP SAP
115	3,2	2,2	20	30		LI17M FA3	F03FS02572
120	3,2	2,2	20	30		LI17M GA3	F03FS02574

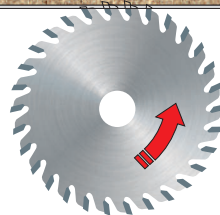

GATECH  
www.freud.rs

# LI22MD - LI22MS

Right  
Desni

Left  
Levi



Left  
Levi

Right  
Desni

## HW HOOK

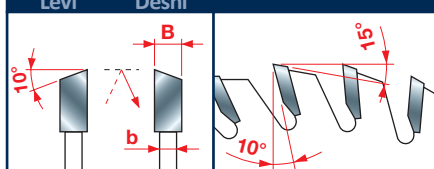

Tooth features - Karakteristike zuba

## HW - Inclined tooth scoring saw blades TM - Predrezači sa kosim zubom

To score bilaminated panels with plastic or thermohardened resins coating.

**Machines:** Horizontal panel sizing machines.

**Features:** Inclined tooth with positive cutting angle.

**Material:** Bilaminated chipboard or MDF.

Za prosecanje obostrano oplemenjenih pločastih materijala sa tvrdom folijom.

**Mašine:** Horizontalni formatizeri.

**Oblik zuba:** Kosi sa pozitivnim uglom rezanja.

**Materijal:** Obostrano oplemenjena iverica ili medijapan (MDF).

D mm	B mm	b mm	d mm	Z	NL Pomoćni otvori	Code Šifra	SAP SAP	Code Šifra	SAP SAP
						D - Desni	D - Desni	S - Levi	S - Levi
150	3,2	2,2	30	36		LI22MD KC3	F03FS02581	LI22MS KC3	F03FS02592
150	3,2	2,2	55	36		LI22MD KG3	F03FS02583	LI22MS KG3	F03FS02594
150	3,2	2,2	60	36		LI22MD KH3	F03FS02584	LI22MS KH3	F03FS02595
180	3,2	2,2	30	42		LI22MD NC3	F03FS02585	LI22MS NC3	F03FS02596
180	3,2	2,2	55	42		LI22MD NG3	F03FS02586	LI22MS NG3	F03FS02598
200	3,2	2,2	30	48		LI22MD PC3	F03FS02589	LI22MS PC3	F03FS02601
200	3,2	2,2	60	48		LI22MD PH3	F03FS02590	LI22MS PH3	F03FS02602



# LI13MD - LI13MS

Right  
Desni

Left  
Levi

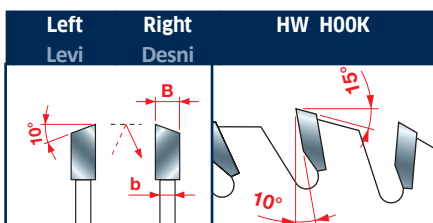

Tooth features - Karakteristike zuba

# LI14MD - LI14MS

Right  
Desna

Left  
Leva

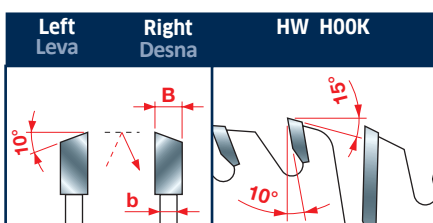

Tooth features - Karakteristike zuba

## HW - Inclined tooth scoring saw blades TM - Predrezači sa kosim zubom

To score bilaminated panels with very fragile plastic coating.

**Machines:** Panel sizing machines, double-end tenoners, edge banders.

**Features:** Inclined tooth with positive cutting angle.

**Material:** Bilaminated chipboard or MDF.

Za prosecanje obostrano oplemenjenih pločastih materijala sa veoma osetljivom plastičnom folijom.

**Mašine:** Formatizeri, dvostrani formatizeri, kanterice.

**Oblik zuba:** Kosi sa pozitivnim uglom rezanja.

**Materijal:** Obostrano oplemenjena iverica i medijapan (MDF).

D mm	B mm	b mm	d mm	Z	NL FT	Code Šifra D - Desni	SAP SAP D - Desni	Code Šifra S - Levi	SAP SAP S - Levi
100	3,2	2,2	20	24		LI13MD AA3	F03FS02452	LI13MS AA3	F03FS02466
100	3,2	2,2	22	24		LI13MD AB3	F03FS02454	LI13MS AB3	F03FS02468
125	3,2	2,2	20	30		LI13MD BA3	F03FS02455	LI13MS BA3	F03FS02470
150	3,2	2,2	30	48		LI13MD DA3	F03FS02459	LI13MS DA3	F03FS02474
150	3,2	2,2	55	48		LI13MD DB3	F03FS02461	LI13MS DB3	F03FS02476

GATECH  
www.freud.rs

## HW - End trim unit for panels with banded edges TM - Testera za odsecanje kant trake

For cutting and boarding panels with banded edges.

**Machines:** Edge banders.

**Features:** Inclined toothing with 4 oversized teeth with positive cutting angle.

**Material:** Bilaminated chipboard or MDF.

Za materijale sa kant trakom.

**Mašine:** Kanterice.

**Oblik zuba:** Kosi, sa 4 čistača i pozitivnim uglom rezanja.

**Materijali:** Obostrano oplemenjena iverica ili medijapan (MDF).

D mm	B mm	b mm	d mm	Z	NL FT	Code Šifra D - Desna	SAP SAP D - Desna	Code Šifra S - Leva	SAP SAP S - Leva
140	3,2	2,2	30	28+4		LI14MD CA3	F03FS02481	LI14MS CA3	F03FS02483

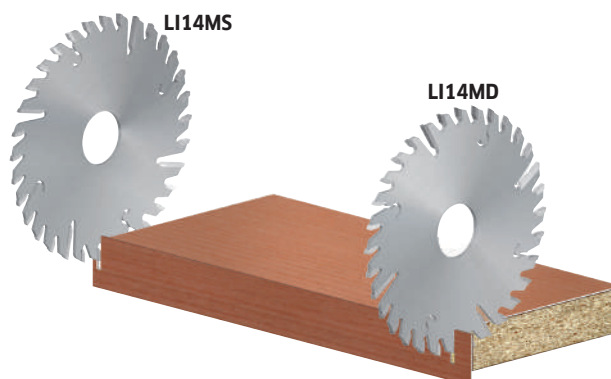

# LT16MD - LT16MS

Right  
Desna

Left  
Leva

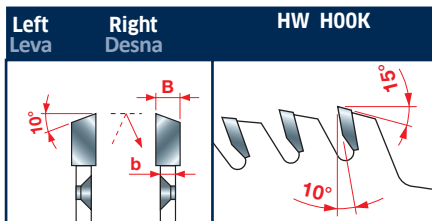

Tooth features - Karakteristike zuba

# LT12MD - LT12MS

Right  
Desna

Left  
Leva

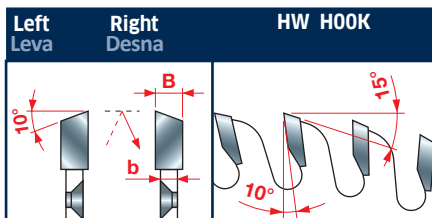

Tooth features - Karakteristike zuba

## HW - Saw blades for freud hogging units TM - Testere za FREUD drobljače

Saw blades suitable for squaring and trimming panels.

**Machines:** Single-side or double-end tenoners and squaring edgebanding machines.

**Features:** Right or left inclined tooth with positive cutting angle.

**Material:** Bilaminated panels.

Testere za drobljenje prilikom formatiranja pločastih materijala.

**Mašine:** Jednostrani/dvostrani formatizeri i kanterice sa opcijom formatiranja.

**Oblik zuba:** Desno ili levo iskošen sa pozitivnim uglom rezanja.

**Materijal:** Obostrano oplemenjeni pločasti materijali.

D	B	b	d	Z	NL	Code	SAP	Code	SAP
mm	mm	mm	mm		FT	D - Desna	D - Desna	S - Leva	S - Leva
250	4,2	3,0	130	56	10/8,5/170	LT16MD BD3	F03FS04401	LT16MS BD3	F03FS04409
300	4,2	3,0	130	68	10/8,5/215	LT16MD CD3	F03FS04404	LT16MS CD3	F03FS04412

GATECH  
www.freud.rs

## HW - Saw blades for hogging units TM - Testere za drobljače

Saw blades suitable for squaring and trimming panels.

**Machines:** Single-side or double-end tenoners and squaring edgebanding machines.

**Features:** Right or left inclined tooth with positive cutting angle.

**Material:** Bilaminated panels.

Testere za drobljenje prilikom formatiranja pločastih materijala.

**Mašine:** Jednostrani/dvostrani formatizeri i kanterice sa opcijom formatiranja.

**Oblik zuba:** Desno ili levo iskošen sa pozitivnim uglom rezanja.

**Materijal:** Obostrano oplemenjeni pločasti materijali.

D	B	b	d	Z	NL	Code	SAP	Code	SAP
mm	mm	mm	mm		FT	Codice	SAP	Codice	SAP
						D - Desni	D - Desni	S - Levi	S - Levi
250	4,2	3,0	130	60	4/8,5/185	LT12MD BB3	F03FS04372	LT12MS BB3	F03FS07063

# LT14MD - LT14MS

Right  
Desna

Left  
Leva

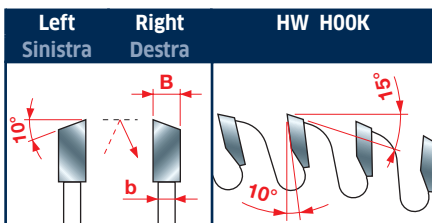
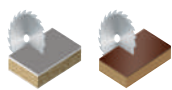

Tooth features - Karakteristike zuba

# LT18MD - LT18MS

Right  
Desna

Left  
Leva

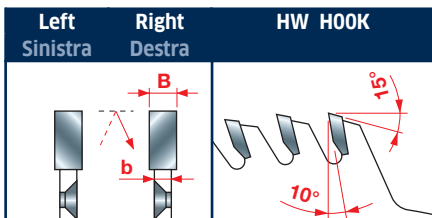
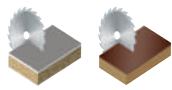
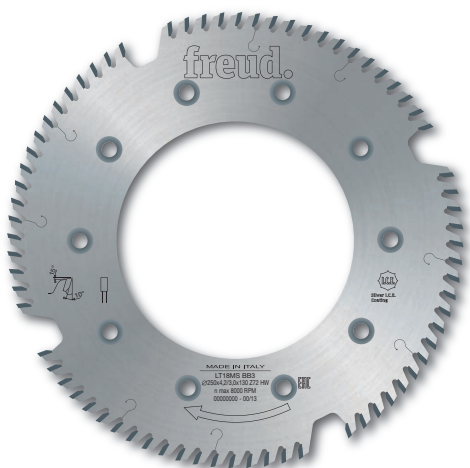

Tooth features - Karakteristike zuba

## HW - Saw blades for hogging units (customized) TM - Testere za drobljače (specijalne izvedbe)

Saw blades suitable for squaring and trimming panels.

**Machines:** Single-side or double-end tenoners and squaring edgebanding machines.

**Features:** Right or left inclined tooth with positive cutting angle.

**Material:** Bilaminated panels.

Testere za drobljenje prilikom formatiranja pločastih materijala.

**Mašine:** Jednostrani/dvostrani formatizeri i kanterice sa opcijom formatiranja.

**Oblik zuba:** Desno ili levo iskošen sa pozitivnim uglom rezanja.

**Materijal:** Obostrano oplemenjeni pločasti materijali.

D	B	b	d	Z	NL	Code	SAP	Code	SAP
mm	mm	mm	mm		FT	Šifra	SAP	Šifra	SAP
						D - Desna	D - Desna	S - Leva	S - Leva
200	4,2	3,0	30	48	*	LT14MD AA3	F03FS04378	LT14MS AA3	F03FS04389
250	4,2	3,0	30	60	*	LT14MD BA3	F03FS04380	LT14MS BA3	F03FS04391
250	4,2	3,0	130	60	*	LT14MD BB3	F03FS04382	LT14MS BB3	F03FS04393
255	4,2	3,0	80	60	*	LT14MD FA3	F03FS04387	LT14MS FA3	F03FS04398
350	4,2	3,0	30	84	*	LT14MD DA3	F03FS04386	LT14MS DA3	F03FS04397

### \* WHEN ORDERING, ALWAYS SPECIFY:

a) **OPT08 AA9:** for increasing bore Ø;

b) **OPTFO...:** for pin holes (NL\* - see page 92).

**Send sample saw blade or drawing with bore size, PCD and hole size (ex. OPTFO AF9 with 6 countersunk holes).**

### \* KADA VRŠITE PORUDŽBINU, UVEK NAGLASITE:

a) **OPT08 AA9:** za povećanje dijametra otvora;

b) **OPTFO...:** za pomoćne otvore (FT\* - vidi stranicu 92).

**Pošaljite uzorak ili crtež sa odgovarajućom veličinom otvora i pomoćnih rupa (npr. OPTFO AF9 sa 6 otvora).**

## HW - Saw blades for freud hogging units TM - Testere za FREUD drobljače

Saw blades suitable for squaring and trimming panels.

**Machines:** Single-side or double-end tenoners and squaring edgebanding machines.

**Features:** Flat tooth with positive cutting angle.

**Material:** Bilaminated panels.

Testere za drobljenje prilikom formatiranja pločastih materijala.

**Mašine:** Jednostrani/dvostrani formatizeri i kanterice sa opcijom formatiranja.

**Oblik zuba:** Ravan sa pozitivnim uglom rezanja.

**Materijal:** Obostrano oplemenjeni pločasti materijali.

D	B	b	d	Z	NL	Code	SAP	Code	SAP
mm	mm	mm	mm		FT	Šifra	SAP	Šifra	SAP
						D - Desna	D - Desna	S - Leva	S - Leva
250	4,2	3,0	130	72	10/8,5/170	LT18MD BB3	F03FS04415	LT18MS BB3	F03FS04417

GATECH  
www.freud.rs

# LT20MD - LT20MS

Right  
Desna

Left  
Leva



## HW - Saw blades for Leuco hogging units TM - Testere za LEUCO drobljače

Saw blades suitable for squaring and trimming panels.

**Machines:** Single-side or double-end tenoners and squaring edgbanding machines.

**Features:** Flat tooth with positive cutting angle.

**Material:** Bilaminated panels.

Testere za drobljenje prilikom formatiranja pločastih materijala.

**Mašine:** Jednostrani/dvostrani formatizeri i kanterice sa opcijom formatiranja.

**Oblik zuba:** Ravan sa pozitivnim uglom rezanja.

**Materijal:** Obostrano oplemenjeni pločasti materijali.

D	B	b	d	Z	NL	Code	SAP	Code	SAP
mm	mm	mm	mm		FT	Šifra	SAP	Šifra	SAP
						D - Desna	D - Desna	S - Leva	S - Leva
250	4,0	3,0	100	72	6/7/200	LT20MD BB3	F03FS04421	LT20MS BB3	F03FS04422

GATECH  
[www.freud.rs](http://www.freud.rs)

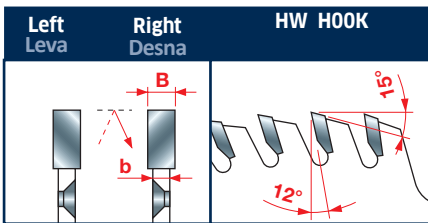
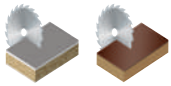

Tooth features - Karakteristike zuba

# TR16MD - TR16MS

Right  
Desni

Left  
Levi

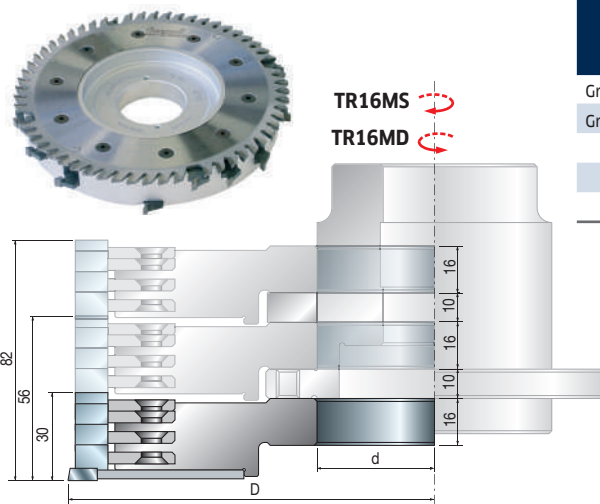
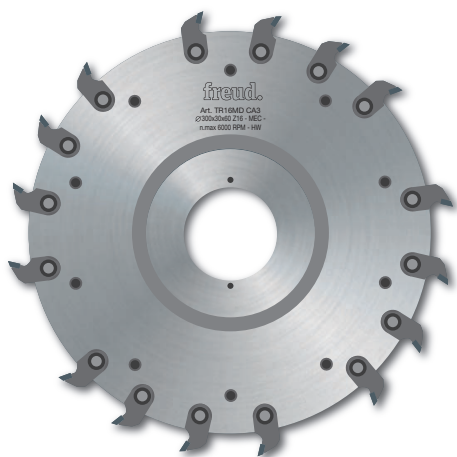

## Hogging units with SR06M interchangeable inserts Drobljači sa SR06M izmenjivim pločicama

Particularly indicated for squaring solid wood panels.

**Machines:** Single-side or double-end tenoners.

**Features:**

- Spare saw blades: LT16MD/S - LT18MDS.

- Supplied with resharpenable inserts fitted with 2 spiral disposition.
- Excellent chipping.
- Easy feed rate.

Idealni za formatiranje tabli od masiva.

**Mašine:** Jednostrani/dvostrani formatizeri.

**Karakteristike:** Rezervne izmenjive pločice LT16MD/S - LT18MD/S

- Snabdeveni izmenjivim pločicama koje mogu da se oštire, pričvršćivanje sa 2 spiralna šrafa.
- Odlično drobljenje.
- Lako dodavanje komada.

\* Nominal saw blade diameter. / \* Nominalni prečnik testere.

D	B	b	d	Code	SAP	Code	SAP
mm	mm	mm	mm	Šifra	SAP	Šifra	SAP
				D - Desni	D - Desni	S - Levi	S - Levi
200	30	80	16	<b>TR16MD AA3</b>	F03FC20547	<b>TR16MS AA3</b>	F03FC20550
250	30	60	16	<b>TR16MD BA3</b>	F03FC20548	<b>TR16MS BA3</b>	F03FC20551
250	30	80	16	<b>TR16MD BB3</b>	F03FC22094	<b>TR16MS BB3</b>	F03FC22096
300	30	60	16	<b>TR16MD CA3</b>	F03FC20549	<b>TR16MS CA3</b>	F03FC20552
300	30	80	16	<b>TR16MD CB3</b>	F03FC22095	<b>TR16MS CB3</b>	F03FC22097

Spare parts	Dimensions	Code	SAP
Rezervni delovi	Dimenzije	Šifra	SAP
Grooving inserts / izmenjive pločice	34 x 9 x 16	<b>SR06MDBB301</b>	F03FC24198
Grooving inserts / izmenjive pločice	34 x 9 x 16	<b>SR06MSBB301</b>	F03FC24201
Screw / Šraf	M6 x 11, 5	<b>VT16M AB9</b>	F03FA04477
Screw / Šraf	M6 x 10	<b>VT01M AA9</b>	F03FA04429
Allen key / Ključ	4 x 110	<b>CB03M BA9</b>	F03FA00163

These tools can be stacked and used in multiples thus enabling the machining of a wider area.

Ovi alati se mogu kombinovati i koristiti kao višelisna opcija, omogućujući obrađivanje šireg područja.

**GATECH**  
www.freud.rs

# MT01M

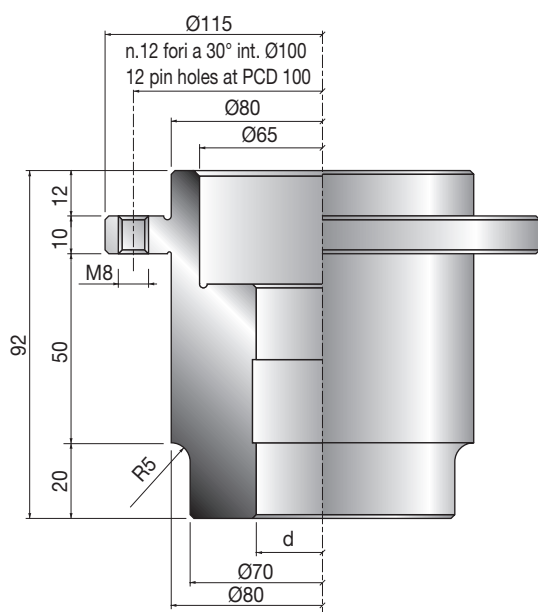

## Mounting sleeves for hogging units Dodatni držači za drobljače

Item MT01M includes the fixing operation of the mounting sleeve to the hogging unit.

**Note: The fixing must be done in our factory and only on freud's hoggers. This mounting sleeve works only with the hogging units item TR16M and must be ordered separately.**

Držač MT01M ima mogućnost fiksiranja za drobljač.

**Napomena: Fiksiranje se mora uraditi u našoj fabrici i moguće je samo za FREUD drobljače. Ovaj deo može se dodati isključivo na FREUD drobljače TR16M i naručuje se posebno.**

d	KN	Code	SAP
mm	CH	Šifra	SAP
35	10 x 4	<b>MT01M DA9</b>	F03FC15424



# LU4A

## HW - Saw blades to cut plastic materials TM - Testere za rezanje plastičnih materijala

Blades with negative cutting angle that is suitable to cut plastic materials. In order to cut in a correct way, the saw blade has to stick out approximately 30 mm over the material to be cut.

**Machines:** Circular saws, portable machines.

**Features:** Flat-triple chip tooth with negative cutting angle. The specific size of the teeth allows cutting with perfect finishing, without melting and scratching the material.

**Material:** Plastic materials, plexiglas.

Testere sa negativnim zubom koji je pogodan za rezanje plastičnih materijala. Da bi se rezanje odradilo kako treba, testera mora da viri barem oko 30mm iz materijala koji se reže.

**Mašine:** Stabilni cirkulari, ručni cirkulari.

**Oblik zuba:** Naizmenično ravni i trapezni sa negativnim uglom rezanja. Specifična veličina zuba omogućava savršen završni rez, bez topljenja i grebanja materijala.

**Materijal:** Plastični materijali, pleksiglas.

**FT01:** 2/7/42 + 2/9/46,4 + 2/10/60

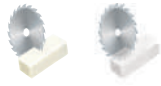

D mm	B mm	b mm	d mm	Z	NL Pomoćni otvori	Code Šifra	SAP SAP
250	2,8	2,2	30	80	FT01	<b>LU4A 0100</b>	F03FS05163
300	2,8	2,2	30	96	FT01	<b>LU4A 0200</b>	F03FS05165

**GATECH**  
[www.freud.rs](http://www.freud.rs)

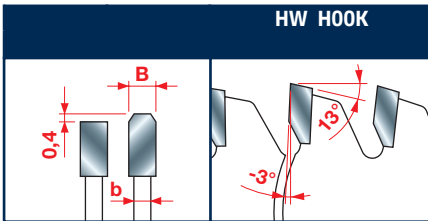

Tooth features - Karakteristike zuba

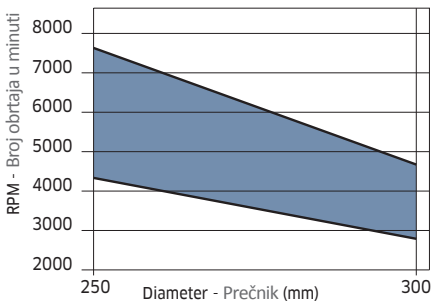

Minimum and maximum RPM based on the blade diameter.

Minimalan i maksimalan broj obrtaja u odnosu na prečnik testere.

	Ultimate Najbolja	High Odlična	Good Dobra
Plexiglas Pleksiglas	●		
Plastic materials Plastični materijali	●		

# LU4B

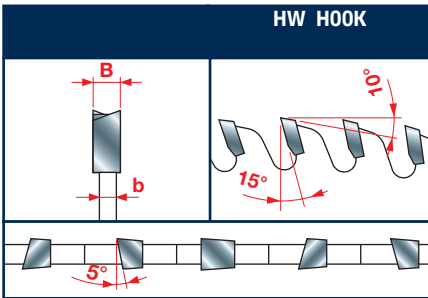
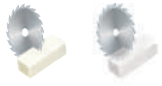
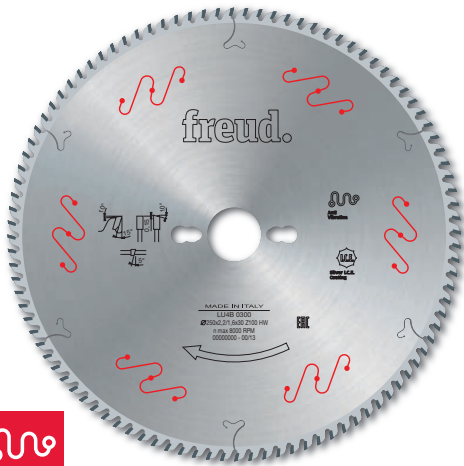

Tooth features - Karakteristike zuba

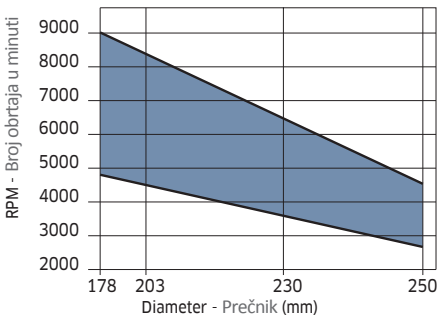

Minimum and maximum RPM based on the blade diameter.  
Minimalan i maksimalan broj obrtaja u odnosu na prečnik testere.

## HW - Saw blades to cut plastic materials and plexiglas - thin kerf TM - Testere za rezanje plastičnih materijala i pleksiglasa - tanak rez

To size plexiglas and plastic material panels. The reduced cutting height makes workpiece feeding easier and optimises its employment in low-power machines.

**Machines:** Circular saws, portable machines.

**Features:** Flat-ATB 10° tooth with 5° shear angle and positive cutting angle. The specific shape of the tooth ensures an excellent finishing and cutting life.

**Material:** Plastic materials, plexiglas.

Testere sa za rezanje pleksiglasa i tabli od plastičnih materijala. Smanjena debljina tela omogućava lakše ubacivanje komada i optimizuje rezanje kod mašina slabije snage.

**Mašine:** Stabilni cirkulari, ručni cirkulari.

**Oblik zuba:** Naizmenično ravni i ATB 10° sa grudnim uglom od 5° i pozitivnim uglom rezanja. Specifičan oblik zuba omogućava odličan završni rez i dug radni vek.

**Materijal:** Plastični materijali, pleksiglas.

**FT01:** 2/7/42 + 2/9/46,4 + 2/10/60

D mm	B mm	b mm	d mm	Z	NL Pomoćni otvori	Code Šifra	SAP SAP
178	1,5	1,0	25,4	80		LU4B 0500	F03FS05173
203	2,0	1,4	25,4	90		LU4B 0100	F03FS05167
230	2,2	1,6	25,4	100		LU4B 0200	F03FS05169
250	2,2	1,6	30	100	FT01	LU4B 0300	F03FS05170
255	2,2	1,6	25,4	100		LU4B 0400	F03FS05172

GATECH  
www.freud.rs

	Ultimate Najbolja	High Odlična	Good Dobra
Plexiglas Pleksiglas	●		
Plastic materials Plastični materijali	●		

# LU4D

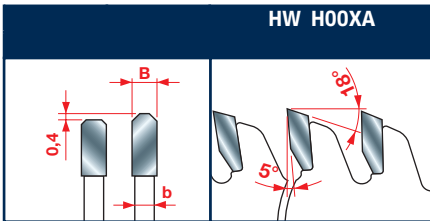
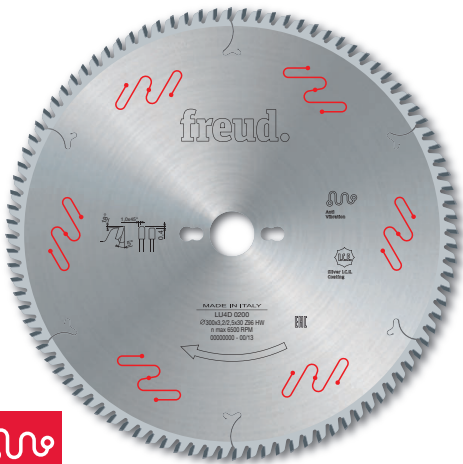

Tooth features - Karakteristike zuba

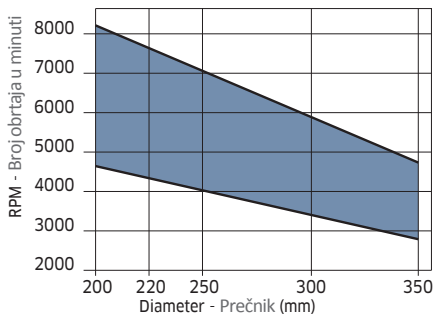

Minimum and maximum RPM based on the blade diameter.  
Minimalan i maksimalan broj obrtaja u odnosu na prečnik testere.

## HW - Saw blades to cut solid surfaces TM - Testere za rezanje radnih ploča

Saw blades optimized to cut solid surfaces boards.

**Machines:** Sliding table saws, miter saws.

**Features:** The special double triple chip tip grind and the thickness of the plate allow to get the best quality of cut in solid surfaces application. Moreover, they guarantee a longer lifetime versus standard products, despite the highly abrasive material.

**Material:** Solid surfaces, Corian boards and similar materials.

Testere dizajnirane za rezanje radnih ploča (Korijan...).

**Mašine:** Stabilni cirkulari sa kliznim stolom, gerovi.

**Oblik zuba:** Specijalni trapezni zubi sa dvostrukim i trostrukim ivicama i debljina ploče omogućavaju najbolji mogući kvalitet reza na tržištu kada su u pitanju radne ploče. Ove karakteristike garantuju i znatno duži radni vek od standardnih, uprkos velikoj poroznosti materijala.

**Materijal:** Radne ploče, Korijan table i slični materijali.

D	B	b	d	Z	NL	Code	SAP
mm	mm	mm	mm		Pomoćni otvori	Šifra	SAP
250	3,2	2,5	30	80	FT02	LU4D 0100	F03FS07294
300	3,2	2,5	30	96	FT02	LU4D 0200	F03FS07295
350	3,5	2,80	30	108	FT02	LU4D 0300	F03FS07296

GATECH  
www.freud.rs

Ultimate	High	Good
Najbolja	Odlična	Dobra

Solid surfaces  
Radne ploče



# LU5A

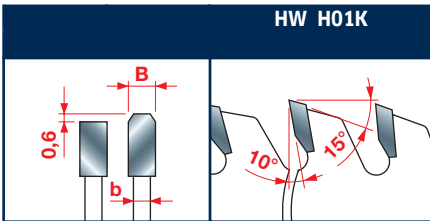
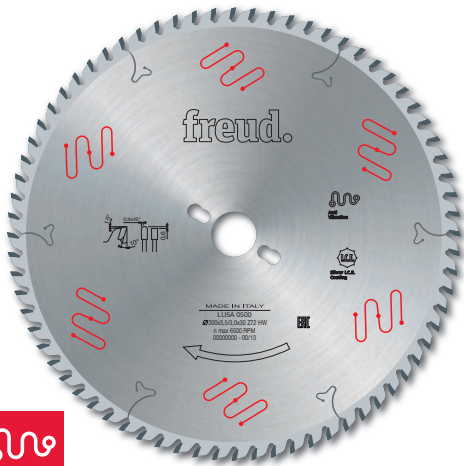

Tooth features - Karakteristike zuba

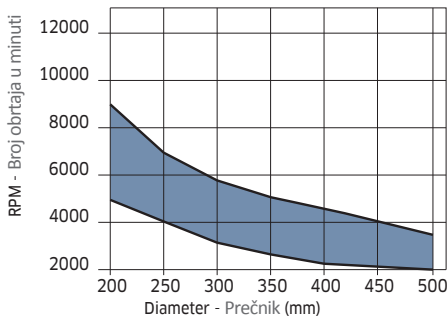

Minimum and maximum RPM based on the blade diameter.

Minimalan i maksimalan broj obrtaja u odnosu na prečnik testere.

## HW - Saw blades to cut non-ferrous metals TM - Testere za rezanje aluminijuma (obojenih metala)

To cut solid drawn products with a thickness between 2 and 10 mm.

**Machines:** Single or double miter saws with mechanical clamping of the piece.

**Features:** Flat-triple chip tooth with positive cutting angle.

**Material:** Aluminum and non-ferrous metals.

Testere za rezanje punih materijala debljine od 2 do 10mm.

**Mašine:** Običan ili dupli ger sa stezanjem komada.

**Oblik zuba:** Naizmjenično ravni i trapezni sa pozitivnim uglom rezanja.

**Materijal:** Aluminijum i obojeni metali.

**FT02:** 2/9/46,4 + 2/10/60

D mm	B mm	b mm	d mm	Z	NL Pomoćni otvori	Code Šifra	SAP SAP
200	2,8	2,2	30	54		LU5A 0100	F03FS05181
250	3,5	3,0	30	60	FT02	LU5A 0200	F03FS05182
250	3,5	3,0	32	60	2/11/63	LU5A 0300	F03FS05183
275	3,5	3,0	40	68	2/9/55+4/12/64	LU5A 0400	F03FS05185
300	3,5	3,0	30	72	FT02	LU5A 0500	F03FS05186
300	3,5	3,0	32	72	2/11/63	LU5A 0600	F03FS05187
330	3,5	3,0	30	84	FT02	LU5A 0800	F03FS05190
330	3,5	3,0	32	84	2/11/63	LU5A 0900	F03FS05192
350	3,5	3,0	30	84	FT02	LU5A 1000	F03FS05193
350	3,5	3,0	32	84	2/11/63	LU5A 1100	F03FS05194
350	3,5	3,0	40	84	2/9/55+4/12/64	LU5A 1200	F03FS05196
370	3,5	3,0	30	90		LU5A 1300	F03FS05197
370	3,5	3,0	50	90	4/15/80	LU5A 1400	F03FS05198
380	3,5	3,0	32	96	2/11/63	LU5A 1500	F03FS05199
400	3,5	3,0	30	96	2/11/63	LU5A 1600	F03FS05200
400	3,5	3,0	32	96	2/11/63	LU5A 1700	F03FS05202
400	3,5	3,0	40	96	2/12/64+2/15/80	LU5A 1800	F03FS05205
400	3,5	3,0	50	96	4/15/80	LU5A 1900	F03FS05206
420	3,5	3,0	30	96	2/11/70	LU5A 2000	F03FS05207
450	4,0	3,2	30	108	2/11/63	LU5A 2100	F03FS05208
450	4,0	3,2	32	108	2/11/63	LU5A 2200	F03FS05210
450	4,0	3,2	40	108	2/12/64+2/15/80	LU5A 2300	F03FS08047
450	4,0	3,2	50	108	4/15/80	LU5A 2400	F03FS07420
500	4,0	3,2	30	120	2/10,5/70	LU5A 2500	F03FS05212
500	4,0	3,2	32	120	2/11/63	LU5A 2600	F03FS05214
500	4,0	3,2	50	120	4/15/80	LU5A 2700	F03FS08244
<b>novi</b>	500	4,4	3,5	30	120	LU5A 3000	F03FS07543
530	4,2	3,5	30	126	2/10,5/70	LU5A 2800	F03FS06607
550	4,2	3,5	30	132	2/10,5/70	LU5A 2900	F03FS06608

GATECH  
www.freud.rs

Ultimate  
Najbolja

High  
Odlična

Good  
Dobra

Non-ferrous metals  
Aluminijum (obojeni metali)



# LU5B

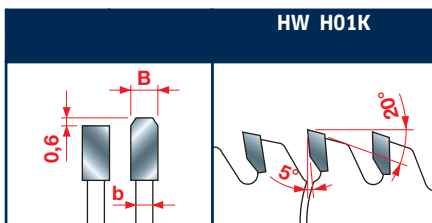
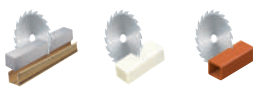
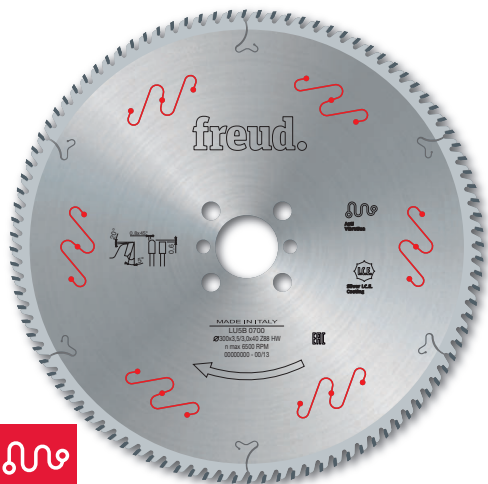

Tooth features - Karakteristike zuba

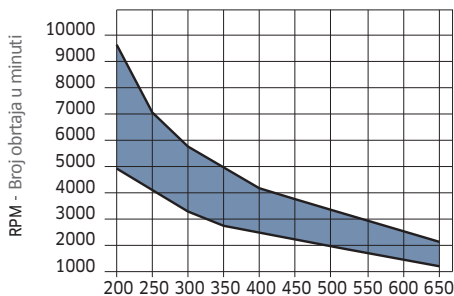

Minimum and maximum RPM based on the blade diameter.  
Minimalan i maksimalan broj obrtaja u odnosu na prečnik testere.

## HW - Saw blades to cut non-ferrous metals and PVC TM - Testere za rezanje aluminijuma (obojenih metala) i PVC-a

To cut drawn products and tubes with a thickness between 2 and 5 mm, as well as polymeric panels up to 20 mm.

**Machines:** Single or double miter saws with mechanical clamping of the piece.

**Features:** Flat-triple chip tooth with positive cutting angle.

**Material:** Aluminum and non-ferrous metals, polymeric materials, PVC extruded profiles.

Testere za rezanje punih materijala i cevi debljine od 2 do 5mm, kao i PVC profila debljine do 20mm.

**Mašine:** Običan ili dupli ger sa stezanjem komada.

**Oblik zuba:** Naizmenično ravni i trapezni sa pozitivnim uglom rezanja.

**Materijal:** Aluminijum i obojeni metali, polimerski materijali, PVC ekstrudirani profili.

**FT02:** 2/9/46,4 + 2/10/60

D mm	B mm	b mm	d mm	Z	NL Pomoćni otvori	Code Šifra	SAP SAP
200	2,8	2,2	30	64		LU5B 0100	F03FS05217
250	3,5	3,0	30	80	FT02	LU5B 0200	F03FS05218
250	3,5	3,0	32	80	2/11/63	LU5B 0300	F03FS05221
275	3,5	3,0	40	84	2/9/55+4/12/64	LU5B 0400	F03FS05223
300	3,5	3,0	30	88	FT02	LU5B 0500	F03FS05224
300	3,5	3,0	32	88	2/11/63	LU5B 0600	F03FS05225
300	3,5	3,0	40	88	2/9/55+4/12/64	LU5B 0700	F03FS05227
300	3,5	3,0	30	96	FT02	LU5B 0800	F03FS05228
300	3,5	3,0	32	96	2/11/63	LU5B 0900	F03FS05230
300	3,5	3,0	40	96	2/9/55+4/12/64	LU5B 1000	F03FS05232
330	3,5	3,0	30	104	FT02	LU5B 1100	F03FS05233
330	3,5	3,0	32	104	2/11/63	LU5B 1200	F03FS05234
350	3,5	3,0	30	96	FT02	LU5B 1300	F03FS05235
350	3,5	3,0	32	96	2/11/63	LU5B 1400	F03FS05236
350	3,5	3,0	40	96	2/9/55+4/12/64	LU5B 1500	F03FS05238
350	3,5	3,0	30	108	FT02	LU5B 1600	F03FS05239
350	3,5	3,0	32	108	2/11/63	LU5B 1700	F03FS05240
350	3,5	3,0	40	108	2/9/55+4/12/64	LU5B 1800	F03FS05242
370	3,5	3,0	30	112		LU5B 1900	F03FS07745
370	3,5	3,0	50	112	4/15/80	LU5B 2000	F03FS05243
380	3,5	3,0	32	112	2/11/63	LU5B 2100	F03FS05244
400	3,5	3,0	30	120	2/11/63	LU5B 2200	F03FS05245
400	3,5	3,0	32	120	2/11/63	LU5B 2300	F03FS05246
400	3,5	3,0	40	120	2/12/64+2/15/80	LU5B 2400	F03FS05248
400	3,5	3,0	50	120	4/15/80	LU5B 2500	F03FS05249
420	3,5	3,0	30	120	2/11/70	LU5B 2600	F03FS05250
450	4,0	3,0	30	128		LU5B 2700	F03FS05251
450	4,0	3,0	32	128	2/11/63	LU5B 2800	F03FS05252
500	4,0	3,2	30	140	2/10,5/70	LU5B 3100	F03FS05254
500	4,0	3,2	32	140	2/11/63	LU5B 3200	F03FS05255
550	4,2	3,5	30	148	2/11/63	LU5B 3500	F03FS05257
550	4,2	3,5	32	148	2/11/63	LU5B 3800	F03FS05260
600	4,8	3,8	30	156		LU5B 3600	F03FS05258

GATECH  
www.freud.rs

	Ultimate Najbolja	High Odlična	Good Dobra
Non-ferrous metals Obojeni metali	●		
Plastic materials Plastični materijali	●		
PVC PVC		●	



# LU5C

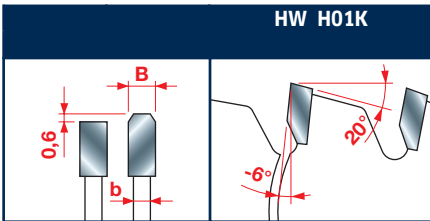

Tooth features - Karakteristike zuba

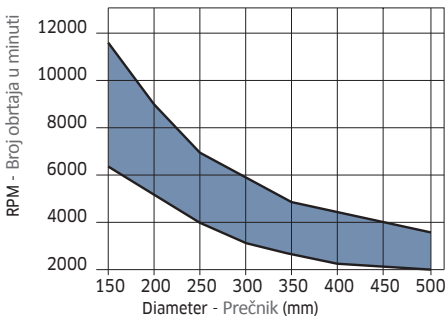

Minimum and maximum RPM based on the blade diameter.

Minimalan i maksimalan broj obrtaja u odnosu na prečnik testere.

## HW - Saw blades to cut non-ferrous metals TM - Testere za rezanje aluminijuma (obojenih metala)

To cut solid drawn products whose thickness exceeds 3 mm. It is recommendable to use it with the saw blade over the workpiece to be cut.

**Machines:** Miter saws with manual or mechanical clamping of the piece.

**Features:** Flat-triple chip tooth with negative cutting angle.

**Material:** Aluminum and non-ferrous metals.

Testere za rezanje materijala čija debljina nije veća od 3mm. Preporučuje se da pri rezanju testera napada materijal sa gornje strane.

**Mašine:** Gerovi sa stezanjem komada.

**Oblik zuba:** Naizmenično ravni i trapezni sa negativnim uglom rezanja.

**Materijal:** Aluminijum i obojeni metali.

**FT01:** 2/7/42 + 2/9/46,4 + 2/10/60

**FT02:** 2/9/46,4 + 2/10/60

D	B	b	d	Z	NL	Code	SAP
mm	mm	mm	mm		Pomoćni otvori	Šifra	SAP
180	2,8	2,2	20	42		LU5C 0100	F03FS07195
180	2,8	2,2	30	42		LU5C 0200	F03FS05261
200	2,8	2,2	30	48		LU5C 0300	F03FS05262
250	3,5	3,0	30	54		LU5C 0400	F03FS05263
275	3,5	3,0	40	60		LU5C 0600	F03FS05264
300	3,5	3,0	30	72	FT02	LU5C 0700	F03FS05265
300	3,5	3,0	32	72	2/11/63	LU5C 0800	F03FS05266
300	3,5	3,0	40	72	2/9/55+4/12/64	LU5C 0900	F03FS05267
330	3,5	3,0	30	80		LU5C 1000	F03FS05268
330	3,5	3,0	32	80	2/11/63	LU5C 1100	F03FS05269
350	3,5	3,0	30	84	FT01	LU5C 1200	F03FS05270
350	3,5	3,0	32	84	2/11/63	LU5C 1300	F03FS05271
350	3,5	3,0	40	84	2/9/55+4/12/64	LU5C 1400	F03FS05272
370	3,5	3,0	30	90		LU5C 1500	F03FS05273
370	3,5	3,0	50	90	4/15/80	LU5C 1600	F03FS05274
380	3,5	3,0	32	96	2/11/63	LU5C 1700	F03FS05275
400	3,5	3,0	30	96	2/11/70	LU5C 1800	F03FS05276
400	3,5	3,0	32	96	2/11/63	LU5C 1900	F03FS05277
400	3,5	3,0	40	96	2/15/80+2/12/64	LU5C 2000	F03FS05278
400	3,5	3,0	50	96	4/15/80	LU5C 2100	F03FS05279
420	4,0	3,2	30	96	2/11/70	LU5C 2200	F03FS05280
420	4,0	3,2	40	96		LU5C 2300	F03FS05281
450	4,0	3,2	30	108		LU5C 2400	F03FS05282
450	4,0	3,2	32	108	2/11/63	LU5C 2500	F03FS05283
450	4,0	3,2	40	108	2/15/80+2/12/64	LU5C 2600	F03FS05284
450	4,0	3,2	50	108	4/15/80	LU5C 2700	F03FS05285
500	4,0	3,2	30	120		LU5C 2800	F03FS06110
500	4,0	3,2	32	120	2/11/63	LU5C 2900	F03FS05286

GATECH  
www.freud.rs

Ultimate Najbolja	High Odlična	Good Dobra
----------------------	-----------------	---------------

Non-ferrous metals  
Aluminijum (obojeni metali)

# LU5D

## HW - Saw blades to cut non-ferrous metals and PVC TM - Testere za rezanje aluminijuma (obojenih metala) i PVC-a

To cut drawn products and tubes whose thickness doesn't exceed 3 mm. It is recommendable to use it with the saw blade over the workpiece to be cut.

**Machines:** Miter saws with manual or mechanical clamping of the piece.

**Features:** Flat-triple chip tooth with negative cutting angle.

**Material:** Aluminum and non-ferrous metals, PVC extruded profiles.

Testere za rezanje punih materijala i profila čija debljina nije veća od 3mm. Preporučuje se da pri rezanju testera napada materijal sa gornje strane.

**Mašine:** Gerovi sa stezanjem komada.

**Oblik zuba:** Naizmenično ravni i trapezni sa negativnim uglom rezanja.

**Materijal:** Aluminijum i obojeni metali, PVC ekstrudirani profili.

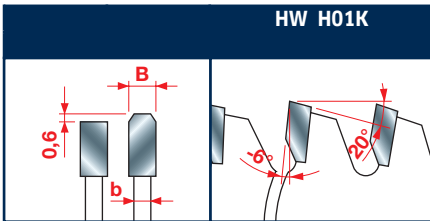
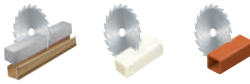

Tooth features - Karakteristike zuba

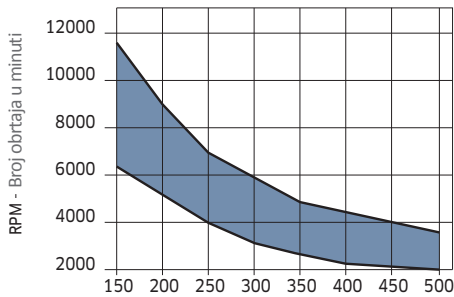

Diameter - Prečnik (mm)

Minimum and maximum RPM based on the blade diameter.

Minimalan i maksimalan broj obrtaja u odnosu na prečnik testere.

FT02: 2/9/46,4 + 2/10/60

D	B	b	d	Z	NL	Code	SAP
mm	mm	mm	mm		Pomoćni otvori	Sifra	SAP
160	2,8	2,2	20	42		LU5D 0100	F03FS05288
190	2,8	2,2	30	54		LU5D 0200	F03FS05289
200	2,8	2,2	30	60		LU5D 0300	F03FS05290
210	2,8	2,2	30	60		LU5D 0400	F03FS05291
216	2,8	2,2	30	60		LU5D 0500	F03FS05292
220	3,0	2,5	30	64	FT02	LU5D 0600	F03FS05293
230	3,0	2,5	30	64		LU5D 0700	F03FS05294
250	3,5	3,0	30	80	FT02	LU5D 0800	F03FS05295
250	3,5	3,0	32	80	2/11/63	LU5D 0900	F03FS05297
250	3,5	3,0	40	80	2/9/55+4/12/64	LU5D 1000	F03FS05299
275	3,5	3,0	40	84	2/9/55+4/12/64	LU5D 1100	F03FS05300
300	3,5	3,0	30	96	FT02	LU5D 1200	F03FS05301
300	3,5	3,0	32	96	2/11/63	LU5D 1300	F03FS05303
300	3,5	3,0	40	96	2/9/55+4/12/64	LU5D 1400	F03FS05305
330	3,5	3,0	30	104	FT02	LU5D 1500	F03FS05306
330	3,5	3,0	32	104	2/11/63	LU5D 1600	F03FS05308
350	3,5	3,0	30	108	FT02	LU5D 1700	F03FS05309
350	3,5	3,0	32	108	2/11/63	LU5D 1800	F03FS05311
350	3,5	3,0	40	108	2/9/55+4/12/64	LU5D 1900	F03FS05313
370	3,5	3,0	30	108		LU5D 2000	F03FS05314
380	3,5	3,0	32	108	2/11/63	LU5D 2200	F03FS05315
400	3,5	3,0	30	120		LU5D 2300	F03FS05316
400	3,5	3,0	32	120	2/11/63	LU5D 2400	F03FS05317
400	3,5	3,0	40	120	2/15/80+2/12/64	LU5D 2500	F03FS05318
400	3,5	3,0	50	120	4/15/80	LU5D 2600	F03FS05319
420	4,0	3,2	30	120	2/11/70	LU5D 2700	F03FS05320
420	4,0	3,2	40	120		LU5D 2800	F03FS05321
450	4,0	3,2	30	128		LU5D 2900	F03FS05322
500	4,0	3,2	32	140	2/11/63	LU5D 3400	F03FS05323

GATECH  
www.freud.rs

	Ultimate Najbolja	High Odlična	Good Dobra
Non-ferrous metals Obojeni metali	●		
Plastic materials Plastični materijali	●		
PVC		●	
PVC			●

# LU5E

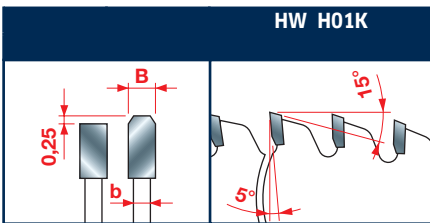

Tooth features - Karakteristike zuba

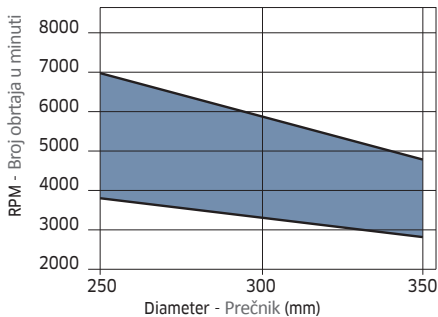

Minimum and maximum RPM based on the blade diameter.

Minimalan i maksimalan broj obrtaja u odnosu na prečnik testere.

## HW - Saw blades to cut non-ferrous metals TM - Testere za rezanje aluminijuma (obojenih metala)

To cut special drawn products, such as tubes and similar products having ultrathin walls. The reduced thickness allows an excellent cutting finish, without splintering, and optimises its employment in low-power machines, too.

**Machines:** Miter saws with mechanical clamping of the piece.

**Features:** Flat-triple chip tooth with positive cutting angle.

**Material:** Aluminum, non-ferrous metals.

Testere za rezanje materijala i cevi izuzetno male debljine. Smanjena debljina tela omogućava odličan završni rez, bez krzanja. Zahvaljujući njoj, ove testere se mogu koristiti i na mašinama male snage.

**Mašine:** Gerovi sa stezanjem komada.

**Oblik zuba:** Naizmjenično ravni i trapezni sa negativnim uglom rezanja.

**Materijal:** Aluminijum i obojeni metali

**FT01:** 2/7/42 + 2/9/46,4 + 2/10/60

**FT02:** 2/9/46,4 + 2/10/60

D	B	b	d	Z	NL	Code	SAP
mm	mm	mm	mm		Pomoćni otvori	Šifra	SAP
250	2,8	2,2	30	100	FT01	LU5E 0100	F03FS05324
250	2,8	2,2	32	100	2/11/63	LU5E 0200	F03FS05325
255	2,8	2,2	25,4	100		LU5E 0300	F03FS05327
255	2,8	2,2	25,4	120		LU5E 0400	F03FS05329
300	3,0	2,5	30	100	FT02	LU5E 0500	F03FS05331
300	3,0	2,5	30	120	FT02	LU5E 0700	F03FS05334
300	3,0	2,5	32	120	2/11/63	LU5E 0800	F03FS05337
305	3,0	2,5	25,4	120		LU5E 0600	F03FS05333
350	3,0	2,5	30	100	FT02	LU5E 0900	F03FS05339
350	3,0	2,5	32	100	2/11/63	LU5E 1000	F03FS05340
350	3,0	2,5	30	120	FT02	LU5E 1100	F03FS05341
350	3,0	2,5	32	120	2/11/63	LU5E 1200	F03FS05342

GATECH  
www.freud.rs

Ultimate	High	Good
Najbolja	Odlična	Dobra

Non-ferrous metals  
Aluminijum (obojeni metali)



# LU5F

**new**  
**ново**

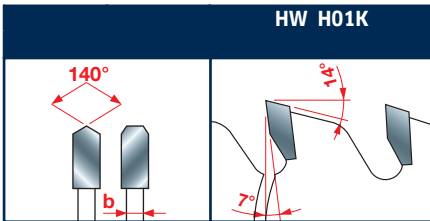

Tooth features - Karakteristike zuba

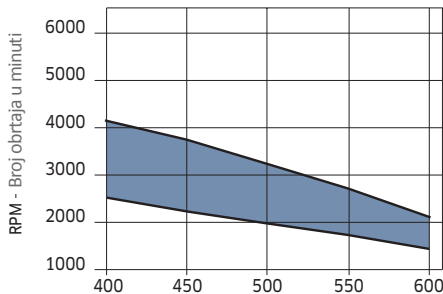

Diameter - Prečnik (mm)

Minimum and maximum RPM based on the blade diameter.

Minimalan i maksimalan broj obrtaja u odnosu na prečnik testere.

## HW - Saw blades to cut non-ferrous metals and PVC TM - Testere za rezanje aluminijuma (obojenih metala) i PVC-a

Saw blades for cutting thin wall aluminum profiles up to 4,5 mm for doors and windows, also including built-in plastic profiles.

**Machines:** Automatic machines with single or double head.

**Features:** PYRAMID tooth design, an innovative geometry concept that significantly reduces the wear of the cutting edge. The super polished cutting edges further reduce the sticking of the aluminum chips to the surface. The Black EXrim coating, directly expels the aluminum chips from the gullets. It avoids the chips getting welded with the steel body and making the surface dull.

**Material:** Aluminum and non-ferrous metals, PVC extruded profiles.

Testere za rezanje tankih aluminijumskih profila za vrata i prozore debljine do 4,5mm, praznih ili ispunjenih PVC-om.

**Mašine:** Automatski gerovi sa jednom ili dve glave.

**Oblik zuba:** PIRAMIDALNI zub inovativne geometrijske koncepcije, koji značajno smanjuje trošenje reznih površina. Super-polirane rezne ivice dodatno smanjuju lepljenje opiljaka aluminijuma za površinu. Crni ExRim zaštitni sloj direktno izbacuje opiljke iz prostora između zuba. To ih sprečava da se zalepe za površinu profila i oštete je.

**Materijal:** Aluminijum i obojeni metali, PVC ekstrudirani profili.

	D	B	b	d	Z	FT	Code	SAP
	mm	mm	mm	mm		Pomoćni otvori	Šifra	SAP
novi	400	3,5	3,0	30	96	2/11/63 - 2/11/70	LU5F40001	F03FS07683
novi	400	3,5	3,0	32	96	2/11/63 - 2/11/70	LU5F40002	F03FS07684
novi	400	3,5	3,0	30	120	2/11/63 - 2/11/70	LU5F40003	F03FS07685
novi	400	3,5	3,0	32	120	2/11/63 - 2/11/70	LU5F40004	F03FS07686
novi	420	3,5	3,0	30	100	2/11/63 - 2/11/70	LU5F42001	F03FS07687
novi	420	3,5	3,0	32	100	2/11/63 - 2/11/70	LU5F42002	F03FS07688
novi	450	3,5	3,0	30	108	2/11/63 - 2/11/70	LU5F45001	F03FS07689
novi	450	3,5	3,0	32	108	2/11/63 - 2/11/70	LU5F45002	F03FS07690
novi	500	4,0	3,5	30	120	2/11/63 - 2/11/70	LU5F50001	F03FS07691
novi	500	4,0	3,5	32	120	2/11/63 - 2/11/70	LU5F50002	F03FS07692
novi	530	4,0	3,5	30	126	2/11/63 - 2/11/70	LU5F53001	F03FS07693
novi	530	4,0	3,5	32	126	2/11/63 - 2/11/70	LU5F53002	F03FS07694
novi	550	4,0	3,5	30	132	2/11/63 - 2/11/70	LU5F55001	F03FS07695
novi	550	4,0	3,5	32	132	2/11/63 - 2/11/70	LU5F55002	F03FS07696
novi	600	4,7	4,0	30	144	2/11/63 - 2/11/70	LU5F60001	F03FS07697
novi	600	4,7	4,0	32	144	2/11/63 - 2/11/70	LU5F60002	F03FS07698
novi	600	4,7	4,0	30	156	2/11/63 - 2/11/70	LU5F60003	F03FS07699
novi	600	4,7	4,0	32	156	2/11/63 - 2/11/70	LU5F60004	F03FS07700

**GATECH**  
[www.freud.rs](http://www.freud.rs)

	Ultimate Najbolja	High Odlična	Good Dobra
Non-ferrous metals Obojeni metali	●		
Plastic materials Plastični materijali	●		
PVC PVC		●	

# LU6A



## HW - Saw blades to cut ferrous metals TM- Testere za rezanje gvožđa (crnih metala)

To cut drawn products, tubes and iron rods.

**Machines:** Miter saws in low-power dry cut (without lubricants).

**Features:** Double-triple chip tooth.

**Material:** For ferrous metals, mild steel, copper etc.

**WARNING: The above-mentioned saw blades are not suitable to cut the following materials:**

- Non-ferrous metals (aluminum).
- Wood, glass, conglomerate, etc.

Make sure that the workpieces to be cut are well fastened.

Testere za rezanje gvozdenih cevi i šipki.

**Mašine:** Gerovi manje brzine za suvo rezanje (bez podmazivanja).

**Oblik zuba:** Kombinacija trapeznih zuba sa dvostrukom i trostrukom reznom ivicom.

**Materijal:** Gvožđe i crni metali, meki čelik, bakar...

**UPOZORENJE: Ove testere NISU pogodne za rezanje sledećih materijala:**

- Aluminijuma i obojenih metala
- Drveta, stakla, polimernih materijala...

Pobrinite se da komad koji se reže bude dobro stegnut.

**FT01:** 2/7/42 + 2/9/46,4 + 2/10/60

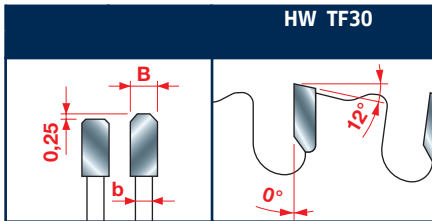

Tooth features - Karakteristike zuba

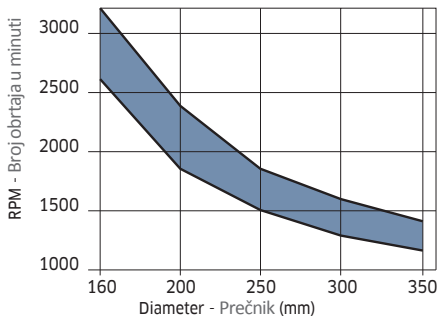

Minimum and maximum RPM based on the blade diameter.

Minimalan i maksimalan broj obrtaja u odnosu na prečnik testere.

Saw blade diameter Prečnik testere	Maximum RPM MAX obrtaja/min
160 mm	3.200
184 mm	3.000
190 mm	2.600
210 mm	2.300
216 mm	2.200
230 mm	2.100
250 mm	1.900
255 mm	1.900
300 mm	1.800
305 mm	1.800
315 mm	1.700
350 mm	1.600
355 mm	1.600
400 mm	1.400

Table of maximum RPM based on the blade diameter, for saw blades to cut ferrous metals.  
Tabela maksimalnog broja obrtaja u minuti u odnosu na prečnik testere za rezanje gvožđa i crnih metala.

D mm	B mm	b mm	d mm	Z	NL Pomoćni otvori	Code Šifra	SAP SAP
160	2,0	1,6	20	30		LU6A 0100	F03FS05343
184	2,0	1,6	15,88	38		LU6A 0200	F03FS05344
184	2,0	1,6	15,88	48		LU6A 1900	F03FS06586
190	2,0	1,6	30	38		LU6A 0300	F03FS05345
210	2,0	1,6	30	40		LU6A 0400	F03FS05346
216	2,0	1,6	30	40		LU6A 0500	F03FS05347
230	2,2	1,8	30	48	FT01	LU6A 0600	F03FS05348
230	2,4	2,0	25,4	44		LU6A 0700	F03FS05349
250	2,4	2,0	30	48	FT01	LU6A 0800	F03FS05350
254	2,4	2,0	25,4	50		LU6A 0900	F03FS05351
254	2,4	2,0	25,4	60		LU6A 1000	F03FS05352
300	2,6	2,2	30	60	FT01	LU6A 1700	F03FS05359
300	2,6	2,2	30	80	FT01	LU6A 1800	F03FS05360
305	2,6	2,2	25,4	60		LU6A 1100	F03FS05353
305	2,6	2,2	25,4	80		LU6A 1200	F03FS05354
350	2,6	2,2	30	72	FT01	LU6A 1300	F03FS05355
350	2,6	2,2	30	90	FT01	LU6A 1400	F03FS05356
355	2,6	2,2	25,4	72		LU6A 1500	F03FS05357
355	2,6	2,2	25,4	90		LU6A 1600	F03FS05358

GATECH  
www.freud.rs

Ferrous metals  
Gvožđe i crni metali

Ultimate Najbolja	High Odlična	Good Dobra
●		



# LP20M

## HW - Saw blades to cut solid wood TM - Testere za rezanje masiva

These blades are designed with a low number of teeth and are particularly fit for long grain cutting solid wood. These blades give a good finish if used in this way.

**Machines:** Portable machines.

**Features:** ATB 15° tooth with positive cutting angle.

**Material:** Solid soft and hardwood.

Ove testere dizajnirane su sa malim brojem zuba i posebno su dobre za uzdužno rezanje masiva. Daju odličan kvalitet završnog reza.

**Mašine:** Ručni cirkulari.

**Oblik zuba:** ATB 15° sa pozitivnim uglom rezanja.

**Materijal:** Meko i tvrdo drvo (masiv).

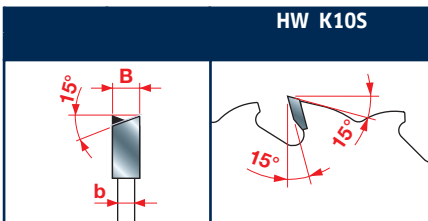

Tooth features - Karakteristike zuba

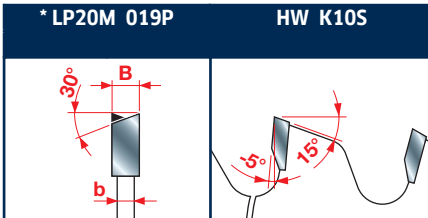

Tooth features - Karakteristike zuba

D	B	b	d	Z	NL	Code	SAP
mm	mm	mm	mm		Pomoćni otvori	Šifra	SAP
150	2,4	1,6	16	12		LP20M 004P	F03FS03612
150	2,4	1,6	20	12	2/6/32	LP20M 005P	F03FS03613
160	2,4	1,6	16	12		LP20M 006P	F03FS03614
160	2,4	1,6	20	12	2/6/32	LP20M 007P	F03FS03615
160	2,4	1,6	30	12	2/6/42	LP20M 008P	F03FS03616
180	2,4	1,6	20	12	2/6/32	LP20M 010P	F03FS03618
180	2,4	1,6	30	12	2/6/42	LP20M 011P	F03FS03619
184	2,4	1,6	16	12		LP20M 012P	F03FS03620
190	2,4	1,6	16	12		LP20M 013P	F03FS03621
190	2,4	1,6	20	12	2/6/32	LP20M 014P	F03FS03622
190	2,4	1,6	30	12	2/6/42	LP20M 015P	F03FS03623
200	2,4	1,6	30	16	2/6/42	LP20M 016P	F03FS03624
210	2,4	1,6	25	16		LP20M 017P	F03FS03625
210	2,4	1,6	30	16	2/6/42	LP20M 018P	F03FS03626
216	2,4	1,8	30	24*	2/6/42	LP20M 019P	F03FS03627
220	2,4	1,6	30	16	2/6/42	LP20M 020P	F03FS03628
230	2,8	1,8	30	20	2/6/42	LP20M 021P	F03FS03629
235	2,8	1,8	30	24	2/6/42	LP20M 023P	F03FS03631
240	2,8	1,8	30	24	2/6/42	LP20M 024P	F03FS03632
250	2,8	1,8	30	24	2/6/42	LP20M 025P	F03FS03633

GATECH  
www.freud.rs

	Ultimate Najbolja	High Odlična	Good Dobra
Ripping and crosscutting of softwood Uzdužno i poprečno rezanje mekog drveta		●	
Ripping and crosscutting of hardwood Uzdužno i poprečno rezanje tvrdog drveta		●	

# LP30M

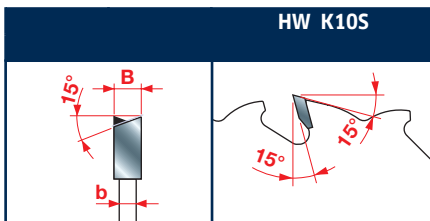
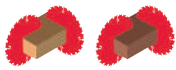

Tooth features - Karakteristike zuba

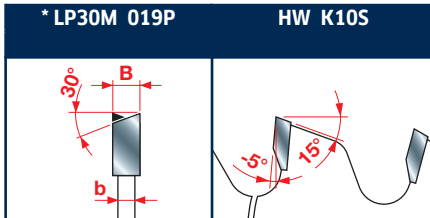

Tooth features - Karakteristike zuba

## HW - Saw blades to cut solid wood TM - Testere za rezanje masiva

These blades are designed with an average number of teeth and are particularly fit for both long grain and cross grain cutting solid wood. These blades give a good finish if used in this way.

**Machines:** Portable machines.

**Features:** ATB 15° tooth with positive cutting angle.

**Material:** Solid soft and hardwood.

Ove testere dizajnirane su sa prosečnim brojem zuba i posebno su dobre za uzdužno i poprečno rezanje masiva. Daju odličan kvalitet završnog reza.

**Mašine:** Ručni cirkulari.

**Oblik zuba:** ATB 15° sa pozitivnim uglom rezanja.

**Materijal:** Meko i tvrdo drvo (masiv).

D	B	b	d	Z	NL	Code	SAP
mm	mm	mm	mm		Pomoćni otvori	Šifra	SAP
125	2,4	1,6	20	24	2/6/32	LP30M 001P	F03FS03636
130	2,4	1,6	20	24	2/6/32	LP30M 002P	F03FS03637
140	2,4	1,6	20	24	2/6/32	LP30M 003P	F03FS03638
150	2,4	1,6	16	24		LP30M 004P	F03FS03639
150	2,4	1,6	20	24	2/6/32	LP30M 005P	F03FS03640
160	2,4	1,6	16	24		LP30M 006P	F03FS03642
160	2,4	1,6	20	24	2/6/32	LP30M 007P	F03FS03643
160	2,4	1,6	30	24	2/6/42	LP30M 008P	F03FS03644
170	2,4	1,6	30	24	2/6/42	LP30M 009P	F03FS03646
180	2,4	1,6	20	24	2/6/32	LP30M 010P	F03FS03647
180	2,4	1,6	30	24	2/6/42	LP30M 011P	F03FS03649
184	2,4	1,6	16	24		LP30M 012P	F03FS03652
190	2,4	1,6	16	24		LP30M 013P	F03FS03655
190	2,4	1,6	20	24	2/6/32	LP30M 014P	F03FS03657
190	2,4	1,6	30	24	2/6/42	LP30M 015P	F03FS03658
200	2,4	1,6	30	30	2/6/42	LP30M 016P	F03FS03660
210	2,4	1,6	25	30		LP30M 017P	F03FS03662
210	2,4	1,6	30	30	2/6/42	LP30M 018P	F03FS03663
216	2,4	1,8	30	48*	2/6/42	LP30M 019P	F03FS03665
220	2,4	1,6	30	30	2/6/42	LP30M 020P	F03FS03667
230	2,8	1,8	30	34	2/6/42	LP30M 021P	F03FS03669
235	2,8	1,8	25	34		LP30M 022P	F03FS03671
235	2,8	1,8	30	34	2/6/42	LP30M 023P	F03FS03673
240	2,8	1,8	30	36	2/6/42	LP30M 024P	F03FS03675
250	2,8	1,8	30	40	2/6/42	LP30M 025P	F03FS03677

GATECH  
www.freud.rs

	Ultimate Najbolja	High Odlična	Good Dobra
Ripping and crosscutting of softwood Uzdužno i poprečno rezanje mekog drveta		●	
Ripping and crosscutting of hardwood Uzdužno i poprečno rezanje tvrdog drveta		●	

# LP40M

## HW - Saw blades to cut solid wood TM - Testere za rezanje masiva

These blades are designed with a high number of teeth and are particularly fit for cross grain cutting solid wood. These blades give a good finish if used in this way.

**Machines:** Portable machines.

**Features:** ATB 15° tooth with positive cutting angle.

**Material:** Solid soft and hardwood.

Ove testere dizajnirane su sa velikim brojem zuba i posebno su dobre za poprečno rezanje masiva. Daju odličan kvalitet završnog reza.

**Mašine:** Ručni cirkulari.

**Oblik zuba:** ATB 15° sa pozitivnim uglom rezanja.

**Materijal:** Meko i tvrdo drvo (masiv).

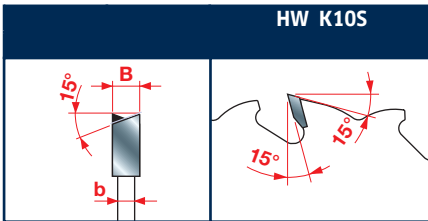

Tooth features - Karakteristike zuba

D	B	b	d	Z	NL	Code	SAP
mm	mm	mm	mm		Pomoćni otvori	Šifra	SAP
160	2,4	1,6	16	40		LP40M 006P	F03FS03701
160	2,4	1,6	20	40	2/6/32	LP40M 007P	F03FS03702
160	2,4	1,6	30	40	2/6/42	LP40M 008P	F03FS03703
170	2,4	1,6	30	40	2/6/42	LP40M 009P	F03FS03704
180	2,4	1,6	20	40	2/6/32	LP40M 010P	F03FS03705
180	2,4	1,6	30	40	2/6/42	LP40M 011P	F03FS03706
184	2,4	1,6	16	40		LP40M 012P	F03FS03708
190	2,4	1,6	16	40		LP40M 013P	F03FS03711
190	2,4	1,6	20	40	2/6/32	LP40M 014P	F03FS03712
190	2,4	1,6	30	40	2/6/42	LP40M 015P	F03FS03713
200	2,4	1,6	30	40	2/6/42	LP40M 016P	F03FS03714
210	2,4	1,6	25	40		LP40M 017P	F03FS03715
210	2,4	1,6	30	40	2/6/42	LP40M 018P	F03FS03716
220	2,4	1,6	30	40	2/6/42	LP40M 020P	F03FS03720
230	2,8	1,8	30	48	2/6/42	LP40M 021P	F03FS03721
235	2,8	1,8	25	48		LP40M 022P	F03FS03722
235	2,8	1,8	30	48		LP40M 023P	F03FS03724
240	2,8	1,8	30	48	2/6/42	LP40M 024P	F03FS03725
250	2,8	1,8	30	60	2/6/42	LP40M 025P*	F03FS03727

\* Item LP40M 025P is not designed with anti-kickback.

\* Artikel LP40M 025P nema zaštitu protiv odskakanja komada.

GATECH  
www.freud.rs

Ultimate Najbolja	High Odlična	Good Dobra
----------------------	-----------------	---------------

Crosscutting of soft and hardwood  
Poprečno rezanje mekog drveta (masiva)



# LP70M

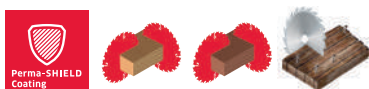

## HW - Saw blades for on-site jobs TM - Testere za rezanje na terenu

Saw blades suitable for ripping and crosscutting.

**Machines:** Table saws.

**Features:** ATB tooth with positive cutting angle.

**Material:** Soft and hard solid wood and panels, even in case of nails or metal clips.

Testere predviđene za uzdužno i poprečno rezanje.

**Mašine:** Ručni cirkulari.

**Oblik zuba:** ATB sa pozitivnim uglom rezanja.

**Materijal:** Meko i tvrdo drvo (masiv), paneli, čak i kada sadrže eksere ili metalne klemarice.

D	B	b	d	Z	NL	Code	SAP
mm	mm	mm	mm		Pomoćni otvori	Šifra	SAP
300	2,8	1,8	30	24 *	2/10/60	LP70M 001P	F03FS03762
350	3,0	2,2	30	28 *	2/10/60	LP70M 002P	F03FS03763

D	B	b	d	Z	NL	Code	SAP	
mm	mm	mm	mm		Pomoćni otvori	Šifra	SAP	
300	2,6	1,8	25	24		LP70M 004P	F03FS03766	
315	3,2	2,2	30	24	2/10/50	LP70M 003P	F03FS03765	
315	3,2	2,2	25	48		LP70M 006P	F03FS03768	
400	3,8	2,8	30	28	2/10/60	LP70M 008P	F03FS03770	
<b>novi</b>	500	4,4	3,2	30	36	2/10/60	LP70M 010P	F03FS03772
<b>novi</b>	600	5,2	4,0	30	48	2/10/60	LP70M 012P	F03FS03774

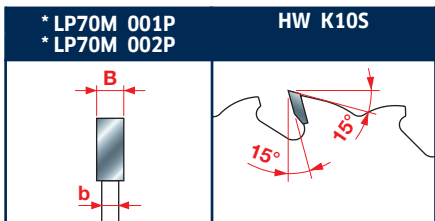

Tooth features - Karakteristike zuba

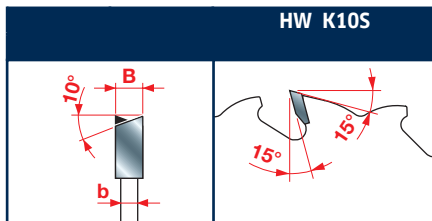

Tooth features - Karakteristike zuba

Ultimate	High	Good
Najbolja	Odlična	Dobra
	●	

Ripping and crosscutting of soft and hardwood  
Uzdužno i poprečno rezanje masiva

# LP60M



## HW - Saw blades for hardwood and softwood TM - Testere za rezanje tvrdog i mekog drveta

Saw blades suitable for ripping and crosscutting (see details).

**Machines:** Portable machines.

**Features:** ATB 15° tooth with positive cutting angle.

**Material:** Soft and hard solid wood.

Testere predviđene za uzdužno i poprečno rezanje (pogledaj detalje).

**Mašine:** Ručni cirkulari.

**Oblik zuba:** ATB 15° sa pozitivnim uglom rezanja.

**Materijal:** Meko i tvrdo drvo (masiv).

### For ripping

Za uzdužno rezanje

D	B	b	d	Z	NL	Code	SAP
mm	mm	mm	mm		Pomoćni otvori	Šifra	SAP
300	3,2	2,2	30	48	2/10/60	LP60M 014P	F03FS03744

Ultimate	High	Good
Najbolja	Odlična	Dobra
	●	

Ripping of soft and hardwood  
Uzdužno rezanje masiva

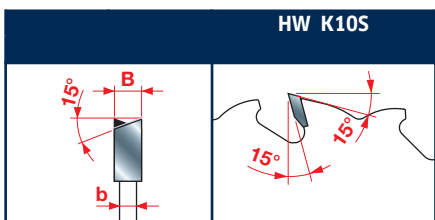

Tooth features - Karakteristike zuba

GATECH  
www.freud.rs

# LP60M

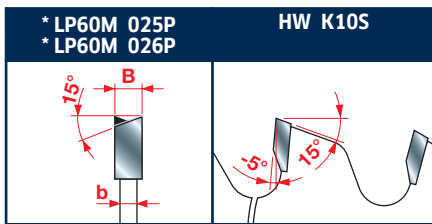

Tooth features - Karakteristike zuba

## HW - Saw blades for hardwood and softwood TM - Testere za rezanje tvrdog i mekog drveta

**For ripping and cross cutting**  
Za uzdužno i poprečno rezanje

D mm	B mm	b mm	d mm	Z	NL Pomoćni otvori	Code Šifra	SAP SAP
260	2,6	1,8	30	60	2/10/60	LP60M 013P	F03FS03743
300	2,8	1,8	30	48	2/10/60	LP60M 003P	F03FS03733
300	3,2	2,2	30	60	2/10/60	LP60M 015P	F03FS03745
<b>novo</b>	305	2,8	1,8	30	48*	LP60M 025P	F03FS06301
350	3,0	2,2	30	54	2/10/60	LP60M 007P	F03FS03737
350	3,5	2,5	30	72	2/10/60	LP60M 020P	F03FS03750

Ultimate Najbolja	High Odlična	Good Dobra
----------------------	-----------------	---------------

Ripping and crosscutting of soft and hardwood  
Uzdužno i poprečno rezanje masiva

**For cross cutting**  
Za poprečno rezanje

D mm	B mm	b mm	d mm	Z	NL Pomoćni otvori	Code Šifra	SAP SAP
250	3,2	2,2	30	60	2/10/60	LP60M 011P	F03FS03741
250	2,8	1,8	30	80	2/10/60	LP60M 001P	F03FS03731
280	2,8	1,8	30	64	2/10/60	LP60M 002P	F03FS03732
300	2,8	1,8	30	72	2/10/60	LP60M 004P	F03FS03734
300	2,8	1,8	30	96	2/10/60	LP60M 005P	F03FS03735
<b>novo</b>	305	2,8	1,8	30	72*	LP60M 026P	F03FS06302
305	2,8	1,8	30	96	2/10/60	LP60M 006P	F03FS03736
350	3,0	2,2	30	108	2/10/60	LP60M 008P	F03FS03738

Ultimate Najbolja	High Odlična	Good Dobra
----------------------	-----------------	---------------

Crosscutting of soft and hardwood  
Poprečno rezanje masiva

# LP67M **new** **novo**

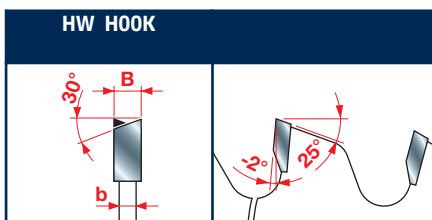
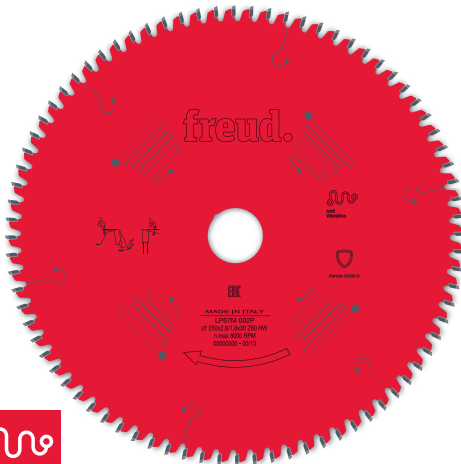

Tooth features - Karakteristike zuba

## HW - Saw blades to cut bilaminated panels TM - Testere za rezanje obostrano oplemenjenih pločastih materijala

To cut bilaminated panels.  
**Machines:** Benchtop and portable machines.  
**Features:** ATB 30° with negative cutting angle.  
**Material:** Bilaminated panels, chipboard or MDF.

Testere za rezanje obostrano oplemenjenih pločastih materijala.  
**Mašine:** Ručni cirkulari.  
**Oblik zuba:** ATB 30° sa negativnim uglom rezanja.  
**Materijal:** Obostrano oplemenjeni pločasti materijali, iverica i medijapan (MDF).

D mm	B mm	b mm	d mm	Z	NL Pomoćni otvori	Code Šifra	SAP SAP
<b>novo</b>	185	2,4	1,6	20	60	LP67M 001P	F03FS07261
<b>novo</b>	250	2,8	1,8	30	80	LP67M 002P	F03FS07262
<b>novo</b>	300	2,8	1,8	30	96	LP67M 003P	F03FS07263

GATECH  
www.freud.rs

Ultimate Najbolja	High Odlična	Good Dobra
----------------------	-----------------	---------------

Laminates  
Laminati



# LP40M

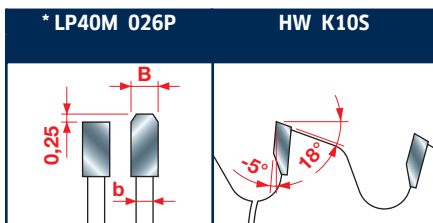
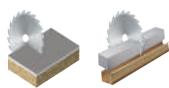

Tooth features - Karakteristike zuba

## HW - Saw blades to cut non-ferrous metals TM - Testere za rezanje aluminijuma i obojenih metala

To size bilaminated panels and to cut solid drawn products and tubes.

**Machines:** Portable machines.

**Features:** Flat-triple chip tooth with negative cutting angle.

**Material:** Bilaminated panels, aluminum and non-ferrous metals.

Testere za rezanje obostrano oplemenjenih pločastih materijala, profila i cevi od aluminijuma i obojenih metala.

**Mašine:** Ručni cirkulari.

**Oblik zuba:** Naizmjenično ravni i trapezni sa negativnim uglom rezanja.

**Materijal:** Obostrano oplemenjeni pločasti materijali, aluminijum i obojeni metali.

D	B	b	d	Z	NL	Code	SAP
mm	mm	mm	mm		Pomoćni otvori	Šifra	SAP
160	2,2	1,6	20	48 *		LP40M 026P	F03FS03729
216	2,4	1,8	30	64 **	2/6/42	LP40M 019P	F03FS03718

Ultimate Najbolja	High Odlična	Good Dobra
	●	
	●	

Non-ferrous metals  
Aluminijum i obojeni metali  
Laminates  
Laminati

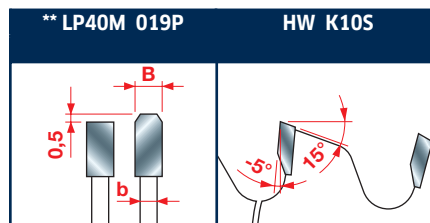

Tooth features - Karakteristike zuba

GATECH  
www.freud.rs

# LP80M

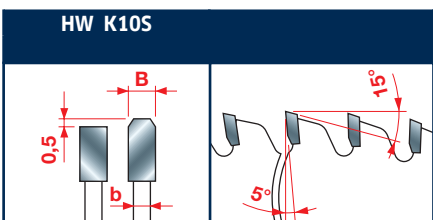

Tooth features - Karakteristike zuba

## HW - Saw blades to cut non-ferrous metals TM - Testere za rezanje aluminijuma i obojenih metala

To cut drawn products and tubes with a thickness between 2 and 5 mm, as well as polymeric panels up to 20 mm.

**Machines:** Portable machines.

**Features:** Flat-triple chip tooth with positive cutting angle.

**Material:** Aluminum and non-ferrous metals, polymeric materials.

testere za rezanje profila i cevi od aluminijuma i obojenih metala debljine od 2-5mm, kao i ploča od polimera debljine do 20mm.

**Mašine:** Ručni cirkulari.

**Oblik zuba:** Naizmjenično ravni i trapezni sa pozitivnim uglom rezanja.

**Materijal:** Aluminijum i obojeni metali, polimeri.

FT02: 2/9/46,4 + 2/10/60

D	B	b	d	Z	NL	Code	SAP
mm	mm	mm	mm		Pomoćni otvori	Šifra	SAP
250	2,8	2,2	30	80	2/10/60	LP80M 001P	F03FS03775
280	2,8	2,2	30	64	2/10/60	LP80M 002P	F03FS03776
300	2,8	2,2	30	96	2/10/60	LP80M 003P	F03FS03777
350	3,0	2,2	30	108	2/10/60	LP80M 004P	F03FS03778

Ultimate Najbolja	High Odlična	Good Dobra
	●	

Non-ferrous metals  
Aluminijum i obojeni metali

# LP85M

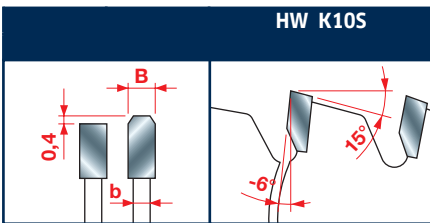
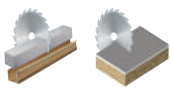

Tooth features - Karakteristike zuba

## HW - Saw blades to cut aluminum and bilaminated panels TM - Testere za rezanje aluminijuma i obostrano oplemenjenih pločastih materijala

To size bilaminated panels and to cut solid drawn products and tubes.

**Machines:** Portable machines.

**Features:** Flat-triple chip tooth with negative cutting angle.

**Material:** Bilaminated panels, aluminum and non-ferrous metals.

Testere za rezanje obostrano oplemenjenih pločastih materijala, kao i punih profila i cevi od aluminijuma i obojenih metala.

**Mašine:** Ručni cirkulari.

**Oblik zuba:** Najzmenično ravni i trapezni sa negativnim uglom rezanja.

**Materijal:** Obostrano oplemenjeni pločasti materijali, aluminijum i obojeni metali.

D mm	B mm	b mm	d mm	Z	NL Pomoćni otvori	Code Šifra	SAP SAP
150	2,8	2,0	20	42		LP85M 001P	F03FS06229
160	2,8	2,0	20	42		LP85M 002P	F03FS06230
180	2,8	2,0	30	48		LP85M 003P	F03FS06231
190	2,8	2,0	30	54		LP85M 004P	F03FS06232
200	2,8	2,0	30	54		LP85M 005P	F03FS06233
210	2,8	2,0	30	54		LP85M 006P	F03FS06234
230	2,8	2,0	30	64		LP85M 007P	F03FS06235
280	2,8	2,0	30	84	2/10/60	LP85M 008P	F03FS06223

Ultimate Najbolja	High Odlična	Good Dobra
	●	
	●	

Non-ferrous metals  
Aluminijum i obojeni metali  
Laminates  
Laminati

# LP90M

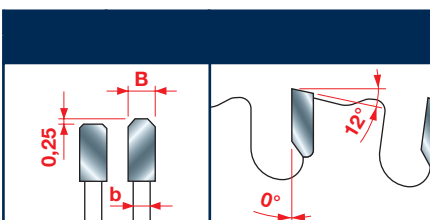
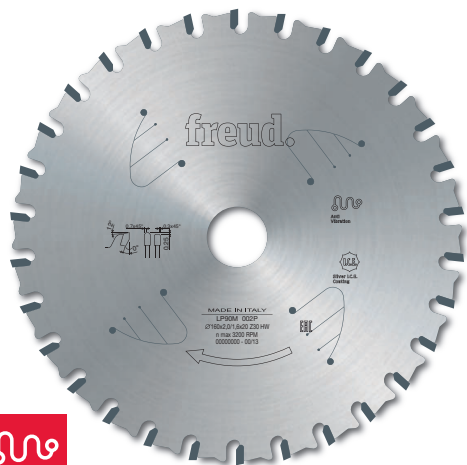

Tooth features - Karakteristike zuba

## HW - Saw blades to cut ferrous metals TM - Testere za rezanje gvožđa i crnih metala

To cut drawn products and tubes with a thickness up to 4 mm, dry cut (without lubricants).

**Machines:** Portable machines.

**Features:** Flat-triple chip tooth.

**Material:** For ferrous metals and soft steel.

Za rezanje punih profila i cevi debljine do 4mm. Suvo rezanje (bez podmazivanja).

**Mašine:** Ručni cirkulari.

**Oblik zuba:** Najzmenično ravni i trapezni sa pozitivnim uglom rezanja.

**Materijal:** Gvožđe, crni metali i meki čelik.

D mm	B mm	b mm	d mm	Z	NL Pomoćni otvori	Code Šifra	SAP SAP
160	2,0	1,6	20	30		LP90M 002P	F03FS07034
210	2,0	1,6	30	40		LP90M 005P	F03FS06239
230	2,2	1,8	30	44		LP90M 006P	F03FS06240

Ultimate Najbolja	High Odlična	Good Dobra
●		

Ferrous metals  
Gvožđe i crni metali

GATECH  
www.freud.rs

# LP91M

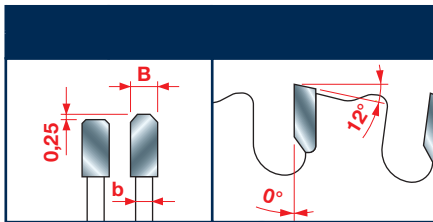

Tooth features - Karakteristike zuba

## HW - Saw blades to cut multi-material TM - Testere za rezanje više vrsta materijala

To cut iron profiles, tubing and angles with a thickness up to 3,2 mm.

**Machines:** Portable machines and miter saws.

**Features:** Flat-triple chip tooth.

**Material:** For bilaminated, chipboard, MDF, plywood, ferrous and non-ferrous metals, aluminium, plexiglas and plastic materials.

Testere za rezanje gvozdениh profila, cevi i uglova debljine do 3,2mm.

**Mašine:** Ručni cirkulari i gerovi.

**Oblik zuba:** Naizmjenično ravni i trapezni sa pozitivnim uglom rezanja.

**Materijal:** Obostrano oplemenjeni pločasti materijali, medijapan (MDF), šper ploča, gvožđe i crni metali, aluminijum i obojeni metali, pleksiglas i plastični materijali.

**NAPOMENA:** Ove testere NISU pogodne za rezanje drveta (masiva)!

D mm	B mm	b mm	d mm	Z	NL Pomoćni otvori	Code Šifra	SAP SAP
160	2,0	1,6	20	30		LP91M 001P	F03FS06251
190	2,0	1,6	30	38		LP91M 002P	F03FS06252
216	2,0	1,6	30	40		LP91M 003P	F03FS06253
230	2,4	2,0	30	44		LP91M 004P	F03FS06254
250	2,4	2,0	30	48		LP91M 005P	F03FS06255
305	2,8	2,0	30	80		LP91M 006P	F03FS06256

	Ultimate Najbolja	High Odlična	Good Dobra
Laminates and wood composites Laminati i drveni kompoziti		●	
Veneered Furnir		●	
Non-ferrous metals Aluminijum i obojeni metali		●	
Ferrous metals Gvožđe i crni metali		●	
Plexiglas & plastic materials Pleksiglas i plastični materijali		●	
PVC PVC		●	
Solid surfaces Radne ploče		●	

GATECH  
www.freud.rs

# BL15M - BL20M

## Standard reduction rings for saw blades Standardni redukcioni prstenovi za testere

D mm	B mm	d mm	Code Šifra	SAP SAP
20	1,5	16	BL15M20160	F03FC00695
30	1,5	20	BL15M30200	F03FC00699
30	1,5	25	BL15M30250	F03FC00700

D mm	B mm	d mm	Code Šifra	SAP SAP
30	2,0	20	BL20M30200	F03FC00706
30	2,0	25	BL20M30250	F03FC00708
32	2,0	30	BL20M32300	F03FC00712

# OPT06

## Optional workings - Standard keyways Opcije izrade - Standardni klinovi

D mm	B mm	Code Šifra	SAP SAP
10	5	OPT06 AA9	F03FC16213
12	5	OPT06 BA9	F03FC16214
12,5	4	OPT06 CA9	F03FC16215
13	5	OPT06 DA9	F03FC16216
15	5	OPT06 EA9	F03FC16217
17	5	OPT06 FA9	F03FC16218
18	5	OPT06 GA9	F03FC16219
21	5	OPT06 HA9	F03FC16220

# OPT07

## Optional workings - Special keyways Opcije izrade - Specijalni klinovi

Code Šifra	SAP SAP
OPT07 AA9	F03FC16221

# OPT08

## Optional workings - Special reboring Opcije izrade - Proširenje rupa

Code Šifra	SAP SAP
OPT08 AA9	F03FC16222

# OPTFO

## Optional workings - Safety pin holes for saw blades Opcije izrade - Pomoćne rupe za testere

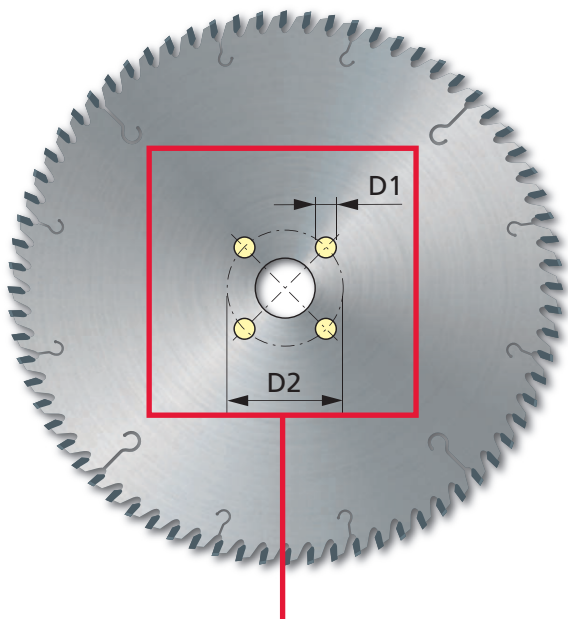

Number of holes Broj rupa	Code Šifra	SAP SAP
1	OPTFO AA9	F03FC16103
2	OPTFO AB9	F03FC16104
3	OPTFO AC9	F03FC16105
4	OPTFO AD9	F03FC16106
5	OPTFO AE9	F03FC16107
6	OPTFO AF9	F03FC16108
7	OPTFO AG9	F03FC16109
8	OPTFO AM9	F03FC16111
10	OPTFO AH9	F03FC16110

Specify no. of pin holes, diameter (D1) and distance between the centers of the pin holes (D2).  
Dostavite nam broj pomoćnih rupa, prečnik (D1) i rastojanje između centara rupa (D2).

# Tips for the correct use of a saw blade

## Saveti za ispravno korišćenje testere



# Tips for the correct use of a saw blade

## Saveti za ispravno korišćenje testere

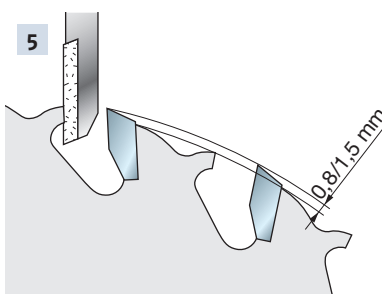
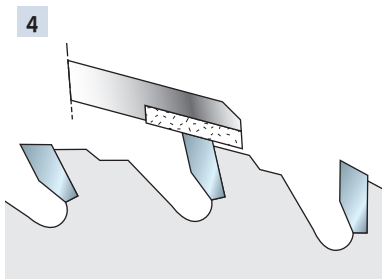
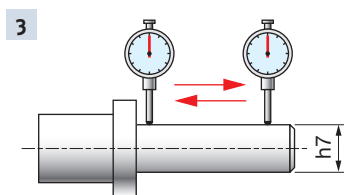
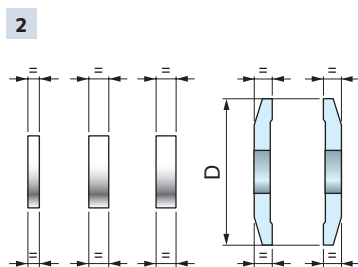
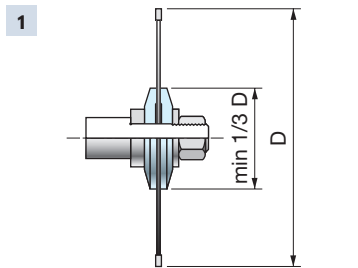

To obtain the best performance from a saw blade we suggest to follow these simple instructions:

- The machine must be in good condition, free of vibrations.
- The flanges used to secure the blade must be of the same diameter, at least 1/3 of the blade's diameter (Fig. 1).
- The flanges must be parallel to each other. Also check tolerances on diameters, sides and concentricity, by using a clock gauge (Fig. 2).
- The spacers must be perfectly parallel (Fig. 2).
- The spindle must be perfectly straight and with an H7 tolerance (Fig. 3).
- After continuous use, remove the blade and clean it with the appropriate solvents making sure to get rid of built up resin. For the synthetic coated (perma-SHIELD) blades, it's sufficient to use warm water. In any case, avoid using solvents containing caustic soda.
- The blades must be sharpened as soon as they become dull, maintaining the original tooth angles.
- For sharpening, always use the correct grinding wheels and plenty of cooling liquid.
- Always keep spacers and flanges clean.
- When sharpening, the shoulder of the teeth must not be lowered more than needed. This operation must be done with appropriate precision machinery and never by hand. There is the risk of breaking the tip or upsetting the blade balance (Fig. 4 - 5).
- On ripping machines, the feeding track must be levelled with the fixed table.
- Before starting the cut of the material, make sure the blade is correctly locked according to the machine's specifications.

Da biste iskoristili najbolje performanse testere, predlažemo Vam da pratite ova jednostavna uputstva:

- Mašina na kojoj radite mora biti u dobrom stanju, bez vibracija.
- Flanšne kojima se steže testera moraju biti istih dimenzija, otprilike minimum 1/3 prečnika testere (Slika 1).
- Flanšne za stezanje moraju biti paralelno postavljene. Proverite da li su dobro postavljene i pričvršćene pre započinjanja radova (Slika 2).
- Distantni prstenovi moraju biti savršeno paralelni (Slika 2)
- Osovina mora biti ravna i u toleranciji h7 (Slika 3).
- Nakon duže upotrebe, skinite testeru sa mašine i operite je odgovarajućim sredstvom da biste sprečili nagomilavanje otpadaka po njoj. Za testere sa sintetičkom (perma-SHIELD) prevlakom, dovoljno je da upotrebite toplu vodu. U svakom slučaju, izbegavajte upotrebu rastvora koji u sebi sadrže kaustičnu sodu.
- Naoštrite testere čim primetite da su tupe, zadržavajući originalne uglove zuba.
- Prilikom oštrenja uvek koristite odgovarajuće brusne ploče i dovoljno tečnosti za rashlađivanje.
- Vodite računa da distantni prstenovi i prirubnice budu uvek čisti.
- Telo iza zuba ne sme se spuštati više nego što je potrebno i to se nikada ne sme raditi ručno, jer postoji opasnost od lomljenja vrha i gubitka pravilnog balansa testere (Slike 4 - 5)
- Na višelisnim cirkularima, vučni valjci moraju biti u ravni sa fiksnim delom stola.
- Pre početka rezanja proverite da li je testera dobro fiksirana u skladu sa specifikacijama mašine.

**GATECH**  
www.freud.rs

# Tips for the correct use of a saw blade

## Saveti za ispravno korišćenje testere

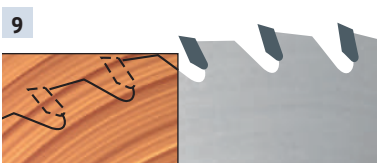
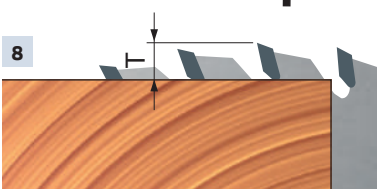
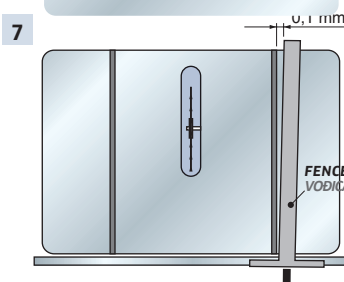
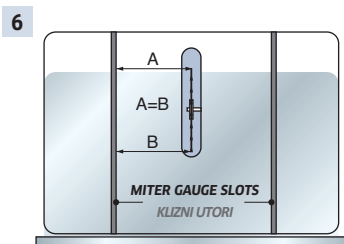

### SAW BLADE ALIGNMENT ON A TABLE SAW

- If the saw blade and the saw are not correctly aligned to the table and the fence, then there is the possibility that a serious accident may occur (for example, violent kickbacks) or that the workpiece may scorch or splinter. The first thing you must do is read the instruction sheet carefully. This is necessary so as you may acquire the understanding and comprehension of the corrections suggested in this section.
- Before carrying out the following instructions, make sure that the starter switch is off and that the machine is not connected to the socket.

#### Mounting the saw blade onto the table:

We advise you to use precise measuring instruments when mounting your saw blade. Clean the saw blade well, before mounting it onto the machine. Mount the saw blade onto the arbor. Adjust the arbor to its maximum height. With the aid of the most precise measuring instrument available, verify that the saw blade is parallel to the miter gauge slots (Fig. 6). Adjust as needed. This step is necessary to obtain crosscuts with the maximum in quality finish and for setting up the fence for ripping.

#### Positioning the fence for ripping:

After having positioned the saw blade so as it is parallel to the miter gauge slots, you may proceed with setting the fence. The fence should ideally be parallel to the saw blade. However since it is impossible to position the guide "exactly" it is necessary to leave a slight margin of clearance on the exit side of the cut so as to avoid the wood becoming wedged in between the fence and the saw blade.

Adjust the fence so as when it is aligned to the miter gauge slots, there is a space of 0,1 mm (fig. 7; for the correct adjustment, consult the machine's instruction manual).

- The maximum RPM of a circular saw blade varies according the diameter of the blade itself (table 1). If you exceed this limit, the saw blade will lose its characteristics, therefore influencing the cutting quality and the work life of the blade itself, not to mention the dangers implied to the user who may incur serious injury.
- The saw blade's projection (T) with respect to the workpiece must be at least equal to the height of the blade's tooth (fig. 8). Increase or decrease the projection of the saw blade to improve the quality of the cutting finish.
- The number of teeth cutting (teeth cutting the wood simultaneously - fig. 9) must be between 3 or 4. With less than three teeth cutting, the saw blade begins to vibrate leading to an uneven cut. If you want to cut workpieces with increased thicknesses (S - fig. 11), but wish to maintain the same diameter saw blade, then use a blade with less teeth. If instead you want to cut workpieces with a reduced thickness, but also maintain the same diameter saw blade, then use a blade with more teeth.

Table 1 - Tabela 1

Saw blade diameter Prečnik testere	Maximum RPM Max OBRTAJA/MIN
100 mm	23.000
125 mm	18.000
150 mm	14.500
180 mm	11.500
185 mm	11.000
200 mm	10.000
225 mm	8.500
250 mm	8.000
255 mm	7.800
280 mm	7.100
300 mm	6.500
320 mm	6.000
350 mm	5.500
380 mm	5.000
400 mm	4.700
430 mm	4.400
450 mm	4.200
500 mm	3.750
550 mm	3.400
600 mm	3.100
630 mm	2.950
650 mm	2.800
700 mm	2.600
730 mm	2.500
760 mm	2.400
800 mm	2.250

Not valid for saw blades to cut ferrous metals.

Nije validno za testere za rezanje gvožđa i crnih metala.

### POSTAVLJANJE TESTERE NA MAŠINU

- Ukoliko testera i mašina nisu pravilno postavljene u odnosu na sto i vođicu, može doći do ozbiljnih nezgoda (npr, odskakanja komada) ili se komad može oštetiti. Prva stvar koju morate uraditi jeste da pažljivo pročitate uputstvo za rukovanje mašinom. Zahvaljujući tome, moći ćete i da razumete i primenite savete koje Vam u ovom delu kataloga dajemo.

- Pre primene saveta koje Vam dajemo, proverite da li je mašina isključena i da nema dovoda struje.

#### Postavljanje testere na sto:

- Savetujemo Vam da koristite tačne merne instrumente kada postavljate testeru. Pre postavljanja, testeru koja je radila dobro očistite. Postavite testeru na osovinu i dovedite je na maksimalnu visinu. Uz pomoć preciznog mernog instrumenta proverite da li je testera paralelna sa kliznim utorima (Slika 6). Podesite je na taj način. Ovaj korak je neophodan da bi se dobili poprečni rezovi maksimalnog kvaliteta završnog reza i da bi se postavila vođica za uzdužan rez.

#### Postavljanje vođice za poprečan rez:

- Kada ste postavili testeru paralelno sa kliznim utorima, možete pristupiti podešavanju vođice. Vođica bi u idealnim uslovima trebalo da bude paralelna sa testerom. Međutim, kako je nemoguće postaviti vođicu „apsolutno tačno“, potrebno je ostaviti malu marginu na izlaznoj strani reza da bi se izbeglo zaglavljivanje komada između vođice i testere. Podesite vođicu tako da bude otprilike oko 0,1mm između nje i kliznih utora (Slika 7). Za tačno podešavanje, pogledajte uputstvo koje ste dobili uz mašinu.
- Maksimalan broj obrtaja testere (RPM) zavisi od prečnika testere (Tabela 1). Ukoliko se ove vrednosti pređu, testeraće izgubiti svoja svojstva, što će direktno uticati na kvalitet reza i vek trajanja testere – da ne spominjemo i opasnost od povreda koje se mogu desiti ukoliko se testera ošteti.
- Projekcija testere (T) mora biti takva da ona bude viša (viri iz materijala) barem za visinu zuba (Slika 8). Smanjenje ili povećanje te visine uticaće na kvalitet završnog reza.
- Broj zuba koji se istovremeno nalaze u zahvatu (Slika 9) mora biti između 3 i 4. Ukoliko istovremeno kroz komad prodire manje od 3 zuba, testera počinje da vibrira i doći će do neravnomernog rezanja. Ukoliko želite da režete komad povećane visine (S – Slika 11), ali želite da zadržite istu dimenziju testere, koristite testere sa manjim brojem zuba. Ukoliko želite da režete komad manje visine, uz zadržavanje iste dimenzije testere, odlučite se za tetesru sa većim brojem zuba.

# Tips for the correct use of a saw blade

## Saveti za ispravno korišćenje testere

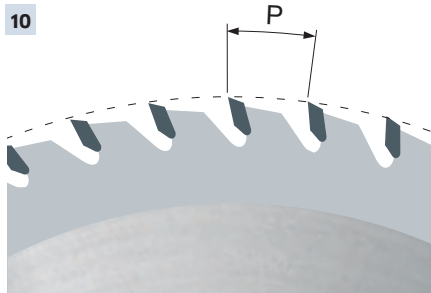

- To obtain the pitch (**P**) of a blade (the distance between teeth: fig. 10 - (see formula "a") multiply the thickness of the workpiece by 1,4142 and divide by 3 (if you want 3 teeth cutting) or by 4 (if you want 4 teeth cutting).
- Formula "b": to obtain the number of teeth (**Z**) of the saw blade, multiply the diameter (**D**) of the saw blade by 3,14 ( $\pi$ ) and divide by the pitch of the saw blade - obtained from the previous formula. The shorter formula "c" allows you to obtain the nr. of the saw blade's teeth, knowing its diameter and the thickness of the workpiece.
- Korak (**P**) je udaljenost između zuba (Sl. 10). Da biste ga dobili (vidi formulu "a"), pomnožite debljinu komada sa 1,4142 i podelite s 3 (ako želite 3 zuba u zahvatu) ili 4 (ako želite 4 zuba u zahvatu).
- Formula "b": za dobijanje broja zuba (**Z**) testere, pomnožite njen prečnik (**D**) s 3,14 ( $\pi$ ) i podelite s korakom (**P**) dobijenim u prethodnoj formuli. Kraća formula "c" omogućava da se dobije potreban broj zuba testere koristeći samo njen prečnik i debljinu komada koji se reže.

Formula A	Formula B	Formula C
$P = \frac{S \times 1,4142}{3}$	$Z = \frac{D \times 3,14}{P}$	$Z = \frac{D \times 8}{S}$

### KEY:

#### LEGENDA:

P=pitch / korak

S=thickness of the workpiece / debljina komada

Z=nr. teeth of the saw blade / broj zuba testere

D=diameter of the saw blade / prečnik testere

#### ATTENTION:

These formulas are valid for crosscutting and cutting other wood composites of (MDF, plywood, chipboard and laminated panels) and cannot be applied for ripping.

#### PAŽNJA:

Ove formule su validne za poprečno rezanje drveta i pločastih materijala (medijapana MDF, iverice, šper ploče i laminata) i ne mogu se primeniti na uzdužno rezanje.

**GATECH**  
www.freud.rs

# Tips for the correct use of a saw blade

## Saveti za ispravno korišćenje testere

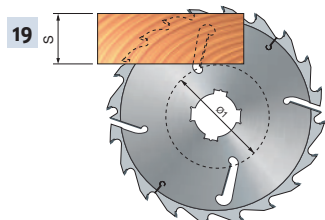
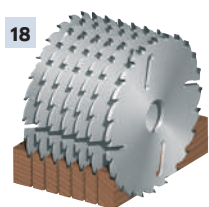
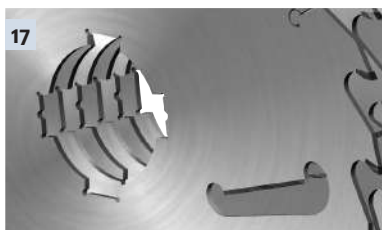
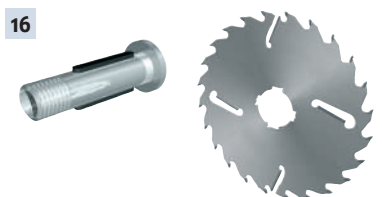
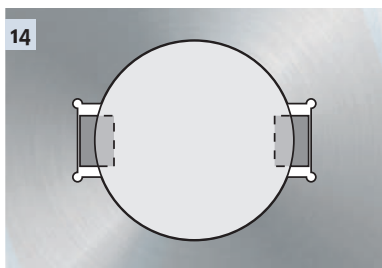
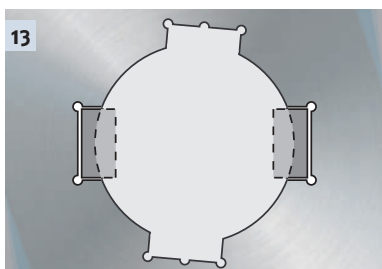
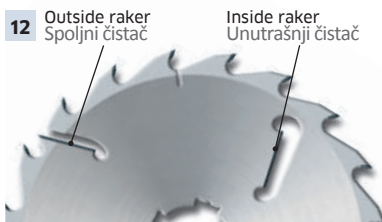

- Rakers (Fig. 12) are inserts in HW that are brazed onto saw blades exclusively for cutting wood. They help keep a distance between the saw blade body and the workpiece, in order to avoid friction and overheating which cause the blade to deform.
- On saw blades for multiripping machines the anti kick-back device is advised in cases where wood has loose knots and discards cases insert themselves underneath the saw blade.
- The pairing of blade and arbor with keyways is excellent in all cases where the keyways are the same (Fig. 13) or smaller then the blade slots (Fig. 14).
- On machines with an arbor with 1 keyway, you can only mount blades with 1 keyway slot (Fig. 15); on machines with an arbor with 2 keyways, you can only mount blades with 2 or 4 keyway slots (Fig. 16).
- You cannot mount a saw blade with 2 keyways on an arbor with 1 keyway slot, because the pairing will not be balanced.
- In case multiripping saw blades are used, it is recommendable to assembly them with alternate keyways (Fig. 17).
- Shoulder blade ensures correct distribution of lateral forces created by crooked planks in heavy duty use. The shoulder blade must be the first blade on the guide side of the multiripping machine.
- Always use shoulder blade with the set of multiripping blades (Fig. 18).
- On multiripping saw blades, the thickness of the workpiece (S) varies according to the diameter of the blade (Ø) and the minimum diameter (Ø1) of the rakers (the rakers position may vary from blade to blade - Fig. 19).

- Čistači (Slika 12) su TM pločice koje su lemljene na telo testera isključivo za rezanje drveta. Koriste se za odvajanje drveta od tela alata, kako bi se izbeglo trenje i pregrevanje što uzrokuje deformaciju testere.
- Na testerama za višelisne cirkulare, preporučuje se upotreba stezača protiv odskakanja komada, posebno u slučajevima kada drvo ima čvorove i kada se može desiti da ostaci komada koji se reže upadnu ispod testere.
- Pričvršćivanje testera za osovinu najbolje je kada postoje otvori koji odgovaraju dimenzijama klinova (Slika 13) ili su malo veći od dimenzija klinova (Slika 14).
- Na mašine čija osovinu ima jedan klin mogu se montirati samo testere koje imaju jedan otvor za klin (Slika 15), a na mašine čija osovinu ima dva klina mogu se montirati testere koje imaju dva ili četiri otvora za klinove (Slika 16).
- Testera sa dva otvora za klin ne može se montirati na osovinu sa jednim klinom, jer ne bi mogla dobro da se balansira.
- Ukoliko se vrši postavljanje više testera za višelisne cirkulare odjednom, preporuka je da se to radi tako što će se svaka od testera pomeriti za po jedan otvor u odnosu na prethodnu (Slika 17).
- Krajnja testera na višelisnim cirkularima mora biti jača od ostalih i postavlja se kao prva na ulaznoj strani komada. Ona osigurava pravilnu distribuciju lateralnih sila prilikom obrade komada.
- Uvek koristite krajnju testeru u setu testera za višelisni cirkular (Slika 18).
- Kada su u pitanju višelisni cirkulari, debljina komada (S) zavisi od prečnika testere (Ø) i minimalnog prečnika (Ø1) čistača (njihov položaj može varirati od testere do testere (Slika19)).

GATECH  
www.freud.rs



# Table 1 Tabela 1

Saw blade's technical table to obtain the correct saw blade diameter based on its tip speed and the material to cut  
Tabela za određivanje optimalnog prečnika testere prema perifernoj brzini i vrsti materijala za obradu

**GATECH**  
www.freud.rs

Tip speed (m/s) Periferna brzina u m/s	Recommended for Preporučuje se za
50 - 90	Softwood / Meko drvo
50 - 80	Hardwood / Tvrdo drvo
50 - 85	Exotic wood / Egzotično drvo
60 - 80	Chipboard / Iverica
60 - 80	Joinery wood / Panel ploče
30 - 60	MDF / Medijapan (MDF)
40 - 60	Laminated and bilaminated / Oplemenjeni materijali

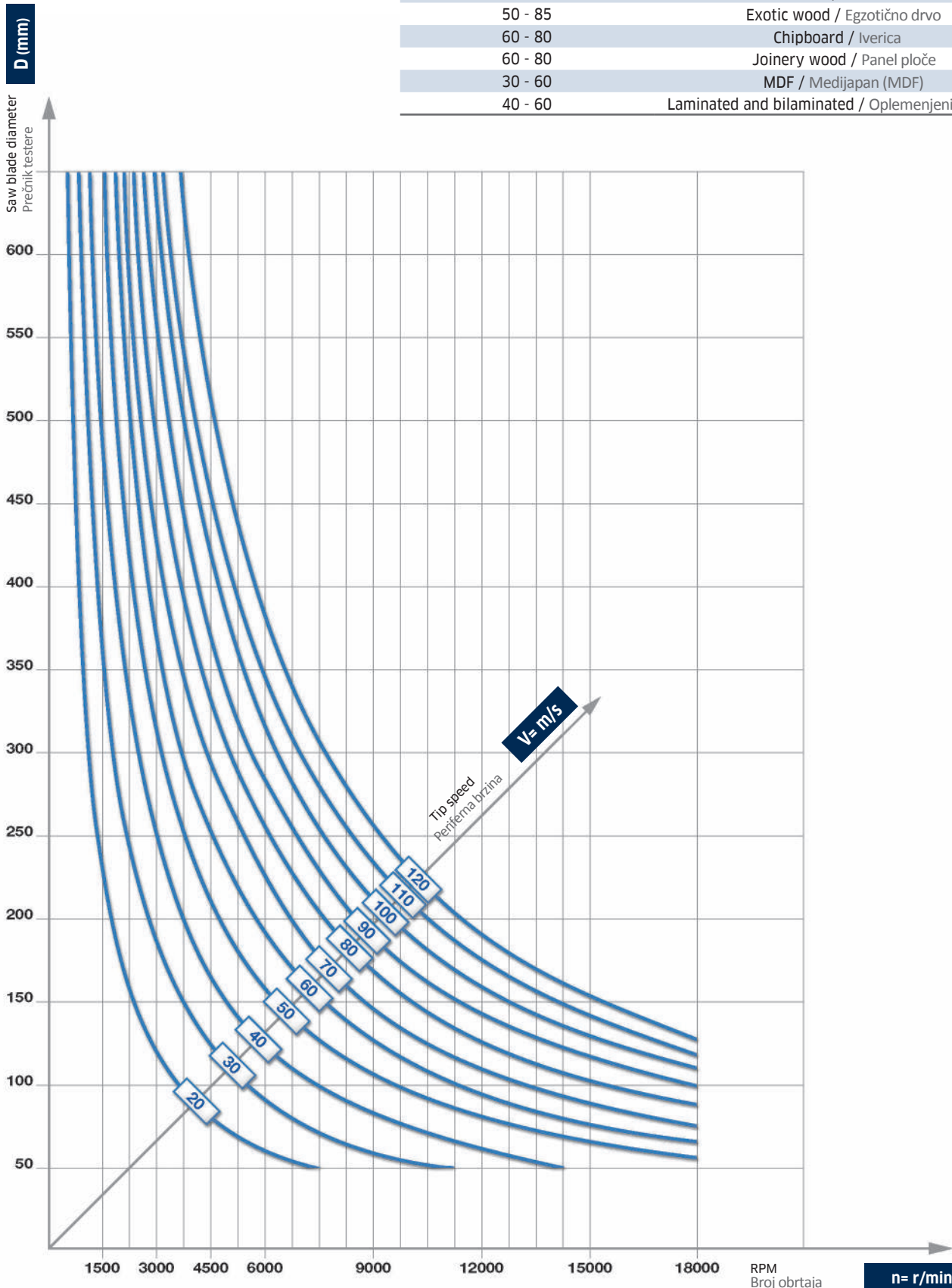



# Table 2 Tabela 2

Saw blade's technical table to obtain the correct tooth feed rate, the feed rate of the material, the number of teeth and the RPM  
Tabela za određivanje adekvatne brzine zuba, brzine ubacivanja komada, broja zuba i broja obrtaja (RPM)

Recommended tooth feed rate (Sz= mm/tooth) Preporučena brzina zuba (Sz= mm/zub)	Recommended for Preporučuje se za
0,20 - 0,30	Softwood ripping / Meko drvo uzdužno
0,10 - 0,20	Softwood crosscutting / Meko drvo poprečno
0,06 - 0,15	Hardwood / Tvrdo drvo
0,10 - 0,25	Chipboard / Iverica

Recommended tooth feed rate (Sz= mm/tooth) Preporučena brzina zuba (Sz= mm/zub)	Recommended for Preporučuje se za
0,05 - 0,12	Plywood / Šperploča
0,05 - 0,10	Laminated board / Oplemenjeni materijali
0,02 - 0,05	Aluminum and plastic laminated chipboard Aluminijum i laminati

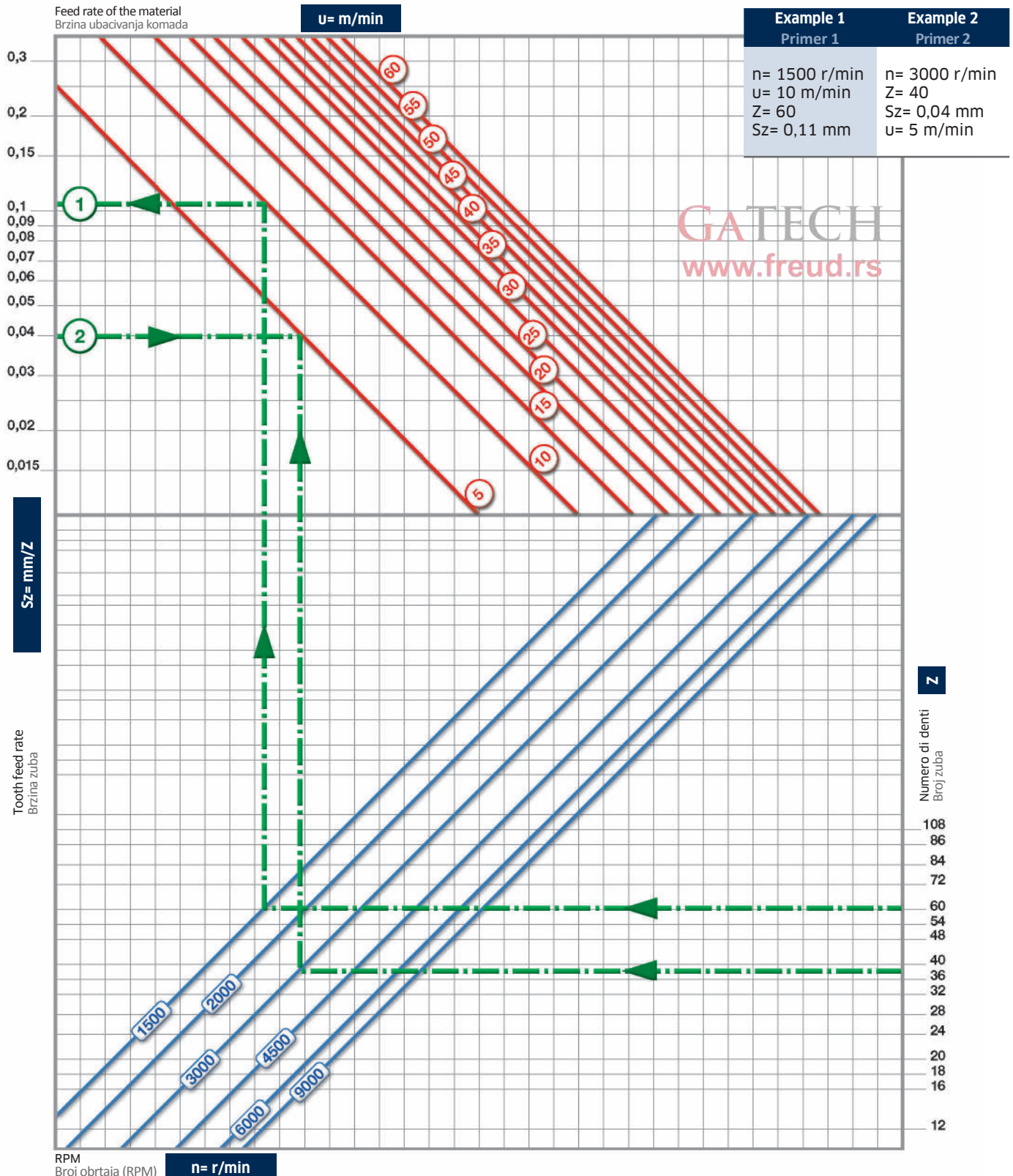

GATECH  
www.freud.rs

# Explanation of symbols and abbreviations Pojašnjenje simbola i skraćenica

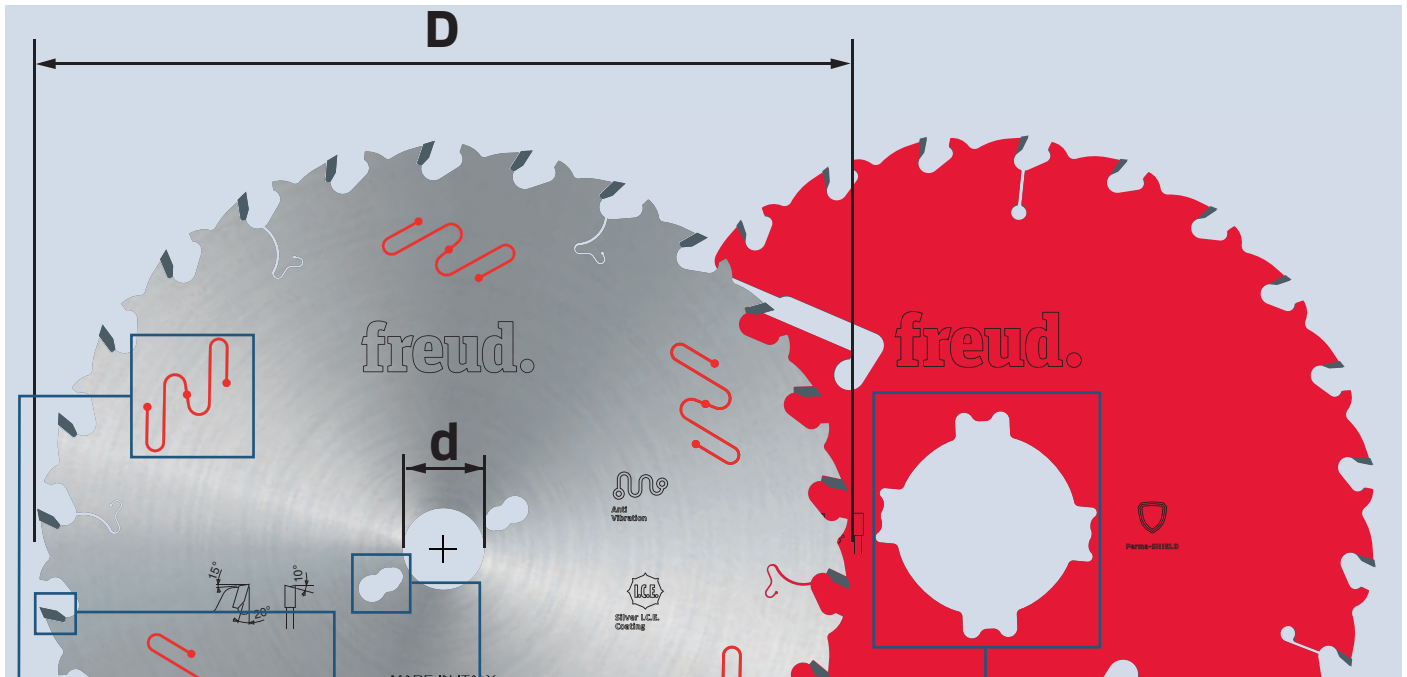

	D mm	B mm	b mm	d mm	Z	NL FT	KN CH	Code Codice	SAP SAP
	250	3,2	2,2	30	22	FT01		ABCD 1234	A00BC01234
	250	3,2	2,2	70	22	4CH 21x5		ABCD 1234	A00BC01234
	300	3,2	2,2	30	26	FT01		ABCD 1234	A00BC01234

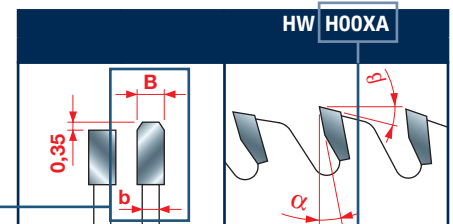

MICRO-GRAIN CARBIDE (HW) HARDNESS USED FOR MANUFACTURING TIPS  
TVRDOĆA MIKRO-ZRNA KARBIDA (HW) KORIŠĆENOG ZA PROIZVODNJU ZUBA

Tooth features - Karakteristike zuba

← INCREASING IMPACT STRENGTH • VEĆA ELASTIČNOST
INCREASING HARDNESS • VEĆA TVRDOĆA →

TF30	K10S	H01K	H00K	H00XA	H00XF
1515 9,8 11,75	1620 8,94 14,35	1870 8,22 14,36	1930 7,68 14,71	2070 7,71 14,73	2200 7,73 14,63

Vickers hardness • Tvrdća (HV10)

Transverse rupture • Tenzija (K1c)

Density • Gustina (gr/cm<sup>3</sup>)

**TiCo Carbide**

# Explanation of symbols and abbreviations

## Pojašnjenje simbola i skraćenica

GATECH  
www.freud.rs



PERFORMANCE		
Ultimate Najbolja	High Odlična	Standard Dobra
●		

CHART ABOUT THE SAW BLADE'S PERFORMANCE  
TABELA PERFORMANSI TESTERA

### SYMBOLS TO READ THE PRODUCT TABLES SIMBOLI POTREBNI ZA TUMAČENJE TABELA PROIZVODA

<b>D</b>	Diameter Prečnik	<b>d</b>	Central bore Centralni otvor	<b>α</b>	Hook angle Grudni ugao
<b>B</b>	Cutting thickness Debljina reza	<b>Z</b>	Number of teeth Broj zuba	<b>B B</b>	Back relief angle Ledni ugao
<b>B-B1</b>	Adjustable cutting thickness Podesiva debljina reza	<b>KN CH</b>	Keyways Otvori za klinove	<b>Code Codice</b>	Item code Šifra artikla
<b>b</b>	Saw blade body thickness Debljina tela testere	<b>NL FT</b>	Pin holes Pomoćni otvori	<b>SAP SAP</b>	Item code - for SAP users only Šifra artikla - samo za klijente SAP

### OTHER SYMBOLS ALTRI SIMBOLI

	Silver I.C.E. Coating Silver I.C.E. zaštitni sloj		Multi-rip saw blade for ripping of softwood Testera za uzdužno rezanje mekog drveta na višelisnim cirkularima		Saw blade to cut solid wood and composites with nails and impurities Testera za rezanje masiva i kompozita sa ekserima i nečistoćama
	Perma-SHIELD coating Perma-SHIELD zaštitni sloj		Multi-rip saw blade for ripping of hardwood Testera za uzdužno rezanje tvrdog drveta na višelisnim cirkularima		Saw blade to cut laminates Testera za rezanje laminata
	Anti-vibration technology Antivibraciona tehnologija		Saw blade for ripping of softwood Testera za uzdužno rezanje mekog drveta		Saw blade to cut veneered Testera za rezanje furnira
	Saw blade for miter saws Testera za ger		Saw blade for ripping of hardwood Testera za uzdužno rezanje tvrdog drveta		Scoring saw blade Predrežac
	Saw blade for portable machines Testera za prenosne cirkulare		Saw blade for ripping of softwood Testera za uzdužno rezanje mekog drveta		Saw blade to cut picture frames Testera za rezanje ramova
	Right hand or left hand Desni ili levi smer kretanja		Saw blade for ripping of hardwood Testera za uzdužno rezanje tvrdog drveta		Saw blade to cut PVC Testera za rezanje PVC-a
	Tools for automatic feed Alati za automatsko dodavanje		Saw blade for cross cutting of softwood Testera za poprečno rezanje mekog drveta		Saw blade to cut plastic materials Testera za rezanje plastičnih materijala
	Disposable knives Izmenjive pločice (nožići)		Saw blade for cross cutting of hardwood Testera za poprečno rezanje tvrdog drveta		Saw blade to cut plexiglas Testera za rezanje plexiglasa
			Saw blade for ripping and cross cutting of softwood Testera za uzdužno i poprečno rezanje mekog drveta		Saw blade to cut solid surfaces Testera za rezanje radnih ploča
			Saw blade for ripping and cross cutting of hardwood Testera za uzdužno i poprečno rezanje mekog drveta		Saw blade to cut non-ferrous metals Testera za rezanje aluminijuma i obojenih metala
			Saw blade to cut wood composites Testera za rezanje drvenih kompozita		Saw blade to cut ferrous metals Testera za rezanje gvožđa i crnih metala

**freud.**

---

**freud S.p.A.**  
**Società Unipersonale**  
Via Padova, 3  
33010 Tavagnacco (UD) IT  
Tel. +39 0432 551411  
Fax +39 0432 551440  
info@freud.it  
www.freud.it

**GATECH D.O.O.**  
ALATI I MAŠINE ZA OBRADU DRVETA

---

Dučevac 15, 11260 Umka, Republika Srbija  
Tel: 011/802-70-70 Fax: 011/802-70-57  
www.gatech.rs info@gatech.rs

[www.freud.rs](http://www.freud.rs)